



SKYWORKS®

How to Solve Common Automotive Isolation Problems

skyworksinc.com



- Electric vehicle systems rely on isolation to safely connect low voltage and high voltage systems
- Automotive grade semiconductor devices improve system reliability
- Safety standards impact isolation devices in a vehicle
- Minor design improvements help solve common issues with digital isolators

The Need for Automotive Isolation

Inside every internal combustion vehicle is the tried and true 12 V electrical system. Inside every electric or hybrid electric vehicle (EV, HEV) is something much different. EVs and HEVs harness the power of high voltage electrical systems to efficiently drive the main electric motor(s), rapidly charge the battery, and quickly heat the cabin on cold days. EVs and HEVs today use 400 V or 800 V, with even higher voltages on the horizon. These high voltages require much more attention to electrical safety and the partitioning systems into low voltage and high voltage domains. Within a high voltage vehicle system, like the traction inverter, there may be multiple voltage domains that need to exchange information. These high voltage systems must also communicate with the central vehicle controller and with each other, all while keeping the driver and passengers safe from the high voltages. Galvanic isolation electrically separates the high and low voltage domains. In the past, optocouplers were used to pass information across the isolation barrier. However, advances in CMOS processes have opened the door to cutting edge, digital isolation. These new isolators provide the same or better levels of isolation and bring unprecedented integration to the humble isolator. EVs and HEVs have been quick to adopt this new technology to reduce size, increase efficiency, and improve reliability. Nonetheless, adopting digital isolation brings new challenges, many of which can be solved with some clever insights and simple design improvements.

The Difference Automotive Grade Isolation Makes

Semiconductor devices are widely marketed to the automotive industry, but many do not meet all the needs of an automotive system. The harsh environments and long life of a vehicle require automotive grade devices. Many industrial grade devices, including Skyworks' industrial isolation products, include an AEC-Q100 qualification. However, AEC-Q100 qualification alone does not make a device automotive grade. This is especially true of isolation devices, as they are a critical component from both a safety and system operation perspective. Isolators often relay control signals, measure key voltages and currents, and safely communicate with the main vehicle control unit. To truly meet the needs of an automotive system, the isolation devices must be automotive grade. As shown in Table 1, Skyworks' automotive grade isolation products go well beyond AEC-Q100 qualification. Dedicated automotive manufacturing processes and production test methodologies ensure quality and reliability. Detailed product information reports, including PPAP and IMDS documents, simplify designing a Skyworks' automotive isolator into the vehicle. Finally, all Skyworks' automotive grade devices include priority failure analysis with detailed 8D reports to quickly root cause any issues. True automotive grade goes beyond just an AEC-Q100 qualification and makes Skyworks' automotive isolation devices ready for the most demanding in-vehicle applications.

Industrial Grade (-I) vs Automotive Grade (-A) Comparison			
		Industrial Grade - Si8xxx-I	Automotive Grade - Si8xxx-A
Quality & Reliability	AEC-Q100 Qualification	See Datasheet	Yes
	ISO/TS16949 Audit Compliant	Yes	Yes
	VDA Audit Compliant	No	Yes
	Operating Temperature	Various	-40 to 125 °C
	DPPM	<50	Zero Defect Methodology
	Failure Analysis	Standard	Priority, 8D format
Foundry	Automotive Process Flow	No	Yes
	WAT SPL Monitoring	No	Yes
	Enhanced Bin Limits Set	No	Yes
Probe	Good Die Bad Cluster Detection	No	Yes
	Vbump Test	Yes	Yes
	Dynamic PAT	No	Yes
Assembly	Enhanced optical inspections	No	Yes
	Certified equipment and operators	No	Yes
Test	Room, Hot and Cold Test	100% ROOM or HOT with sampling of other temps	100% ROOM and HOT with COLD sampling
	Full Power Supply Range Testing	Yes	Yes
	Test coverage measured and documented to AEC-Q100	Yes	Yes
Test	Part Production Approval Process (PPAP)	No	Yes
	International Material Data System (IMDS)	No	Yes
	China Automotive Material Data System (CAMDS)	No	Yes

Table 1 – Comparison of Skyworks' automotive grade isolation products to industrial isolation products.

What is Galvanic Isolation?

The 12 V automotive systems of the past had little need for isolation, and to many in the automotive industry it is a new concept. Galvanic isolation separates two circuits with a high impedance barrier that prevents the flow of current between them. Isolation devices communicate information across the isolation barrier. For example, in a traction inverter the controller often exists in the low voltage domain, while the FETs driving the motor exist in the high voltage domain. An isolated gate driver allows the system controller to safely control the FETs from the low voltage domain. In addition, isolation provides critical safety to the system by protecting the low voltage circuits (and end users!) from the hazardous high voltages. Beyond safety, the isolation barrier reduces ground loops, and the associated noise, between two different circuits. This is especially useful in vehicle communication systems, where data integrity is key. With this basic understanding of galvanic isolation, some of the confusion behind safety certification requirements can also be resolved.

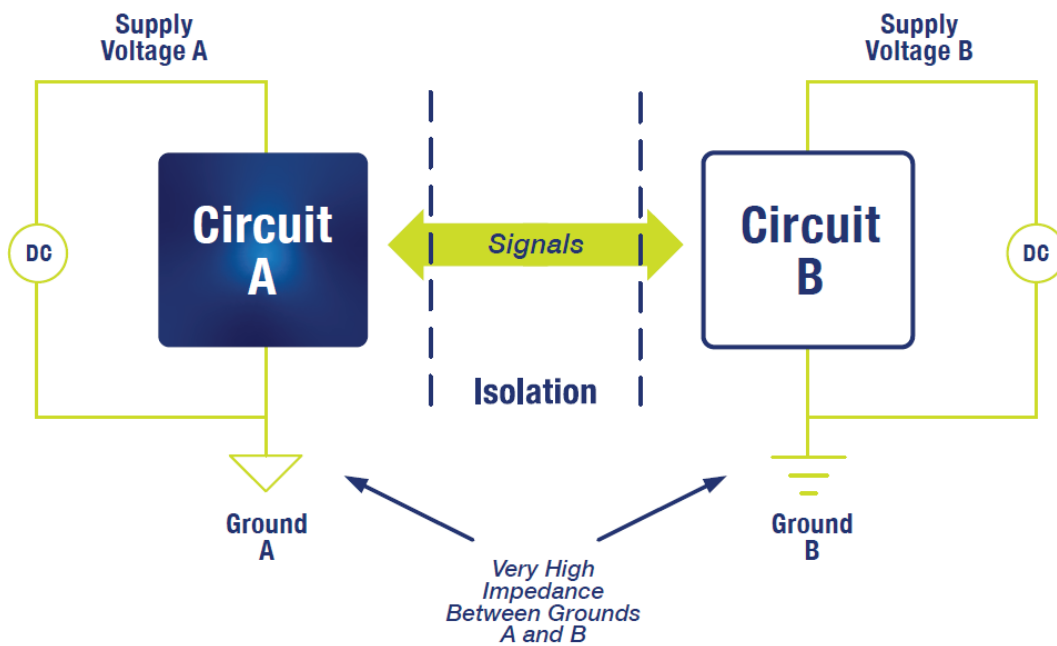
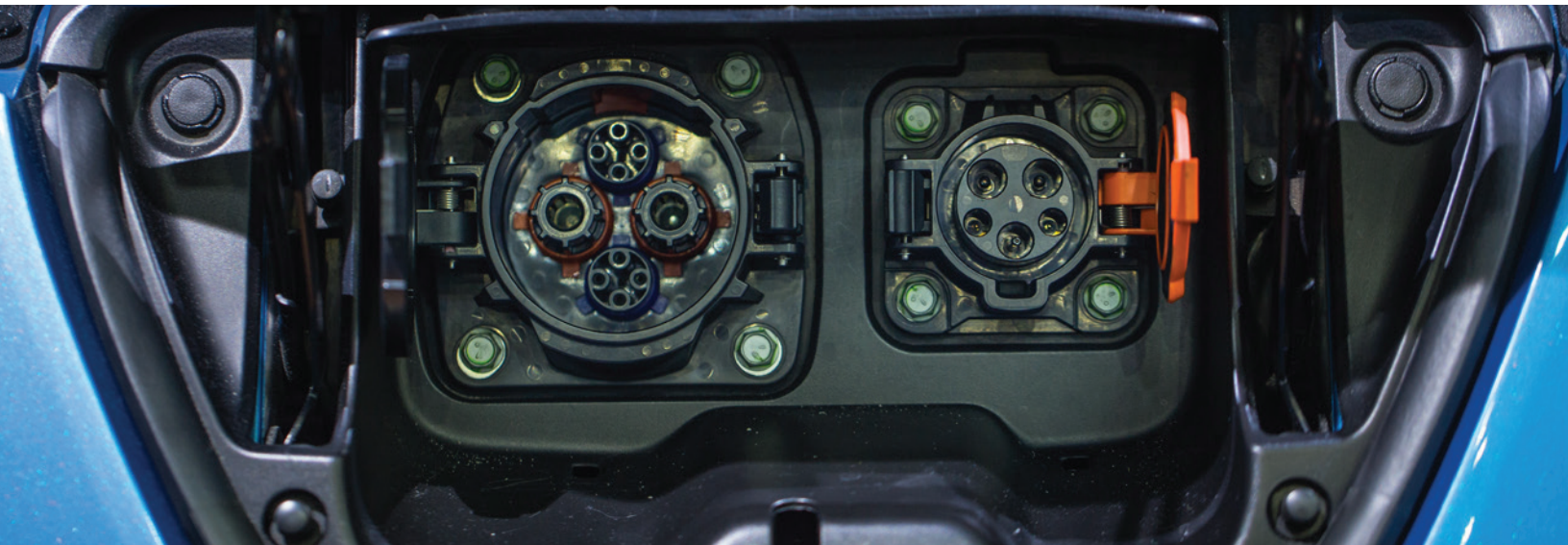

Figure 1 – Isolation creates a very high impedance between two grounds in a system, effectively eliminating the electrical connection between them.



Safety and Safety Certifications

With any high voltage system, it is absolutely essential that the designer consult with their internal safety team and/or external safety compliance agency to ensure that their system complies to its standard's safety requirements.

With the introduction of high voltage electrical systems, electrical safety has become a new challenge for automotive designers. Since isolators bridge the high voltage and low voltage domains, the safety features of an isolator are critical to system safety. Three common isolation safety topics include: creepage, clearance, and safety agency marks. Creepage and clearance rate the ability of the isolator's mechanical package design to prevent currents inadvertently flowing around the barrier contained within the isolation device. The safety agency marks help validate the ability of the isolation barrier within the device to prevent the flow of current through the isolation device.

Creepage and clearance are best understood through pictures, and Figure 2 illustrates the difference between the two. Creepage is the shortest distance around the package between two pins on either side of the isolation barrier. Clearance is the distance between two pins on the package representing the shortest line of sight distance (in air) between the two isolated sides. For a given high voltage, end system standards (e.g. IEC62368-1 for Information Technology) all have minimum creepage and clearance distance requirements and should be consulted before starting a design. Conformal coating is required if these distances cannot be met in air, which, among other issues, adds considerable cost and rework difficulties. Many older isolator packages have residual tie bars that are exposed on the edges and reduce the creepage rating of the package, as shown in Figure 3. Skyworks' new AS2 and AS3 wide body SOIC16 packages eliminate the external tie bars to provide 8 mm of creepage. With creepage and clearance requirements for the isolator met, the next step is to review the safety approvals of the isolation device.

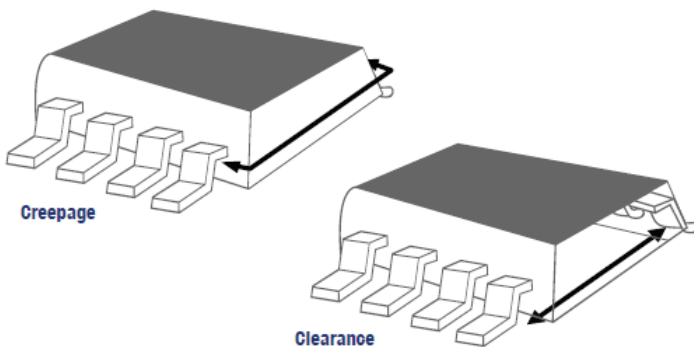

Figure 2 – Creepage and clearance graphically illustrated.

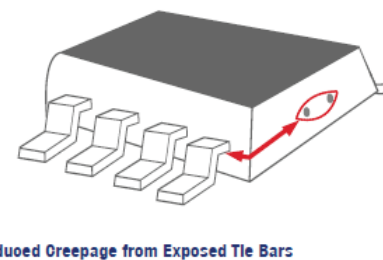

Figure 3 – Exposed tie bars (circled) reduce the amount of creepage.



Understanding how safety marks fit into the broader system certification, and what each mark means, takes some of the mystery out of the safety certification process. For automotive systems, typically what matters most are the safety agency marks on an isolator, such as VDE, UL, or CSA. These marks have a double meaning. First, a safety agency mark means the product has passed the testing requirements for that particular mark, with a test certificate and test report from the safety agency. Second, and this is often misunderstood, the safety agency mark indicates the manufacturer has passed ongoing audits from the safety agency. These audits ensure the tested and certified device is what the manufacturer is actually building. Without the audits, the manufacturer may change the device construction and violate the safety certification. Safety agencies will only provide their mark if both requirements have been met. Skyworks' isolation devices have a variety of safety marks, including UL, CSA, and VDE, with the safety certificates available from www.skyworksinc.com/Products/Isolation. Because isolation devices are typically considered safety critical by safety agencies, using isolation devices with the appropriate safety marks greatly simplifies certifying the entire system.

Common Failures and Solutions for Isolators in a Vehicle

Many designers are surprised to learn the isolation barrier in a digital isolator rarely fails. Rather, electrical overstress (EOS) is by far the most common reason an isolator fails in an automotive design. While there are a wide variety of problems that can cause EOS, two common issues are exceeding the power supply and I/O voltage ratings and damage from ESD events.

Like any semiconductor device, isolation devices specify absolute max values for power supply and input voltage ranges. If these values are exceeded, the device can quickly be damaged. Most digital isolation devices require power on both sides of the isolation barrier, VDDA and VDDB. Digital isolators, such as the [Si86xx](#) family, pass digital I/O signals across the isolation barrier. The supply voltages for each side of the isolator have an input range typical for a CMOS device and the I/O pins need to stay in the range of VDD. Some digital isolator devices, like the [Si88xx](#) family, have a built-in dc-dc controller to provide power to both sides of the device. Nonetheless, these devices typically still limit their I/O pins to CMOS voltage levels. In contrast, isolated gate drivers often offer a much wider VDD range on the side of the isolator driving the FET or IGBT power device, because many power devices need gate voltages higher than what typical CMOS can provide. Table 2 shows the differences between the supply and I/O voltages for [Si86xx digital isolators](#) and [Si823x isolated gate drivers](#). A simple fix to many EOS problems is to ensure the VDD and I/O limits are strictly adhered to. In addition, carefully following the manufacturer's recommendations for bypass capacitors and placing them as close as possible to the device solves many EOS issues.

Typical Digital Isolator (Si86xx shown)			
	SYMBOL	MIN	MAX
Supply Voltage VDD	VDD1, VDD2	-0.5	7 V
Voltage on any I/O Pin with respect to Ground	Ax, Bx	-0.5	VDD + 0.5 V

Typical Isolated Gate Driver (Si823x shown)			
	SYMBOL	MIN	MAX
Drive-side Supply Voltage VDD	VDDA, VDDB	-0.6	30 V
Voltage on any I/O Pin with respect to Ground	VOA, VOB	-0.5	VDD + 0.5 V

Table 2 – Digital isolator and isolated gate driver supply and I/O voltage ratings.

Another common cause for electrical overstress is an ESD event, and unfortunately these can be much more complex and difficult to trace down. However, understanding what the different ESD ratings for a device mean yields a good starting point. For automotive applications, this means reviewing the AEC-Q100 ESD tests and how they relate to the type of ESD the isolator will experience in the system. AEC-Q100-002 tests human body model (HBM) ESD and AEC-Q100-011 tests capacitive discharge model (CDM) ESD. An AEC-Q100 qualified device has passed both of these tests to the specified ESD voltage. As the name implies, HBM ESD tests how robust a device is to electrostatic charge from a person with a built-up charge (e.g. from shuffling feet across carpet) touching the device. Figure 4 shows the test setup. In contrast, under the CDM model the device has the charge and dissipates that charge through a single pin over a low impedance, metal to metal contact. Figure 5 shows the typical test setup for CDM. In automotive applications, the AEC standard tests CDM on each pin three times in the positive and three times in the negative direction. By understanding these two types of ESD ratings, a system designer can evaluate how a device will perform under their system ESD requirements.

System level ESD tests differ considerably from the device level tests and are done at much higher levels and are tested at multiple points on the system. This results in very different ESD paths to the pins of the isolation device. Two common isolator ESD failures have relatively simple solutions involving capacitors. If one side of the isolator is being damaged in testing, increasing the VDD bypass capacitor on the failing side of the isolator usually resolves the issue. If it does not, then adding ESD protection, such as an ESD diode, RC circuit, or ferrite bead may be required. Another common type of ESD failure is damage occurring across the isolation barrier, with damage to both sides of the isolator. Simply adding a capacitor across the isolation barrier, between the two ground planes, often solves the issue. Known as a “Y capacitor”, this capacitor must be rated for the same or greater isolation voltage as the isolator because it sits across the isolation barrier. Just like the isolation device, the Y capacitor also needs to be automotive grade. Unfortunately, the Y capacitor may allow a small increase in the amount of AC “leakage current” that flows between the isolated power domains. The value of the Y capacitor must be limited to ensure the AC leakage current requirements of the application are not violated. Finally, if a Y capacitor does not solve the issue, then an isolation device with a higher surge rating, such as the 10 kV rated [Si86xxT](#), is likely required.

High voltages in electric vehicles are here to stay and with them the need for isolation throughout the vehicle. The latest digital isolation devices offer unprecedented capabilities and reliability to enable the high voltage electrical systems found in modern EVs and HEVs. Adopting this new isolation technology gives designers unique advantages and at the same time presents new challenges. However, as electric vehicle systems become more complex, the need for sophisticated isolation devices to connect and control them will only increase. As the market for EVs and HEVs grows and competition in the industry expands, automotive designers will continue to rely on isolation devices to safely and reliably drive innovation in high voltage EV and HEV systems.

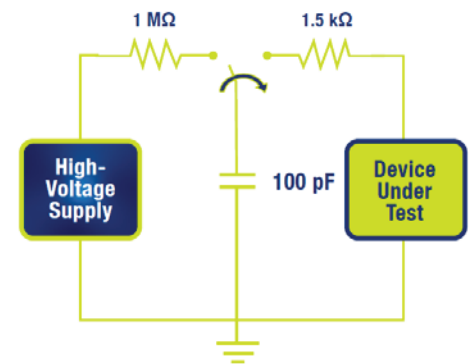

Figure 4 – Typical test setup for human body model ESD testing.

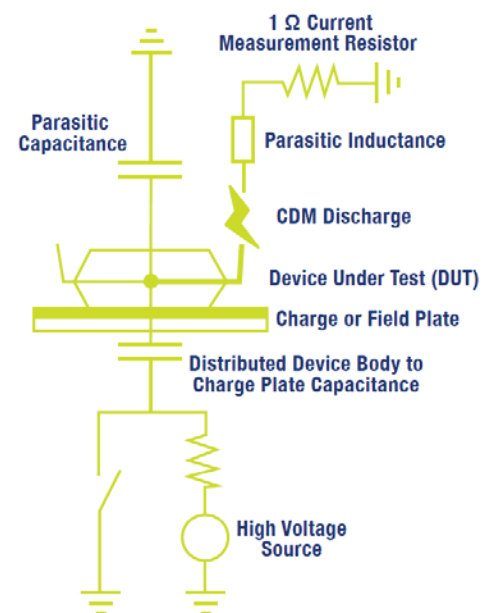

Figure 5 – Typical test setup for capacitive discharge model EST testing.

skyworksinc.com



SKYWORKS[®]

Copyright © 2017-2022 Skyworks Solutions, Inc. All Rights Reserved.

Skyworks, the Skyworks logo and others are trademarks or registered trademarks of Skyworks Solutions, Inc. or its subsidiaries in the United States and other countries. Third-party brands and names are for identification purposes only and are the property of their respective owners.