

PRODUCT SUMMARY

SKY77547 Tx–Rx iPAC™ Front-End Module – Quad-Band GSM/GPRS

Applications

- Quad-band cellular handsets encompassing
 - Class 4 GSM850/900
 - DCS1800/PCS1900
 - Class 12 GPRS multi-slot operation

Features

- High efficiency
 - 44% (GSM)
 - 42% (DCS/PCS)
- Low transmit supply current
 - 1.30 A (GSM)
 - 0.86 A (DCS/PCS)
- Internal ICC sense resistor for iPAC
- Closed loop iPAC
- 50 Ω matched Input/Output
- Tx–VCO-to-antenna and antenna-to-Rx-SAW filter RF interface
- Tx harmonics below –33 dBm
- PHEMT RF switch affords high linearity, low insertion loss, and less than 20 μA supply current in receive modes
- Small, low profile package
 - 8 mm x 6 mm x 1.05 mm
 - 30-pad configuration
- Compatible with multiple logic families
- Low APC current: 25 μA

NEW Skyworks Green™ products are RoHS (Restriction of Hazardous Substances)-compliant, conform to the EIA/EICTA/JEITA Joint Industry Guide (JIG) Level A guidelines, are halogen free according to IEC-61249-2-21, and contain < 1,000 ppm antimony trioxide in polymeric materials.

Description

The SKY77547 is a transmit and receive front-end module (FEM) with Integrated Power Amplifier Control (iPAC™) for quad-band cellular handsets comprising GSM850/900 and DCS1800/PCS1900 operation. Designed in a low profile, compact form factor, the SKY77547 offers a complete Transmit VCO-to-Antenna and Antenna-to-Receive SAW filter solution. The FEM also supports Class 12 General Packet Radio Service (GPRS) multi-slot operation.

The module consists of a GSM850/900 PA block and a DCS1800/PCS1900 PA block, impedance-matching circuitry for 50 Ω input and output impedances, Tx harmonics filtering, high linearity and a low insertion loss PHEMT RF switch, and a Power Amplifier Control (PAC) block with internal current sense resistor. A custom BiCMOS integrated circuit provides the internal PAC function and decoder circuitry to control the RF switches. The two Heterojunction Bipolar Transistor (HBT) PA blocks are fabricated onto a single Gallium Arsenide (GaAs) die. One PA block supports the GSM850/900 bands and the other PA block supports the DCS1800/PCS1900 bands. Both PA blocks share common power supply pads to distribute current. The output of each PA block and the outputs to the four receive pads are connected to the antenna pad through a PHEMT RF switch. The GaAs die, PHEMT die, Silicon (Si) die and passive components are mounted on a multi-layer laminate substrate. The assembly is encapsulated with plastic overmold.

Band selection and control of transmit and receive are performed using four external control pads. Refer to the block diagram in Figure 1 below. The band select pads, BS1 and BS2, select GSM850, GSM900, DCS, and PCS modes of operation. Transmit enable Tx_EN controls receive or transmit mode of the RF switch (Tx = logic 1). Proper timing between transmit enable Tx_EN and Analog Power Control VRAMP allows for high isolation between the antenna and Tx–VCO while the VCO is being tuned prior to the transmit burst.

The SKY77547 is compatible with logic levels from 1.2 V to VCC for BS1, BS2, and Tx_EN pads, depending on the level applied to the VLOGIC pad. This feature provides additional flexibility for the designer in the selection of FEM interface control logic.

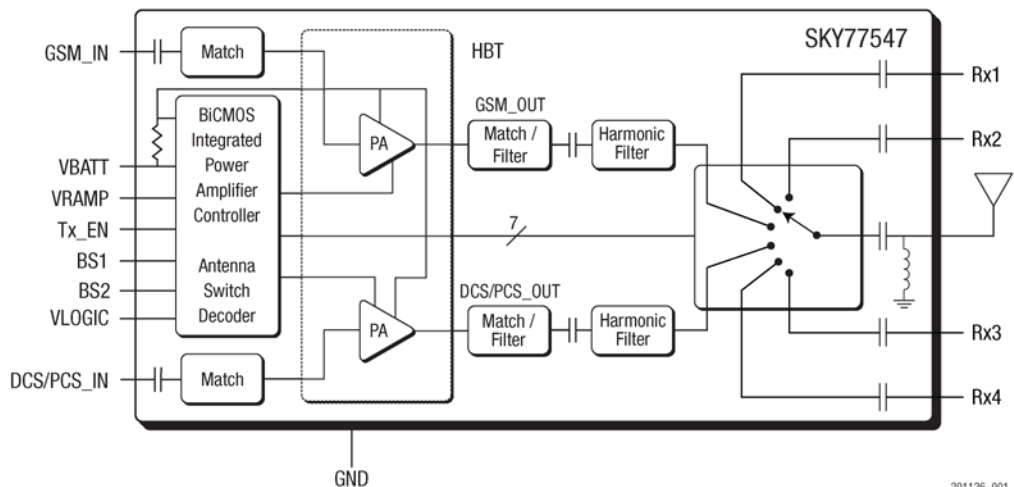

Figure 1. SKY77547 Functional Block Diagram

Revision History

Revision	Date	Description
A	February 18, 2009	Initial Release – Preliminary Information
B	October 17, 2017	This part is OBSOLETE. EOL #10066 CN 17363

OBSOLETE

©2009, 2017, Skyworks Solutions, Inc. All Rights Reserved

Information in this document is provided in connection with Skyworks Solutions, Inc. ("Skyworks") products or services. These materials, including the information contained herein, are provided by Skyworks as a service to its customers and may be used for informational purposes only by the customer. Skyworks assumes no responsibility for errors or omissions in these materials or the information contained herein. Skyworks may change its documentation, products, services, specifications or product descriptions at any time, without notice. Skyworks makes no commitment to update the materials or information and shall have no responsibility whatsoever for conflicts, incompatibilities, or other difficulties arising from any future changes.

No license, whether express, implied, by estoppel or otherwise, is granted to any intellectual property rights by this document. Skyworks assumes no liability for any materials, products or information provided hereunder, including the sale, distribution, reproduction or use of Skyworks products, information or materials, except as may be provided in Skyworks Terms and Conditions of Sale.

THE MATERIALS, PRODUCTS AND INFORMATION ARE PROVIDED "AS IS" WITHOUT WARRANTY OF ANY KIND, WHETHER EXPRESS, IMPLIED, STATUTORY, OR OTHERWISE, INCLUDING FITNESS FOR A PARTICULAR PURPOSE OR USE, MERCHANTABILITY, PERFORMANCE, QUALITY OR NON-INFRINGEMENT OF ANY INTELLECTUAL PROPERTY RIGHT; ALL SUCH WARRANTIES ARE HEREBY EXPRESSLY DISCLAIMED. SKYWORKS DOES NOT WARRANT THE ACCURACY OR COMPLETENESS OF THE INFORMATION, TEXT, GRAPHICS OR OTHER ITEMS CONTAINED WITHIN THESE MATERIALS. SKYWORKS SHALL NOT BE LIABLE FOR ANY DAMAGES, INCLUDING BUT NOT LIMITED TO ANY SPECIAL, INDIRECT, INCIDENTAL, STATUTORY, OR CONSEQUENTIAL DAMAGES, INCLUDING WITHOUT LIMITATION, LOST REVENUES OR LOST PROFITS THAT MAY RESULT FROM THE USE OF THE MATERIALS OR INFORMATION, WHETHER OR NOT THE RECIPIENT OF MATERIALS HAS BEEN ADVISED OF THE POSSIBILITY OF SUCH DAMAGE.

Skyworks products are not intended for use in medical, lifesaving or life-sustaining applications, or other equipment in which the failure of the Skyworks products could lead to personal injury, death, physical or environmental damage. Skyworks customers using or selling Skyworks products for use in such applications do so at their own risk and agree to fully indemnify Skyworks for any damages resulting from such improper use or sale.

Customers are responsible for their products and applications using Skyworks products, which may deviate from published specifications as a result of design defects, errors, or operation of products outside of published parameters or design specifications. Customers should include design and operating safeguards to minimize these and other risks. Skyworks assumes no liability for applications assistance, customer product design, or damage to any equipment resulting from the use of Skyworks products outside of stated published specifications or parameters.

Skyworks, the Skyworks symbol, "Breakthrough Simplicity," DCR, Helios, HIP3, Innovation to Go, Intera, iPAC, LIPA, Polar Loop, and System Smart are trademarks or registered trademarks of Skyworks Solutions, Inc., in the United States and other countries. Third-party brands and names are for identification purposes only, and are the property of their respective owners. Additional information, including relevant terms and conditions, posted at www.skyworksin.com, are incorporated by reference.