

**DATA SHEET**

# SMV1281-011LF: Hyperabrupt Junction Tuning Varactors

## Applications

- Wideband VCOs
- High-volume, low-cost systems

## Features

- High tuning ratio
- Packages rated MSL1, 260 °C per JEDEC J-STD-020
- For RoHS and other product compliance information, see the Skyworks Certificate of Conformance.



## Description

The SMV1281-011LF surface mount hyperabrupt junction varactor diodes are designed for very high capacitance tuning ratios with a low series resistance, which makes these devices especially attractive for wideband voltage controlled oscillator (VCO) applications. Table 1 describes the package and marking of the SMV1281-011LF varactor.

Table 1. Packaging and Marking

Single
SOD-323
<b>SMV1281-011LF</b> Marking: HP
$L_s = 1.5 \text{ nH}$

### Electrical Specifications

The absolute maximum ratings of the SMV1281-011LF varactors are provided in Table 2. Electrical specifications are provided in Table 3. Typical capacitance values are listed in Table 4. Typical capacitance vs reverse voltage performance for the SMV1281 varactors is illustrated in Figure 1.

The SPICE model is shown in Figure 2 and the associated model parameters are provided in Table 5.

Package dimensions are shown in Figures 3 and 5, and tape and reel drawings are provided in Figures 4 and 6.

### Package and Handling Information

Instructions on the shipping container label regarding exposure to moisture after the container seal is broken must be followed. Otherwise, problems related to moisture absorption may occur when the part is subjected to high temperature during solder assembly.

The SMV1281-011LF is rated to Moisture Sensitivity Level 1 (MSL1) at 260 °C. They can be used for lead or lead-free soldering. For additional information, refer to the Skyworks Application Note, *Solder Reflow Information*, document number 200164.

Care must be taken when attaching this product, whether it is done manually or in a production solder reflow environment. Production quantities of this product are shipped in a standard tape and reel format.

Table 2. Absolute Maximum Ratings

Parameter	Symbol	Minimum	Maximum	Units
Reverse voltage	V <sub>R</sub>		24	V
Forward current	I <sub>F</sub>		20	mA
Power dissipation	P <sub>DIS</sub>		250	mW
Operating temperature	T <sub>OP</sub>	-55	+125	°C
Storage temperature	T <sub>STG</sub>	-55	+150	°C
Electrostatic discharge:	ESD			
Charged Device Model (CDM), Class 4			2000	V
ESD Human Body Model (HBM), Class 3A			4000	V
Man-Machine (MM) Model, Class C			400	V

**Note:** Exposure to maximum rating conditions for extended periods may reduce device reliability. There is no damage to device with only one parameter set at the limit and all other parameters set at or below their nominal value. Exceeding any of the limits listed here may result in permanent damage to the device.

**ESD Handling:** Industry-standard ESD handling precautions must be adhered to at all times to prevent damage to this device.

Table 3. Electrical Specifications (Note 1)  
(T<sub>OP</sub> = 25 °C, Unless Otherwise Noted)

Parameter	Symbol	Test Condition	Min	Typical	Max	Units
Reverse current	I <sub>R</sub>	V <sub>R</sub> = 20 V			20	nA
Capacitance	C <sub>T</sub>	V <sub>R</sub> = 1 V	7.8	8.6	9.5	pF
		V <sub>R</sub> = 20 V	0.6	0.7	0.8	pF
Capacitance ratio	C <sub>TR</sub>	V <sub>R</sub> = 1 V/20 V		12		–
Resistance	R <sub>S</sub>	f = 500 MHz, V <sub>R</sub> = 1 V		1.7		Ω
Breakdown voltage	V <sub>BR</sub>	I <sub>R</sub> = 10 μA	24			V

**Note 1:** Performance is assured only under the conditions listed in this table.

**DATA SHEET • SMV1281-011LF VARACTOR**

Table 4. Capacitance vs Reverse Voltage

V <sub>R</sub> (V)	C <sub>T</sub> (pF)
0	13.30
1	8.60
2	6.30
3	4.80
4	3.60
5	2.70
6	2.00
7	1.60
8	1.40
9	1.20
10	1.10
11	1.00
12	0.94
13	0.89
14	0.85
15	0.81
16	0.78
17	0.75
18	0.73
19	0.71
20	0.69

Typical Performance Characteristics

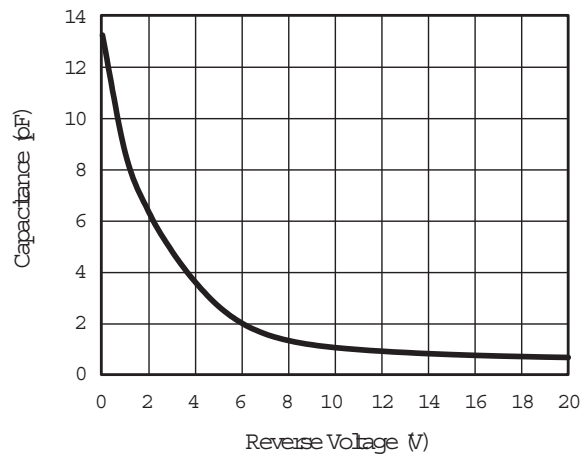

Figure 1. Capacitance vs Reverse Voltage

DATA SHEET • SMV1281-011LF VARACTOR

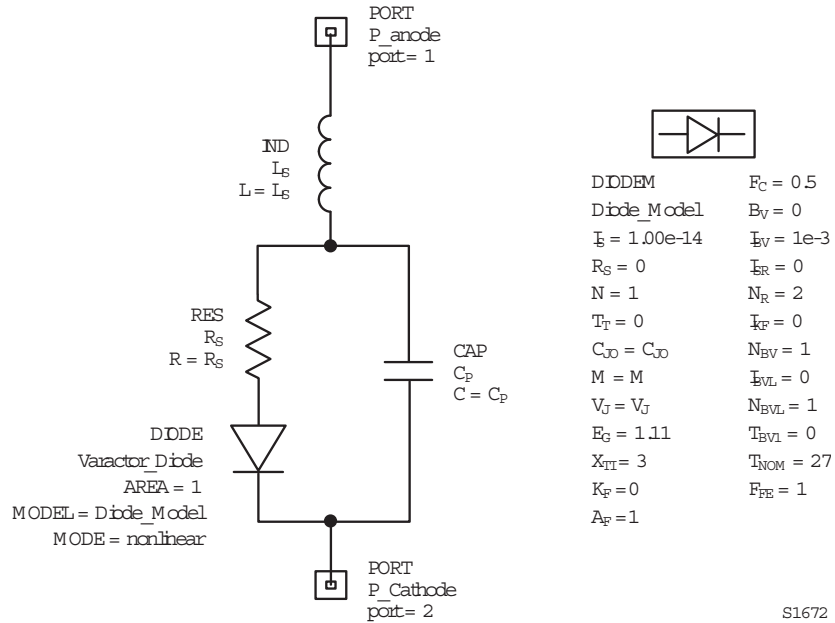
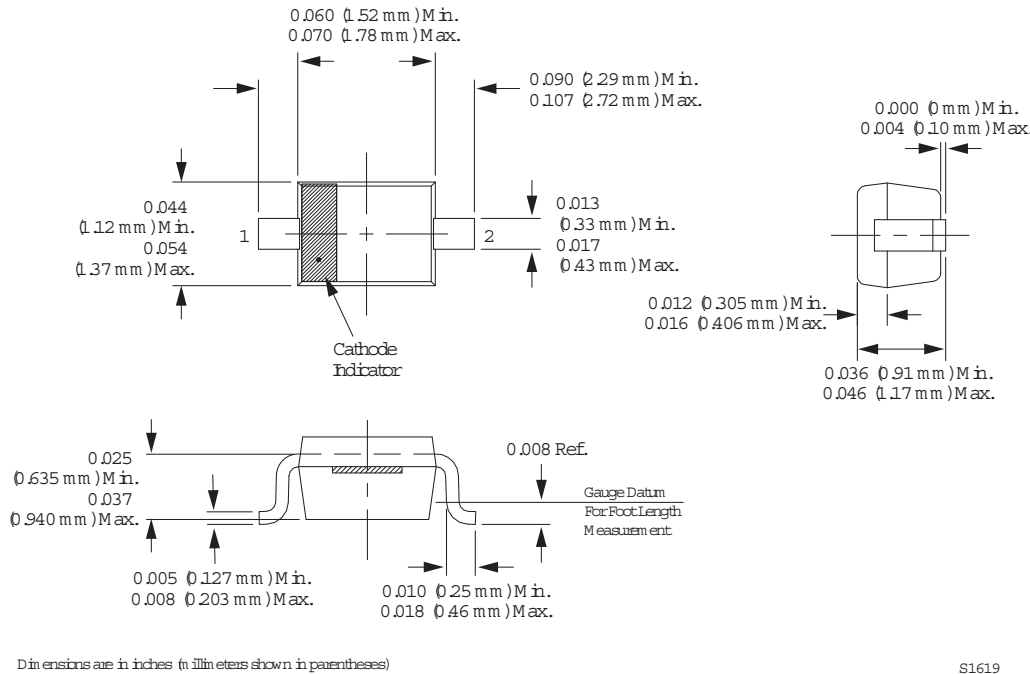

Figure 2. SPICE Model

Table 5. SPICE Model Parameters

Part Number	CJO (pF)	VJ (V)	M	CP (pF)	Rs (Ω)	Ls (nH)
SMV1281-011LF	13	14	6	0.62	1.7	1.2

**DATA SHEET • SMV1281-011LF VARACTOR**



**Figure 5. Package Dimensions**

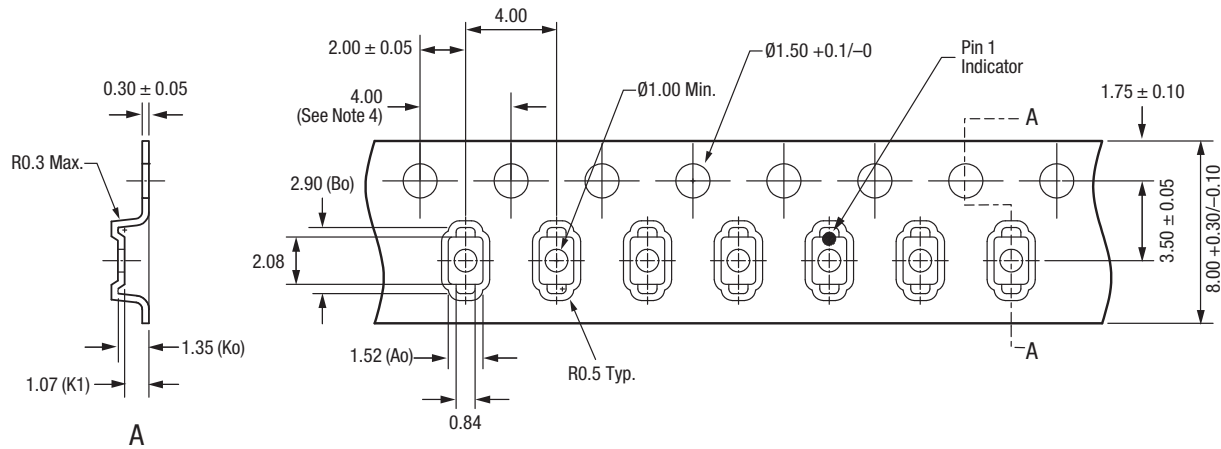

- Notes:**
1. Carrier tape: black conductive polystyrene.
  2. Cover tape: transparent conductive PSA.
  3. Cover tape size: 5.4 mm width.
  4. 10 sprocket hole pitch cumulative tolerance: ±0.20 mm.
  5. All measurements are in millimeters.

**S2910**

**Figure 6. Tape and Reel Information**

## DATA SHEET • SMV1281-011LF VARACTOR

Copyright © 2002-2007, 2009-2012, 2015, 2026, Skyworks Solutions, Inc. All Rights Reserved.

Information in this document is provided in connection with Skyworks Solutions, Inc., and its subsidiaries ("Skyworks") products or services. These materials, including the information contained herein, are provided by Skyworks as a service to its customers and may be used for informational purposes only by the customer. Skyworks assumes no responsibility for errors or omissions in these materials or the information contained herein. Skyworks may change its documentation, products, services, specifications or product descriptions at any time, without notice. Skyworks makes no commitment to update the materials or information and shall have no responsibility whatsoever for conflicts, incompatibilities, or other difficulties arising from any future changes.

No license, whether express, implied, by estoppel or otherwise, is granted to any intellectual property rights by this document. Skyworks assumes no liability for any materials, products or information provided hereunder, including the sale, distribution, reproduction or use of Skyworks products, information or materials, except as may be provided in Skyworks' Terms and Conditions of Sale.

THE INFORMATION IN THIS DOCUMENT AND THE MATERIALS AND PRODUCTS DESCRIBED THEREIN ARE PROVIDED "AS IS" WITHOUT WARRANTY OF ANY KIND, WHETHER EXPRESS, IMPLIED, STATUTORY, OR OTHERWISE, INCLUDING FITNESS FOR A PARTICULAR PURPOSE OR USE, MERCHANTABILITY, PERFORMANCE, QUALITY OR NON-INFRINGEMENT OF ANY INTELLECTUAL PROPERTY RIGHT; ALL SUCH WARRANTIES ARE HEREBY EXPRESSLY DISCLAIMED.

SKYWORKS DOES NOT WARRANT THE ACCURACY OR COMPLETENESS OF THE INFORMATION, TEXT, GRAPHICS OR OTHER ITEMS CONTAINED WITHIN THESE MATERIALS. SKYWORKS SHALL NOT BE LIABLE FOR ANY DAMAGES, INCLUDING BUT NOT LIMITED TO ANY SPECIAL, INDIRECT, INCIDENTAL, STATUTORY, OR CONSEQUENTIAL DAMAGES, INCLUDING WITHOUT LIMITATION, LOST REVENUES OR LOST PROFITS THAT MAY RESULT FROM THE USE OF THE MATERIALS OR INFORMATION, WHETHER OR NOT THE RECIPIENT OF MATERIALS HAS BEEN ADVISED OF THE POSSIBILITY OF SUCH DAMAGE.

Skyworks products are not designed, intended, authorized, or warranted for use or inclusion in life support or life endangering applications, devices, or systems where failure or inaccuracy might cause death or personal injury. Skyworks customers agree not to use or sell the Skyworks products for such applications, and further agree to, without limitation, fully defend, indemnify, and hold harmless Skyworks and its agents from and against any and all actions, suits, proceedings, costs, expenses, damages, and liabilities including attorneys' fees arising out of or in connection with such improper use or sale.

Skyworks assumes no liability for applications assistance, customer product design, or damage to any equipment resulting from the use of Skyworks products outside of Skyworks' published specifications or parameters. Customers are solely responsible for their products and applications using the Skyworks products.

"Skyworks" and the Skyworks Starburst logo are registered trademarks of Skyworks Solutions, Inc., in the United States and other countries. Third-party brands and names are for identification purposes only and are the property of their respective owners. Additional information, including relevant terms and conditions, posted at [www.skyworksinc.com](http://www.skyworksinc.com), are incorporated by reference.