

DATA SHEET

SKY12209-478LF: 0.9 to 4.0 GHz 40 W High Power Silicon PIN Diode SPDT Switch

Applications

- Transmit/receive switching and RF path switching in TD-SCDMA, WiMAX, and LTE base stations
- Transmit/receive and RF path switching in land mobile radios and military communication systems

Features

- High power handling: 40 W CW
- Low insertion loss: 0.3 dB typical
- High isolation: 42 dB @ 2.6 GHz
- Controlled with positive power supply
- Fast RF rise time: 40 ns typical
- Bias driver circuit available on request
- Small, QFN (16-pin, 4 x 4 mm) Pb-free package (MSL1, 260 °C per JEDEC J-STD-020)
- For RoHS and other product compliance information, see the [Skyworks Certificate of Conformance](#)

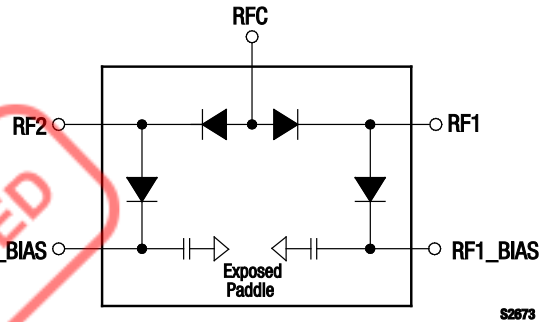
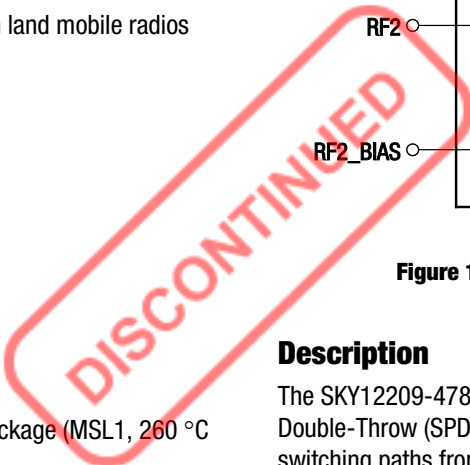

Figure 1. SKY12209-478LF Block Diagram

Description

The SKY12209-478LF is a high power handling, Single-Pole, Double-Throw (SPDT) silicon PIN diode switch with symmetrical switching paths from a single common port. The device operates over the 0.9 GHz to 4.0 GHz band. It features low insertion loss, excellent power handling, and superb linearity with low DC power consumption.

The SKY12209-478LF is well-suited for use as a high power transmit/receive and RF path switch in a variety of telecommunication systems such as WiMAX, TD-SCDMA, or LTE base stations.

The device is provided in a 4 x 4 mm, 16-pin Quad Flat No-Lead (QFN) package. A functional block diagram is shown in Figure 1. The pin configuration and package are shown in Figure 2. Signal pin assignments and functional pin descriptions are provided in Table 1.

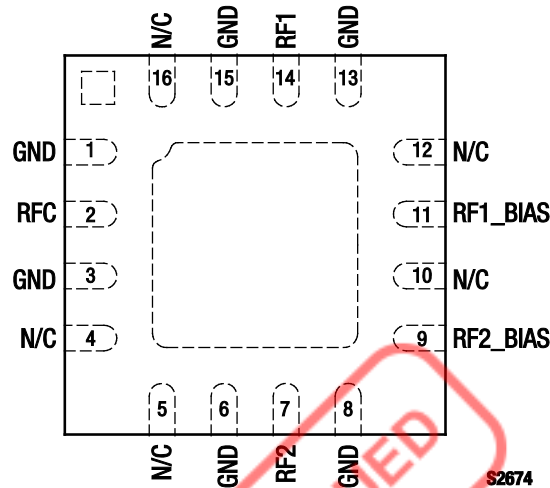

Figure 2. SKY12209-478LF Pinout – 16-Pin QFN (Top View)

Table 1. SKY12209-478LF Signal Descriptions

Pin	Name	Description	Pin	Name	Description
1	GND	Ground. Must be connected to ground using lowest possible impedance.	9	RF2_BIAS	RF ground port 2 and DC bias port
2	RFC	RF port and DC bias port	10	N/C	No connection
3	GND	Ground. Must be connected to ground using lowest possible impedance.	11	RF1_BIAS	RF ground port 1 and DC bias port
4	N/C	No connection	12	N/C	No connection
5	N/C	No connection	13	GND	Ground. Must be connected to ground using lowest possible impedance.
6	GND	Ground. Must be connected to ground using lowest possible impedance.	14	RF1	RF port 1 and DC bias port
7	RF2	RF port 2 and DC bias port	15	GND	Ground. Must be connected to ground using lowest possible impedance.
8	GND	Ground. Must be connected to ground using lowest possible impedance.	16	N/C	No connection

Electrical and Mechanical Specifications

The absolute maximum ratings of the SKY12209-478LF are provided in Table 2. Recommended operating conditions are specified in Table 3. Electrical specifications are provided in Table 4 (28 V bias voltage) and Table 5 (5 V bias voltage).

Typical performance characteristics of the SKY12209-478LF are illustrated in Figures 3 through 10.

The state of the SKY12209-478LF is determined by the logic provided in Table 6. Table 7 provides the logic for use with the SKY12209-478LF Evaluation Board.

Power derating data is plotted against temperature in Figures 11 and 12. Equivalent circuit diagrams for transmit and receive are shown in Figure 13.

Table 2. SKY12209-478LF Absolute Maximum Ratings

Parameter	Symbol	Minimum	Maximum	Units
RF CW input power ($T_{\text{SUBSTRATE}} = 25\text{ }^{\circ}\text{C}$)	P_{IN}		60	W
RF peak input power ($T_{\text{SUBSTRATE}} = 25\text{ }^{\circ}\text{C}$, RF burst width = 10 μs , RF burst repetition rate = 25 kHz)	P_{IN}		240	W
Control port reverse voltage	V_{CTL}		200	V
Control port forward current	I_{CTL}		200	mA
Operating temperature	T_{OP}	-55	+175	$^{\circ}\text{C}$
Storage temperature	T_{STG}	-55	+200	$^{\circ}\text{C}$
Electrostatic discharge:	ESD			
Charged Device Model (CDM), Class 4			1000	V
Human Body Model (HBM), Class 1C			1000	V
Machine Model (MM), Class B			200	V

Note: Exposure to maximum rating conditions for extended periods may reduce device reliability. There is no damage to device with only one parameter set at the limit and all other parameters set at or below their nominal value. Exceeding any of the limits listed here may result in permanent damage to the device.

CAUTION: Although this device is designed to be as robust as possible, Electrostatic Discharge (ESD) can damage this device. This device must be protected at all times from ESD. Static charges may easily produce potentials of several kilovolts on the human body or equipment, which can discharge without detection. Industry-standard ESD precautions should be used at all times.

Table 3. Recommended Operating Conditions

Parameter	Symbol	Min	Typical	Max	Units
Control port reverse voltage	V_{CTL}	5	28	100	V
Control port forward current (Note 1)	I_{CTL}	20	50	100	mA

Note 1: Per each diode in forward conduction mode.

Table 4. SKY12209-478LF Electrical Specifications, Bias Voltage = 28 V (Note 1)
(T_{OP} = +25 °C, Characteristic Impedance [Z₀] = 50 Ω, EVB Optimized for 0.9 to 4.0 GHz Operation, Unless Otherwise Noted)

Parameter	Symbol	Test Condition	Min	Typical	Max	Units
Insertion loss, RFC to RF1 and RF2 ports	IL _{RFC-RF1} IL _{RFC-RF2}	RFC port P _{IN} @ pin 2 = 0 dBm:				
		0.90 GHz		0.62		dB
		1.80 GHz		0.40		dB
		2.01 GHz		0.42		dB
		2.60 GHz		0.50	0.70	dB
3.50 GHz		0.65		dB		
Isolation, RF1 to RF2 ports	ISO _{RF1-RF2}	RF1 port P _{IN} @ pin 14 = 0 dBm:				
		0.90 GHz		35		dB
		1.80 GHz		37		dB
		2.01 GHz	40	39		dB
		2.60 GHz		46		dB
3.50 GHz		36		dB		
Isolation, RFC to RF1 and RF2 ports	ISO _{RFC-RF1} ISO _{RFC-RF2}	RFC port P _{IN} @ pin 2 = 0 dBm:				
		0.90 GHz		35		dB
		1.80 GHz		37		dB
		2.01 GHz	38	39		dB
		2.60 GHz		42		dB
3.50 GHz		36		dB		
Input return loss, RFC port	RL _{RFC}	RFC port P _{IN} @ pin 2 = 0 dBm:				
		0.90 GHz		13		
		1.80 GHz		28		dB
		2.01 GHz		25		dB
		2.60 GHz		22		dB
3.50 GHz		34		dB		
2 nd harmonic	2fo	RFC port P _{IN} @ pin 2 = +30 dBm:				
		0.90 GHz		-80		dBc
		1.80 GHz		-81		dBc
		2.01 GHz		-82		dBc
		2.60 GHz		-80		dBc
3.50 GHz		-81		dBc		
3 rd harmonic	3fo	RFC port P _{IN} @ pin 2 = +30 dBm:				
		0.90 GHz		-92		dBc
		1.80 GHz		-92		dBc
		2.01 GHz		-95		dBc
		2.60 GHz		-96		dBc
3.50 GHz		-93		dBc		
3 rd Order Input Intercept Point	IIP3	RFC port P _{IN} @ pin 2 = +30 dBm/tone, Δf = 1 MHz, @ 2.6 GHz		+76		dBm
Maximum CW input power	P _{IN_CW}	0.9 to 3.5 GHz		40		W
Transmit RF switching time	t _{sw}	10% to 90% RF rise time, repetition rate = 100 kHz, @ 2.6 GHz		40		ns
Thermal resistance (junction-to-case)	Θ _{JC}			64.2		°C/W

Note 1: Performance is guaranteed only under the conditions listed in this Table.

Table 5. SKY12209-478LF Electrical Specifications, Bias Voltage = 5 V (Note 1)
(T_{OP} = +25 °C, Characteristic Impedance [Z₀] = 50 Ω, EVB Optimized for 0.9 to 4.0 GHz Operation, Unless Otherwise Noted)

Parameter	Symbol	Test Condition	Min	Typical	Max	Units
Insertion loss, RFC to RF1 and RF2 ports	IL _{RFC-RF1} IL _{RFC-RF2}	RFC port P _{IN} @ pin 2 = 0 dBm:				
		0.90 GHz		0.63		dB
		1.80 GHz		0.43		dB
		2.01 GHz		0.46		dB
		2.60 GHz		0.54	0.70	dB
3.50 GHz		0.63		dB		
Isolation, RF1 to RF2 ports	ISO _{RF1-RF2}	RFC port P _{IN} @ pin 14 = 0 dBm:				
		0.90 GHz		34		dB
		1.80 GHz		37		dB
		2.01 GHz		38		dB
		2.60 GHz	40	46		dB
3.50 GHz		36		dB		
Isolation, RFC to RF2 and RF1 ports	ISO _{RFC-RF2} ISO _{RFC-RF1}	RFC port P _{IN} @ pin 2 = 0 dBm:				
		0.90 GHz		33		dB
		1.80 GHz		36		dB
		2.01 GHz		38		dB
		2.60 GHz	38	42		dB
3.50 GHz		34		dB		
Input return loss, RFC port	RL _{RFC}	RFC port P _{IN} @ pin 2 = 0 dBm:				
		0.90 GHz		12		
		1.80 GHz		28		dB
		2.01 GHz		26		dB
		2.60 GHz		25		dB
3.50 GHz		32		dB		
2nd harmonic	2fo	RFC port P _{IN} @ pin 2 = +30 dBm:				
		0.90 GHz		-40		dBc
		1.80 GHz		-51		dBc
		2.01 GHz		-51		dBc
		2.60 GHz		-51		dBc
3.50 GHz		-55		dBc		
3rd harmonic	3fo	RFC port P _{IN} @ pin 2 = +30 dBm:				
		0.90 GHz		-51		dBc
		1.80 GHz		-63		dBc
		2.01 GHz		-68		dBc
		2.60 GHz		-63		dBc
3.50 GHz		-63		dBc		
3rd Order Input Intercept Point	IIP3	RFC port P _{IN} @ pin 2 = +30 dBm/tone, Δf = 1 MHz, @ 2.6 GHz		+76		dBm
Maximum CW input power	P _{IN_CW}	0.9 to 3.5 GHz		15		W
Transmit RF switching time	t _{sw}	10% to 90% RF rise time, repetition rate = 100 kHz, @ 2.6 GHz		40		ns
Thermal resistance (junction-to-case)	Θ _{JC}			64.2		°C/W

Note 1: Performance is guaranteed only under the conditions listed in this Table.

Typical Performance Characteristics

($T_{OP} = +25\text{ }^{\circ}\text{C}$, Characteristic Impedance [Z_0] = 50 Ω , EVB Optimized for 0.9 to 4.0 GHz Operation, Unless Otherwise Noted)

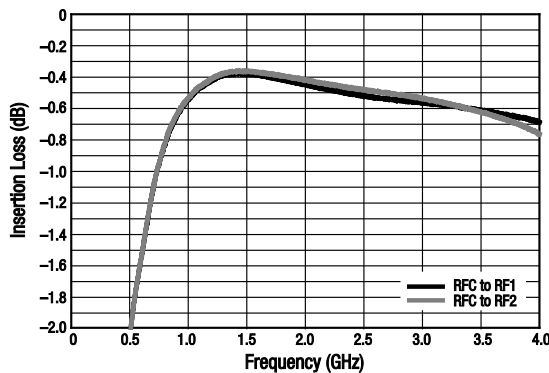

Figure 3. Insertion Loss vs Frequency
($V_{CTL} = 28\text{ V}$, $I_{CTL} = -50\text{ mA}$)

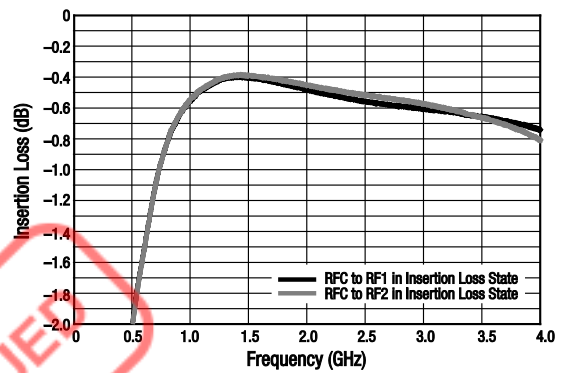

Figure 4. Insertion Loss vs Frequency
($V_{CTL} = 5\text{ V}$, $I_{CTL} = -50\text{ mA}$)

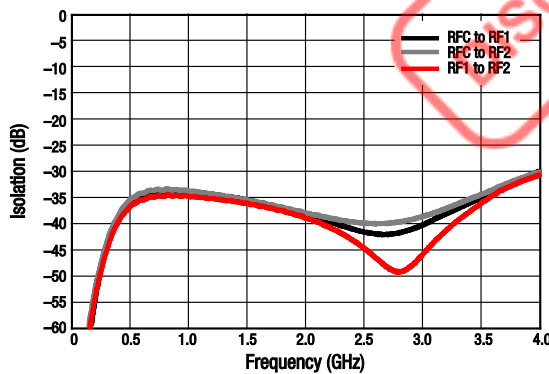

Figure 5. Isolation vs Frequency
($V_{CTL} = 28\text{ V}$, $I_{CTL} = -50\text{ mA}$)

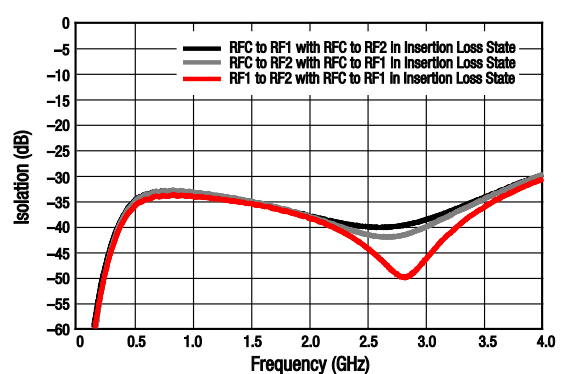

Figure 6. Isolation vs Frequency
($V_{CTL} = 5\text{ V}$, $I_{CTL} = -50\text{ mA}$)

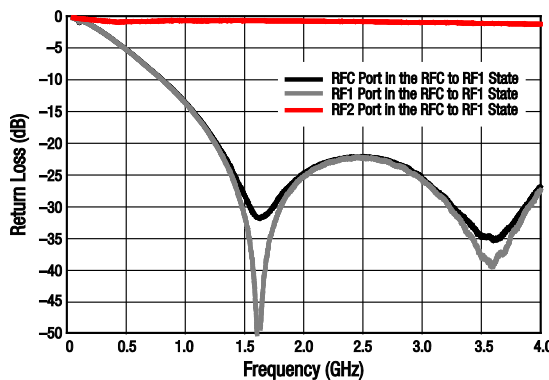

Figure 7. Return Loss vs Frequency
($V_{CTL} = 28\text{ V}$, $I_{CTL} = -50\text{ mA}$)

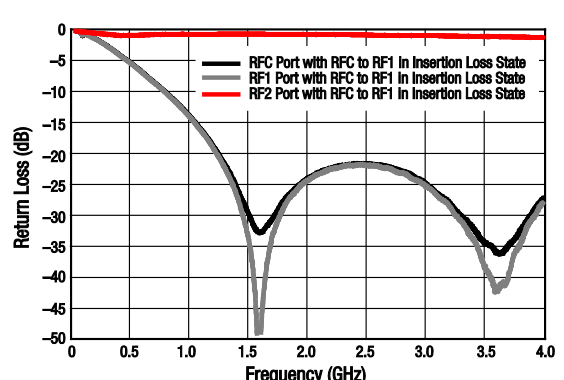

Figure 8. Return Loss vs Frequency
($V_{CTL} = 5\text{ V}$, $I_{CTL} = -50\text{ mA}$)

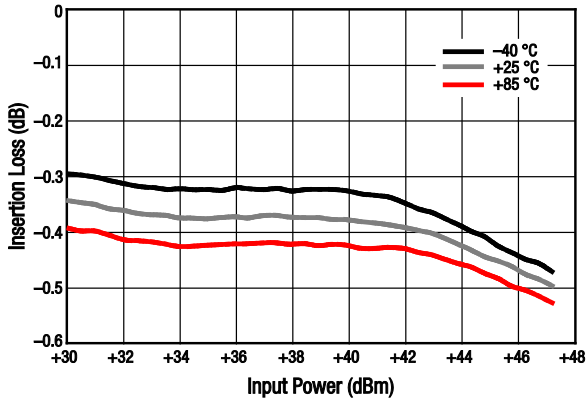

Figure 9. Insertion Loss vs CW Input Power
(f = 2.6 GHz, Evaluation Board Loss Included)

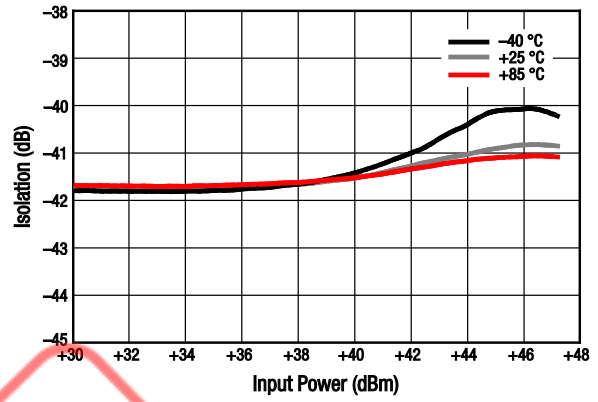

Figure 10. Isolation vs CW Input Power
(f = 2.6 GHz, Evaluation Board Loss Included)

Table 6. SKY12209-478LF Truth Table

Path		Control Conditions				
RFC-to-RF2 Port (Pin 2 to Pin 7)	RFC-to-RF1 Port (Pin 2 to Pin 14)	RFC Port Bias (Pin 2)	RF2 Port Bias (Pin 7)	RF1 Port Bias (Pin 14)	RF2_BIAS (Pin 9)	RF1_BIAS (Pin 11)
Low insertion loss	High isolation	1 V	-50 mA	28 V	28 V	-50 mA
High isolation	Low insertion loss	1 V	28 V	-50 mA	-50 mA	28 V

Table 7. SKY12209-478LF Evaluation Board Truth Table

Path		Control Conditions				
RFC-to-RF2 Port	RFC-to-RF1 Port	RFC Port Bias (V)	RF2 Port Bias (V)	RF1 Port Bias (V)	RF2_BIAS (V)	RF1_BIAS (V)
Low insertion loss	High isolation	5	0 (ground)	28	28	0 (ground)
High isolation	Low insertion loss	5	28	0 (ground)	0 (ground)	28

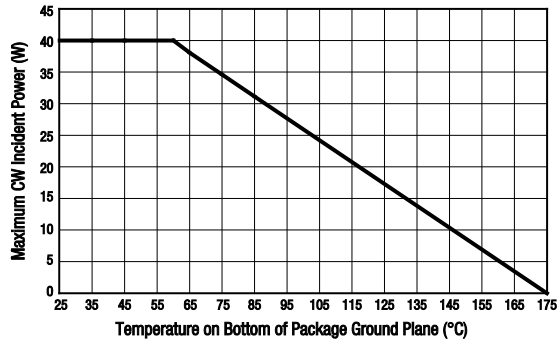

Figure 11. Power Derating, Maximum CW Incident Power (Insertion Loss = 0.2 dB) vs Temperature on Bottom of Package Ground Plane

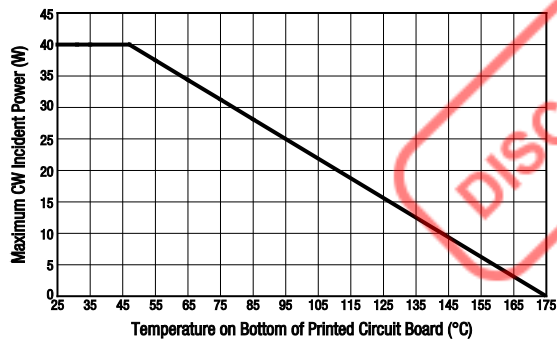

Figure 12. Power Derating, Maximum CW Incident Power (Insertion Loss = 0.2 dB) vs Temperature on Bottom of Printed Circuit Board

Evaluation Board Description

The SKY12209-478LF Evaluation Board is used to test the performance of the SKY12209-478LF PIN Diode SPDT switch. An assembly drawing for the Evaluation Board is shown in Figure 14. The layer detail is provided in Figure 15.

The SKY12209-478LF is designed to handle very large signals. Sufficient power may be dissipated by this switch to cause heating of the PIN diodes contained in the switch. It is very important to use a printed circuit board design that provides adequate cooling capability to keep the junction temperature of the PIN diodes below their maximum rated operating temperature.

As indicated in Figure 11, the x-axis temperature is referenced to the bottom of the QFN package. A printed circuit board with a very low thermal resistance and external heat sink design must be used to achieve the results shown in this Figure. The power derating curve with the x-axis temperature referenced to the bottom of the printed circuit board is provided in Figure 12.

The evaluation circuit is designed to facilitate control of the SKY12209-478LF SPDT switch with bias signals derived from positive voltages. The state of the PIN diodes within the

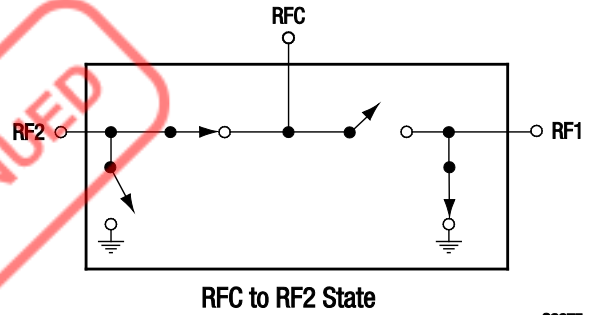
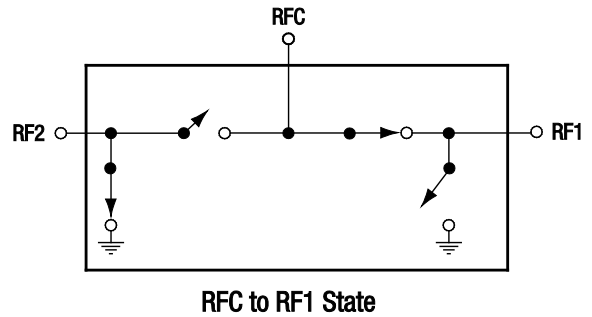

S2675

Figure 13. SKY12209-478LF Equivalent Circuit Diagrams

SKY12209-478LF is controlled with 5 V applied to the RFC port and bias voltages of either 28 V or 0 V applied to the remaining bias inputs (RF1 and RF2 ports). The switch state circuit diagrams are shown in Figure 13.

The values of resistors R2 and R3 (refer to the schematic diagram in Figure 16), which are both nominally 540 Ω, together with the magnitudes of the voltages applied to the RF1 and RF2 ports, determine which of the two series of diodes is biased into conduction and how much current flows through the forward biased diode.

For example, to place the SKY12209-478LF into the RFC to RF1 low insertion loss state, 0 V is applied to the RF1 port (which forward biases the diode between pins 2 and 14), 28 V is applied to the RF2 port (which reverse biases the diode between pins 2 and 7), 0 V is applied to the RF2_BIAS port (which applies a forward bias through R3 to the diode connected between pins 7 and 9), and 28 V is applied to the RF1_BIAS port (which applies a forward bias through R2 to the diode connected between pins 14 and 11).

The values of R2 and R3 may be adjusted to accommodate other bias voltages. Resistance values of 540 Ω are selected to

produce approximately 50 mA of forward bias current in the diodes, which are forced into conduction when the bias source voltage is 28 V.

The component values shown in the Evaluation Board circuit diagram (Figure 16) were selected to optimize performance in the 0.9 to 4.0 GHz band.

Refer to Table 8 for the Evaluation Board Bill of Materials. Table 9 provides voltage, current, and resistor values for bias adjustments.

Package Dimensions

The PCB layout footprint for the SKY12209-478LF is shown in Figure 17. Typical case markings are noted in Figure 18. Package dimensions for the 16-pin QFN are shown in Figure 19, and tape and reel dimensions are provided in Figure 20.

Package and Handling Information

Instructions on the shipping container label regarding exposure to moisture after the container seal is broken must be followed. Otherwise, problems related to moisture absorption may occur when the part is subjected to high temperature during solder assembly.

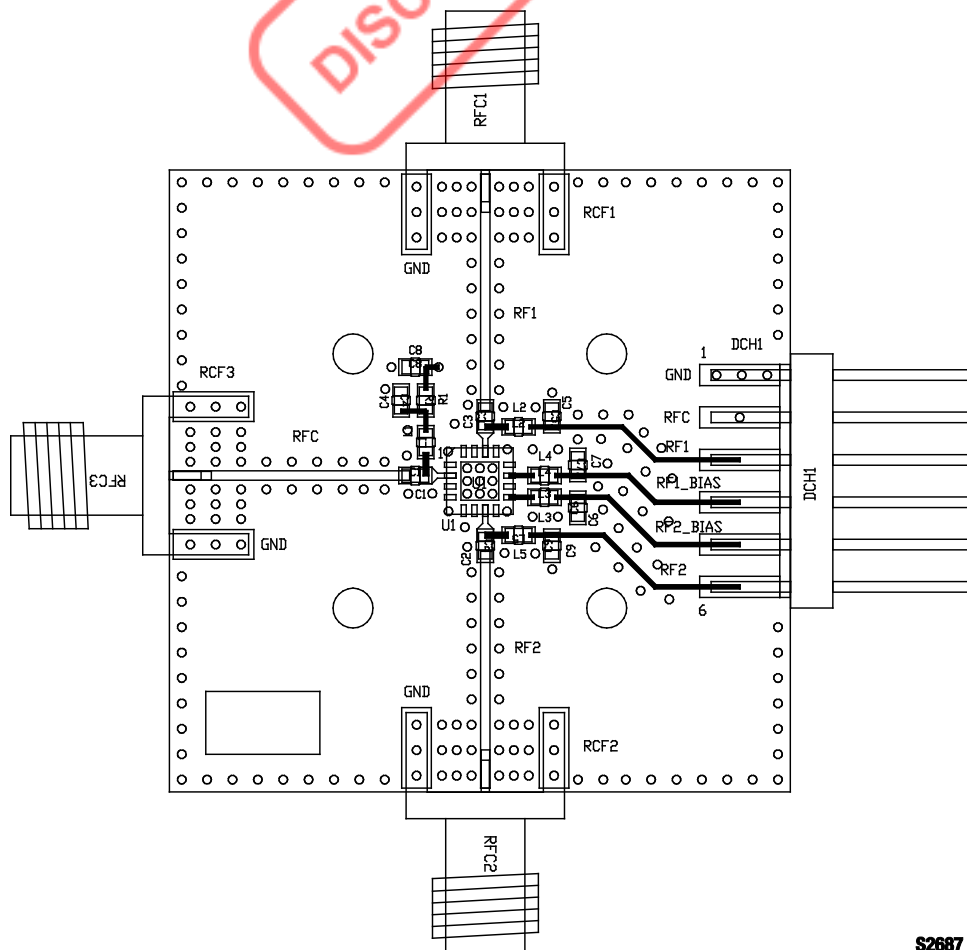

The SKY12209-478LF is rated to Moisture Sensitivity Level 1 (MSL1) at 260 °C. It can be used for lead or lead-free soldering. For additional information, refer to the Skyworks Application Note, *Solder Reflow Information*, document number 200164.

Care must be taken when attaching this product, whether it is done manually or in a production solder reflow environment. Production quantities of this product are shipped in a standard tape and reel format.

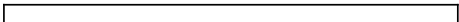
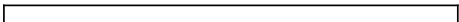
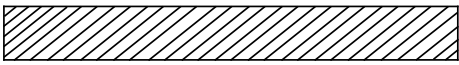
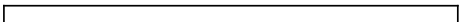
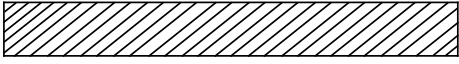
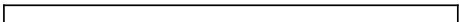
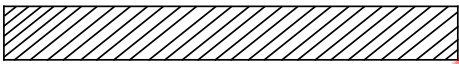
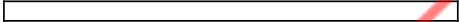

S2687

Figure 14. SKY12209-478LF Evaluation Board Assembly Diagram

Cross Section	Name	Thickness (in)	Material
	Top Soldermask		
	L1	(0.0028)	Cu foil
	Laminate	0.012 ± 0.0006	Rogers R04003C Core
	L2	(0.0014)	Cu foil
	Laminate	(Note 1)	FR4 Prepreg
	L3	(0.0014)	Cu foil
	Laminate	0.010 ± 0.0006	FR4 Core
	L4	(0.0028)	Cu foil
	Bottom Soldermask		

Note 1: Adjust this thickness to meet total thickness goal of 0.062 ± 0.005 inches.

S2531

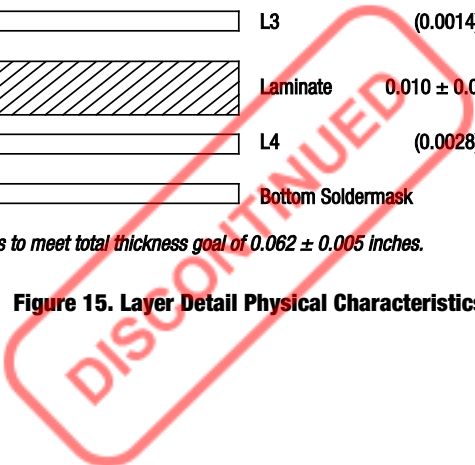
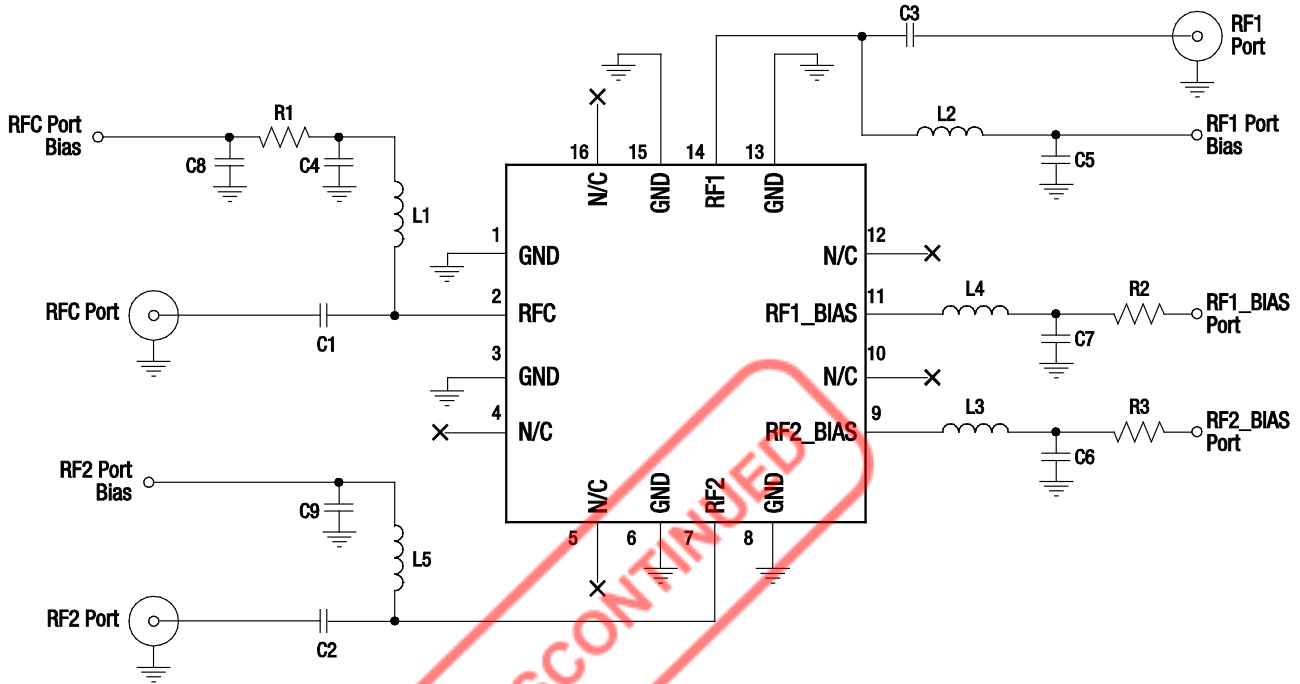

Figure 15. Layer Detail Physical Characteristics



NOTE: The N/C pins (4, 5, 10, 12, and 16) are not internally connected, so they can be left open or grounded.

S2676

Figure 16. Evaluation Board Schematic

Table 8. Evaluation Board Bill of Materials (Note 1)

Component	Value	Size	Manufacturer	Mfr Part Number	Characteristics
C1, C2, C3, C4, C5, C6, C7, C9	1000 pF	0603	TDK	C1608C0G1H102JT	COG, 50 V, ±5%
C8	1 μF	0603	TDK	C2012X7R1H104K	X7R, 50 V, ±10%
L1, L2, L3, L4, L5	22 nH	0603	Taiyo-Yuden	HK160822NJ-T	SRF, 1600 MHz, ±5%
R1 (Note 2)	80 Ω	0603	Panasonic	ERJ-3GEYJ161V	0.1 W, ±5%
R2, R3 (Note 3)	540 Ω	–	–	–	Axial leaded (off board)

Note 1: Component values selected are based on the desired frequency and bias level. Values may be adjusted for a specific response.

Note 2: Two 160 Ω resistors are combined in parallel to achieve a minimum power handling requirement and 80 Ω resistance.

Note 3: Evaluation Board does not include resistors R2 and R3. Operating at 28 V and 50 mA requires R2 and R3 resistors with a power dissipation greater than 1.35 W.

Table 9. Component Calculation Values

Vs (V)	V _{DIODE} (V)	V _{RES} (V)	Current (A)	Resistance (Ω)	Power Dissipation (W)
28	1	27	0.05	540	1.35
28	1	27	0.02	1350	0.54
5	1	4	0.05	80	0.20
5	1	4	0.02	200	0.08

Notes: Vs = supply voltage; V_{DIODE} = voltage drop across the diode; V_{RES} = voltage drop across the resistor.

R2 and R3 values are calculated by $(V_s - V_{DIODE})/I$, where I is the desired bias current.

The power dissipation in R2 and R3 is calculated by $I \times (V_s - V_{DIODE})$. The resistor selected must be safely rated with a power greater than the dissipated power.

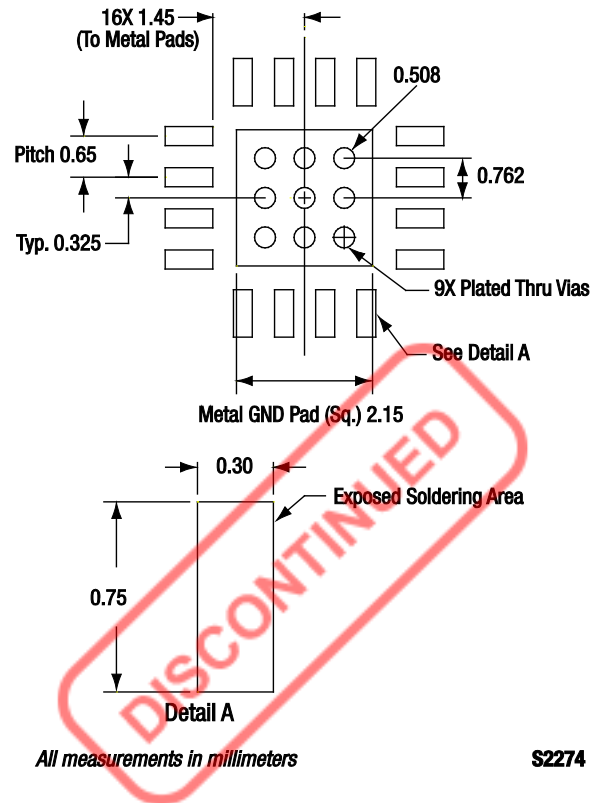

Figure 17. SKY12209-478LF PCB Layout Footprint

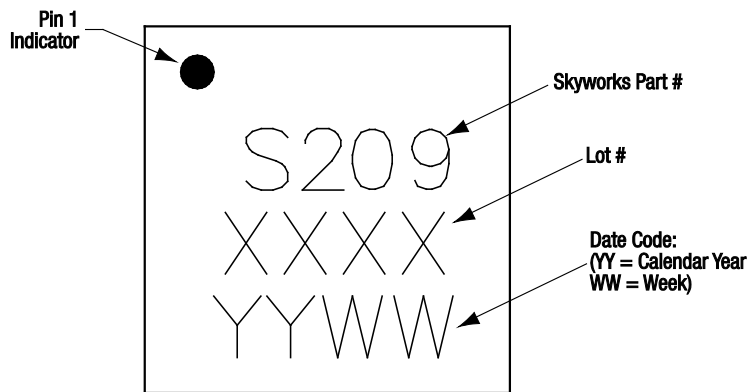
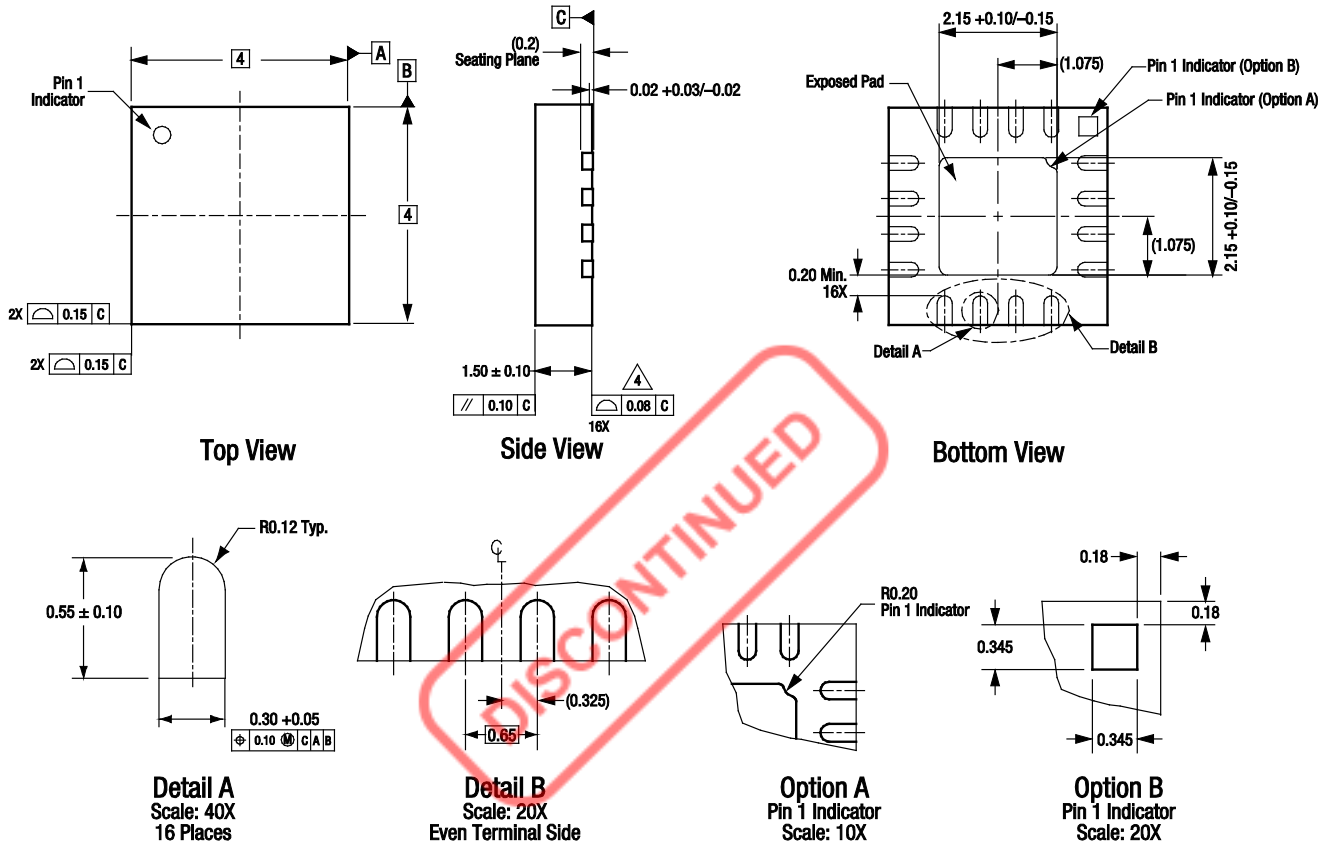

Figure 18. Typical Case Markings



All measurements are in millimeters.
 Dimensioning and tolerancing according to ASME Y14.5M-1994.
 Coplanarity applies to the exposed heat sink slug as well as the terminals.
 Package may have option A or option B pin 1 indicator.

S2400a

Figure 19. SKY12209-478LF 16-Pin QFN Package Dimensions

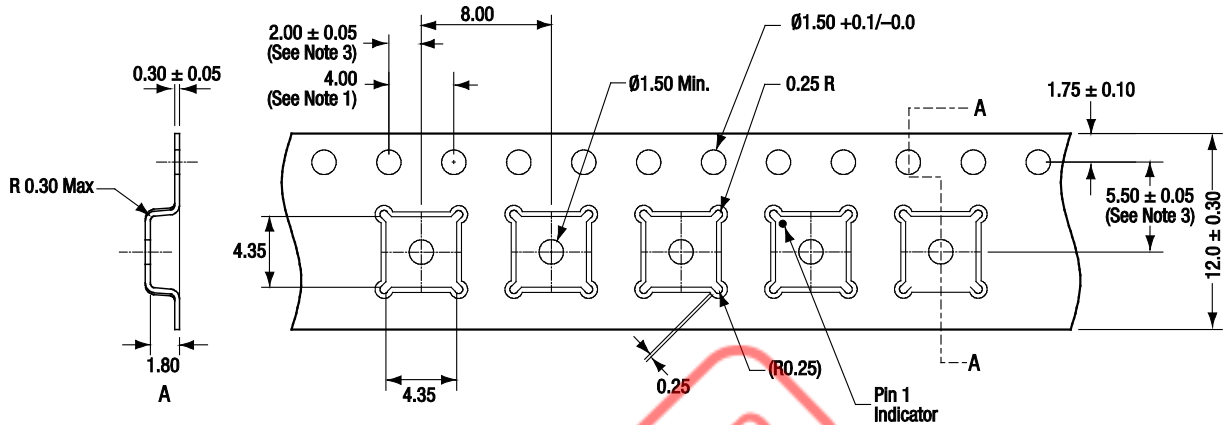

Notes:

1. Sprocket hole pitch cumulative tolerance: ± 0.2 mm
2. Carrier tape: black conductive polystyrene.
3. Pocket position relative to sprocket hole, measure as true position of pocket, not pocket hole.
4. Cover tape material: transparent conductive adhesive.
5. ESD surface resistivity must meet all ESD requirements of Skyworks, specified in GPO1-D232.
6. All dimensions are in millimeters.

S2817

Figure 20. SKY12209-478LF Tape and Reel Dimensions

Ordering Information

Model Name	Manufacturing Part Number	Evaluation Board Part Number
SKY12209-478LF PIN Diode SPDT Switch	SKY12209-478LF	SKY12209-478LF-EVB



Copyright © 2011-2014, 2026, Skyworks Solutions, Inc. All Rights Reserved.

Information in this document is provided in connection with Skyworks Solutions, Inc., and its subsidiaries (“Skyworks”) products or services. These materials, including the information contained herein, are provided by Skyworks as a service to its customers and may be used for informational purposes only by the customer. Skyworks assumes no responsibility for errors or omissions in these materials or the information contained herein. Skyworks may change its documentation, products, services, specifications or product descriptions at any time, without notice. Skyworks makes no commitment to update the materials or information and shall have no responsibility whatsoever for conflicts, incompatibilities, or other difficulties arising from any future changes.

No license, whether express, implied, by estoppel or otherwise, is granted to any intellectual property rights by this document. Skyworks assumes no liability for any materials, products or information provided hereunder, including the sale, distribution, reproduction or use of Skyworks products, information or materials, except as may be provided in Skyworks’ Terms and Conditions of Sale.

THE INFORMATION IN THIS DOCUMENT AND THE MATERIALS AND PRODUCTS DESCRIBED THEREIN ARE PROVIDED “AS IS” WITHOUT WARRANTY OF ANY KIND, WHETHER EXPRESS, IMPLIED, STATUTORY, OR OTHERWISE, INCLUDING FITNESS FOR A PARTICULAR PURPOSE OR USE, MERCHANTABILITY, PERFORMANCE, QUALITY OR NON-INFRINGEMENT OF ANY INTELLECTUAL PROPERTY RIGHT; ALL SUCH WARRANTIES ARE HEREBY EXPRESSLY DISCLAIMED. SKYWORKS DOES NOT WARRANT THE ACCURACY OR COMPLETENESS OF THE INFORMATION, TEXT, GRAPHICS OR OTHER ITEMS CONTAINED WITHIN THESE MATERIALS. SKYWORKS SHALL NOT BE LIABLE FOR ANY DAMAGES, INCLUDING BUT NOT LIMITED TO ANY SPECIAL, INDIRECT, INCIDENTAL, STATUTORY, OR CONSEQUENTIAL DAMAGES, INCLUDING WITHOUT LIMITATION, LOST REVENUES OR LOST PROFITS THAT MAY RESULT FROM THE USE OF THE MATERIALS OR INFORMATION, WHETHER OR NOT THE RECIPIENT OF MATERIALS HAS BEEN ADVISED OF THE POSSIBILITY OF SUCH DAMAGE.

Skyworks products are not designed, intended, authorized, or warranted for use or inclusion in life support or life endangering applications, devices, or systems where failure or inaccuracy might cause death or personal injury. Skyworks customers agree not to use or sell the Skyworks products for such applications, and further agree to, without limitation, fully defend, indemnify, and hold harmless Skyworks and its agents from and against any and all actions, suits, proceedings, costs, expenses, damages, and liabilities including attorneys’ fees arising out of or in connection with such improper use or sale.

Skyworks assumes no liability for applications assistance, customer product design, or damage to any equipment resulting from the use of Skyworks products outside of Skyworks’ published specifications or parameters. Customers are solely responsible for their products and applications using the Skyworks products.

“Skyworks” and the Skyworks Starburst logo are registered trademarks of Skyworks Solutions, Inc., in the United States and other countries. Third-party brands and names are for identification purposes only and are the property of their respective owners. Additional information, including relevant terms and conditions, posted at www.skyworksinc.com, are incorporated by reference.