

DATA SHEET

SMVA1470-004LF: Hyperabrupt Junction Tuning Varactor

Automotive Applications

- Low-noise VCOs and VCXOs in wireless systems
- Infotainment
- Navigation
- Telematics
- Garage door openers
- Wireless control systems

Features

- AEC-Q101 qualified
- High capacitance ratio
- SOT-23 package (MSL1, 260 °C per JEDEC J-STD-020)
- For RoHS and other product compliance information, see the [Skyworks Certificate of Conformance](#)

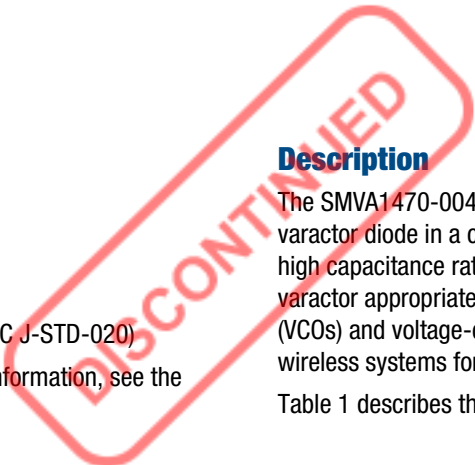

Description

The SMVA1470-004LF is a dual silicon, hyperabrupt junction varactor diode in a common cathode configuration. The specified high capacitance ratio and low series resistance make this varactor appropriate for low-noise voltage controlled oscillators (VCOs) and voltage-controlled crystal oscillators (VCXOs) in wireless systems for in-vehicle infotainment applications.

Table 1 describes the SMVA1470-004LF package and marking.

Table 1. Package and Marking

Common Cathode
SOT-23
SMVA1470-004LF Marking: ET3
$L_S = 1.4 \text{ nH}$

Electrical and Mechanical Specifications

The absolute maximum ratings of the SMVA1470-004LF varactor are provided in Table 2. Electrical specifications are provided in Table 3. Typical capacitance values are listed in Table 4.

Typical performance characteristics of the SMVA1470-004LF varactor are illustrated in Figures 1 and 2.

The SPICE model for the SMVA1470-004LF varactor is shown in Figure 3 and the associated model parameters are provided in Table 5.

Table 2. SMVA1470-004LF Absolute Maximum Ratings¹

Parameter	Symbol	Minimum	Maximum	Units
Forward current	I _F		20	mA
Power dissipation	P _D		250	mW
Storage temperature	T _{STG}	-55	+150	°C
Operating temperature	T _A	-55	+125	°C
Electrostatic discharge:	ESD			
Charged Device Model (CDM), Class 3			1000	V
Human Body Model (HBM), Class 1A			500	V
Machine Model (MM), Class A			50	V

¹ Exposure to maximum rating conditions for extended periods may reduce device reliability. There is no damage to device with only one parameter set at the limit and all other parameters set at or below their nominal value.

ESD HANDLING: Although this device is designed to be as robust as possible, electrostatic discharge (ESD) can damage this device. This device must be protected at all times from ESD when handling or transporting. Static charges may easily produce potentials of several kilovolts on the human body or equipment, which can discharge without detection. Industry-standard ESD handling precautions should be used at all times.

Table 3. SMVA1470-004LF Electrical Specifications¹
(T_A = +25 °C Unless Otherwise Noted)

Parameter	Symbol	Test Condition	Min	Typ	Max	Units
Reverse current	I _R	V _R = 10 V			20	nA
Capacitance	C _T	V _R = 1 V, F = 1 MHz	65.8	70.0	74.2	pF
		V _R = 4.5 V, F = 1 MHz	12.0	13.4	14.8	pF
Capacitance ratio	C _{TR}	C _T (1 V)/C _T (5 V)	5	6		–
Series resistance	R _S	V _R = 1.5 V, F = 900 MHz		0.5	0.8	Ω
Breakdown voltage	V _B	I _R = 10 μA	10			V

¹ Performance is guaranteed only under the conditions listed in this table.

Table 4. Capacitance vs Reverse Voltage

V_R (V)	C_T (pF)
0	113.9
0.5	87.4
1.0	71.3
1.5	59.3
2.0	49.0
2.5	39.1
3.0	29.4
3.5	21.4
4.0	16.3
4.5	13.3
5.0	11.5
5.5	10.3
6.0	9.5
6.5	8.9
7.0	8.5
7.5	8.1
8.0	7.9
8.5	7.7
9.0	7.6
9.5	7.5
10.0	7.5



Typical Performance Characteristics

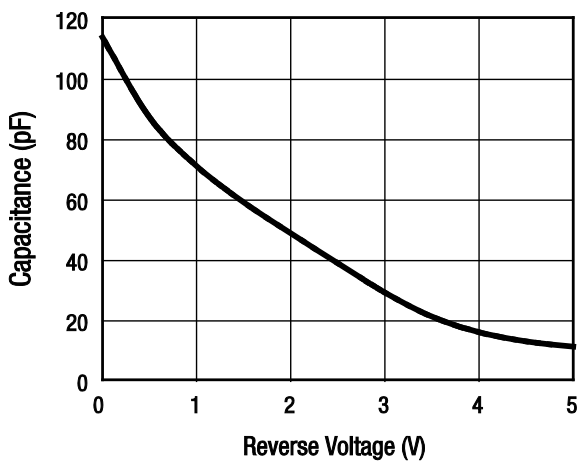

Figure 1. Capacitance vs Voltage

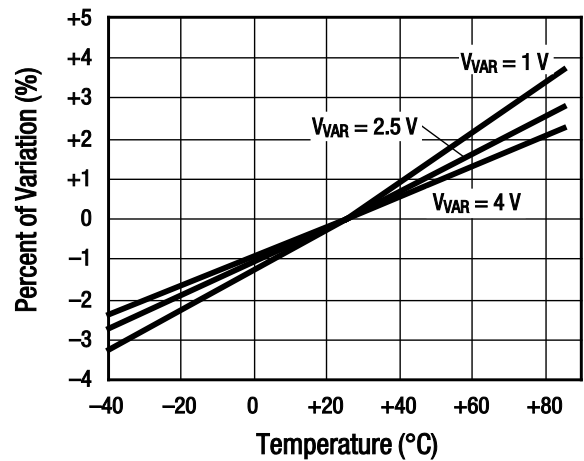

Figure 2. Relative Capacitance Change vs Temperature

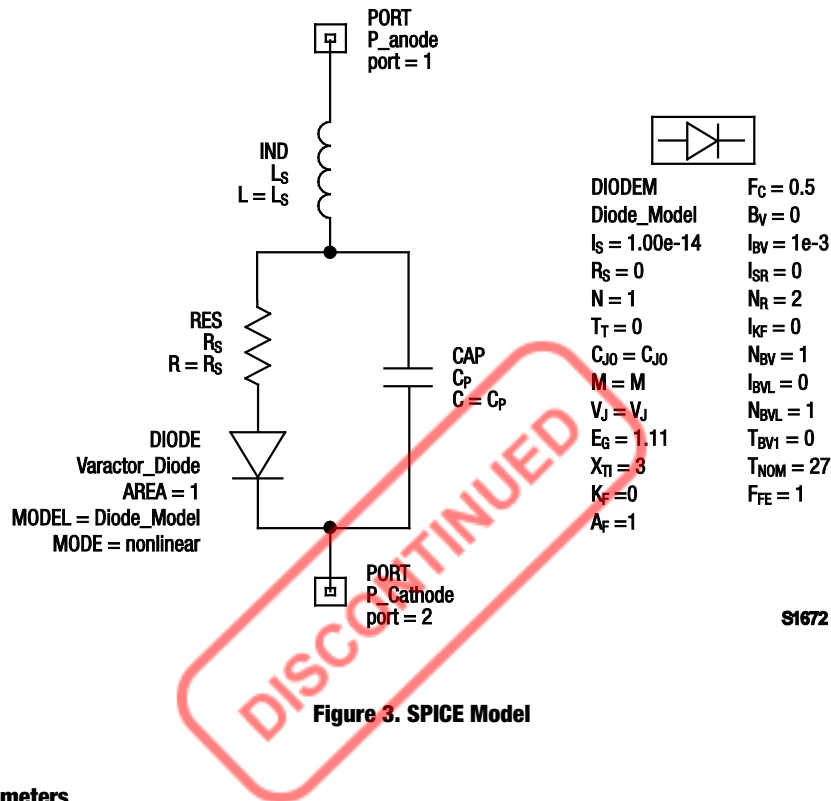

Table 5. SPICE Model Parameters

C _{J0} (pF)	V _J (V)	M	C _P (pF)	R _S (Ω)	L _S (nH)
110	80	39.7	3.94	0.5	1.4

Package Dimensions

Package dimensions are shown in Figure 4, and tape and reel dimensions are provided in Figure 5.

Package and Handling Information

Instructions on the shipping container label regarding exposure to moisture after the container seal is broken must be followed. Otherwise, problems related to moisture absorption may occur when the part is subjected to high temperature during solder assembly.

The SMVA1470-004LF varactor is rated to Moisture Sensitivity Level 1 (MSL1) at 260 °C. It can be used for lead or lead-free soldering. For additional information, refer to the Skyworks Application Note, *Solder Reflow Information*, document number 200164.

Care must be taken when attaching this product, whether it is done manually or in a production solder reflow environment. Production quantities of this product are shipped in a standard tape and reel format.



Copyright © 2002-2011, 2013-2015, 2018, 2026, Skyworks Solutions, Inc. All Rights Reserved.

Information in this document is provided in connection with Skyworks Solutions, Inc., and its subsidiaries ("Skyworks") products or services. These materials, including the information contained herein, are provided by Skyworks as a service to its customers and may be used for informational purposes only by the customer. Skyworks assumes no responsibility for errors or omissions in these materials or the information contained herein. Skyworks may change its documentation, products, services, specifications or product descriptions at any time, without notice. Skyworks makes no commitment to update the materials or information and shall have no responsibility whatsoever for conflicts, incompatibilities, or other difficulties arising from any future changes.

No license, whether express, implied, by estoppel or otherwise, is granted to any intellectual property rights by this document. Skyworks assumes no liability for any materials, products or information provided hereunder, including the sale, distribution, reproduction or use of Skyworks products, information or materials, except as may be provided in Skyworks' Terms and Conditions of Sale.

THE INFORMATION IN THIS DOCUMENT AND THE MATERIALS AND PRODUCTS DESCRIBED THEREIN ARE PROVIDED "AS IS" WITHOUT WARRANTY OF ANY KIND, WHETHER EXPRESS, IMPLIED, STATUTORY, OR OTHERWISE, INCLUDING FITNESS FOR A PARTICULAR PURPOSE OR USE, MERCHANTABILITY, PERFORMANCE, QUALITY OR NON-INFRINGEMENT OF ANY INTELLECTUAL PROPERTY RIGHT; ALL SUCH WARRANTIES ARE HEREBY EXPRESSLY DISCLAIMED. SKYWORKS DOES NOT WARRANT THE ACCURACY OR COMPLETENESS OF THE INFORMATION, TEXT, GRAPHICS OR OTHER ITEMS CONTAINED WITHIN THESE MATERIALS. SKYWORKS SHALL NOT BE LIABLE FOR ANY DAMAGES, INCLUDING BUT NOT LIMITED TO ANY SPECIAL, INDIRECT, INCIDENTAL, STATUTORY, OR CONSEQUENTIAL DAMAGES, INCLUDING WITHOUT LIMITATION, LOST REVENUES OR LOST PROFITS THAT MAY RESULT FROM THE USE OF THE MATERIALS OR INFORMATION, WHETHER OR NOT THE RECIPIENT OF MATERIALS HAS BEEN ADVISED OF THE POSSIBILITY OF SUCH DAMAGE.

Skyworks products are not designed, intended, authorized, or warranted for use or inclusion in life support or life endangering applications, devices, or systems where failure or inaccuracy might cause death or personal injury. Skyworks customers agree not to use or sell the Skyworks products for such applications, and further agree to, without limitation, fully defend, indemnify, and hold harmless Skyworks and its agents from and against any and all actions, suits, proceedings, costs, expenses, damages, and liabilities including attorneys' fees arising out of or in connection with such improper use or sale.

Skyworks assumes no liability for applications assistance, customer product design, or damage to any equipment resulting from the use of Skyworks products outside of Skyworks' published specifications or parameters. Customers are solely responsible for their products and applications using the Skyworks products.

"Skyworks" and the Skyworks Starburst logo are registered trademarks of Skyworks Solutions, Inc., in the United States and other countries. Third-party brands and names are for identification purposes only and are the property of their respective owners. Additional information, including relevant terms and conditions, posted at www.skyworksinc.com, are incorporated by reference.