

#### FEATURES

- Single Input, 5-way Output
- Wideband Operation: to Above 1 GHz
- Maintains RF signal path to high priority port (“Phone”) in power loss mode
- Used in conjunction with external FET for shutdown control
- 4.8 dB Typical Noise Figure at 4 dB Gain
- Single +3.3 V Supply
- High Linearity, Low Distortion
- Single-ended 75 Ohm Inputs/Outputs
- RoHS Compliant/Lead Free
- 4 x 4 x 0.9 mm 24-Lead QFN Package

#### APPLICATIONS

- Home gateways and CATV digital set-top boxes with multiple tuners, requiring phone bypass when power is lost

#### PRODUCT DESCRIPTION

The APS3625 active splitter accepts an RF input in the 50 MHz to 1.0 GHz frequency range and provides five RF outputs with minimal degradation in signal quality. The single-package surface mount device amplifies the input signals using highly linear, low noise amplification stages, and couples the amplified signal to five separate output paths to drive video tuner(s), a DOCSIS tuner(s), or other in-band inputs. The device provides one by-pass output to maintain a connection when the power is lost, which is intended

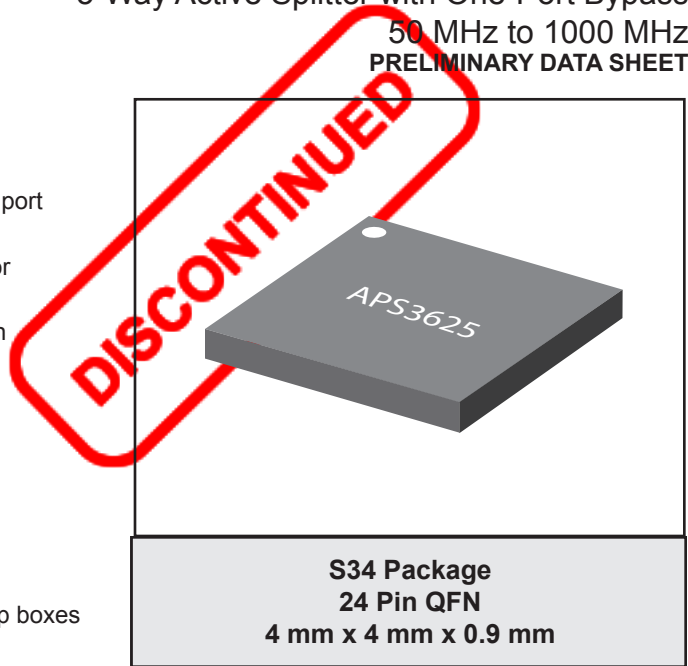

for critical signals such as a digital voice phone. The overall linearity of each tuner path is maintained across the entire operating frequency range, ensuring low distortion effects on each output signal.

Requiring a single +3.3 Volt supply, the active splitter design is implemented using the GaAs MESFET process. The small surface mount QFN packaging makes this device ideal for use in home gateways and multiple-tuner set-top boxes, supporting multiple video outputs, and/or DOCSIS 3.0 and IP phones.

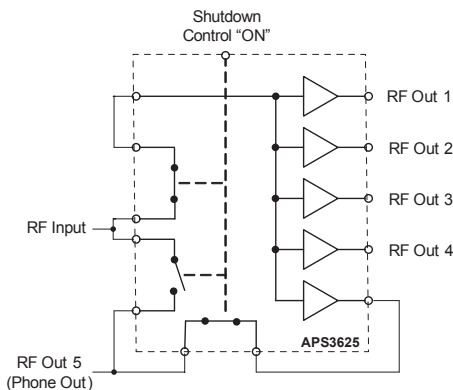

**Figure 1: Functional Block Diagram “ON” Mode**

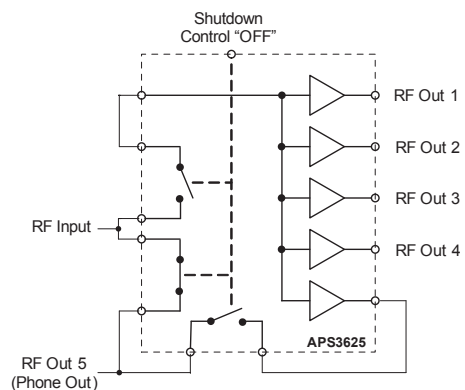

**Figure 2: Functional Block Diagram Bypass Mode**

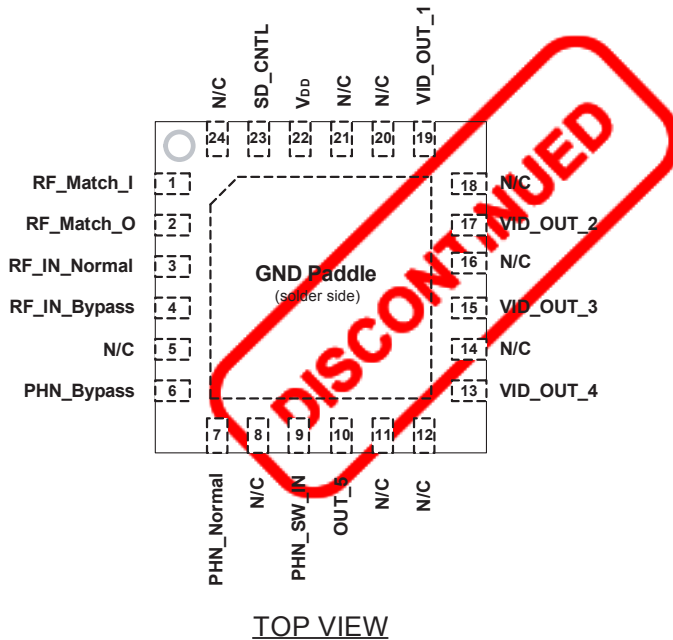

Figure 2: Pinout Diagram (X-ray Top View)

Table 1: Pin Description

PIN	NAME	DESCRIPTION	PIN	NAME	DESCRIPTION
1	RF_Match_I	Input from RF Match	24	N/C	No Connection
2	RF_Match_O	Output to RF Match	23	SD_CNTL	Control Input for Shut Down
3	RF_IN_Normal	RF Input - Normal Mode	22	V <sub>DD</sub>	V <sub>DD</sub>
4	RF_IN_Bypass	RF Input - Bypass Mode	21	N/C	No Connection
5	N/C	No Connection	20	N/C	No Connection
6	PHN_Bypass	"Phone" Output - Bypass Mode	19	VID_OUT_1	Video Output 1
7	PHN_Normal	"Phone Output - Normal Mode	18	N/C	No Connection
8	N/C	No Connection	17	VID_OUT_2	Video Output 2
9	PHN_SW_IN	Input to Phone Switch	16	N/C	No Connection
10	OUT_5	Output 5	15	VID_OUT_3	Video Output 3
11	N/C	No Connection	14	N/C	No Connection
12	N/C	No Connection	13	VID_OUT_4	Video Output 4

## ELECTRICAL CHARACTERISTICS

Table 2: Absolute Minimum and Maximum Ratings

PARAMETER	MIN	MAX	UNIT	COMMENTS
Supply Voltage ( $V_{CC}$ )	0	+8	V	
RF Input Power	-	+40	dBmV	per channel 132 channel loading
ESD Rating	500 1000	- -	V	Human Body Model, Class 1B Charged Device Model, Class 3
MSL Level	3-260	-		

Stresses in excess of the absolute ratings may cause permanent damage. Functional operation is not implied under these conditions. Exposure to absolute ratings for extended periods of time may adversely affect reliability.

Table 3: Operating Ranges

PARAMETER	MIN	TYP	MAX	UNIT	COMMENTS
Operating Frequency	50	-	1000	MHz	
Supply Voltage ( $V_{DD}$ )	-	+3.3	-	V	
RF Input Power ( $P_{IN}$ )	-15	-	+15	dBmV	
Case Temperature (Performance Spec Compliance)	-5	-	+100	°C	

The device may be operated safely over these conditions; however, parametric performance is guaranteed only over the conditions defined in the electrical specifications.

**Table 4: Electrical Specifications**  
**(V<sub>DD</sub> = +3.3 V; 75 Ω system)**

PARAMETER	MIN	TYP	MAX	UNIT	COMMENTS
Gain (Outputs 1-4)	3.0	4.0	-	dB	55 MHz to 1 GHz
Gain (Output 5)	2.5	4.0	-	dB	55 MHz to 1 GHz
Noise Figure	-	4.8	-	dB	Ch 1-4 in "ON" mode
Noise Figure	-	4.2	-	dB	Ch 5 in "ON" mode
CTB	-	-70	-60	dBc	See note 1
CSO	-	-60	-56	dBc	See note 1
XMOD	-	-67	-	dBc	See note 1
Isolation Between Output and Any Other Output Port	-	25	-	dB	
Isolation Between Control Input and Outputs	-	-20	-	dB	pin 23 to any output
Isolation Between Input and Output	-	25	-	dB	
Input Return Loss	-	-13	-	dB	"ON" mode
Input Return Loss	-	-20	-	dB	"bypass" mode
Bypass Path Attenuation	-	0.4	0.7	dB	55 MHz
Bypass Path Attenuation	-	1.0	1.5	dB	1 GHz
Shutdown Control Voltage - "ON"	3.0	-	3.3	V	All outputs active
Shutdown Control Voltage - "OFF"	0	-	0.5	V	Phone in bypass mode
Power "ON" Current	100	130	170	mA	
Current in Power Loss Mode	-	0.1	-	uA	Working with external Load Switch SI869DH

**Notes:**

- (1) Distortion measured with 132 NTSC flat analog channels, 15 dBmV/ch input power.
- (2) 3.3 V supply must be maintained for bypass function to work.

PERFORMANCE DATA - S-Parameters

Figure 3: Input Return Loss vs. Frequency

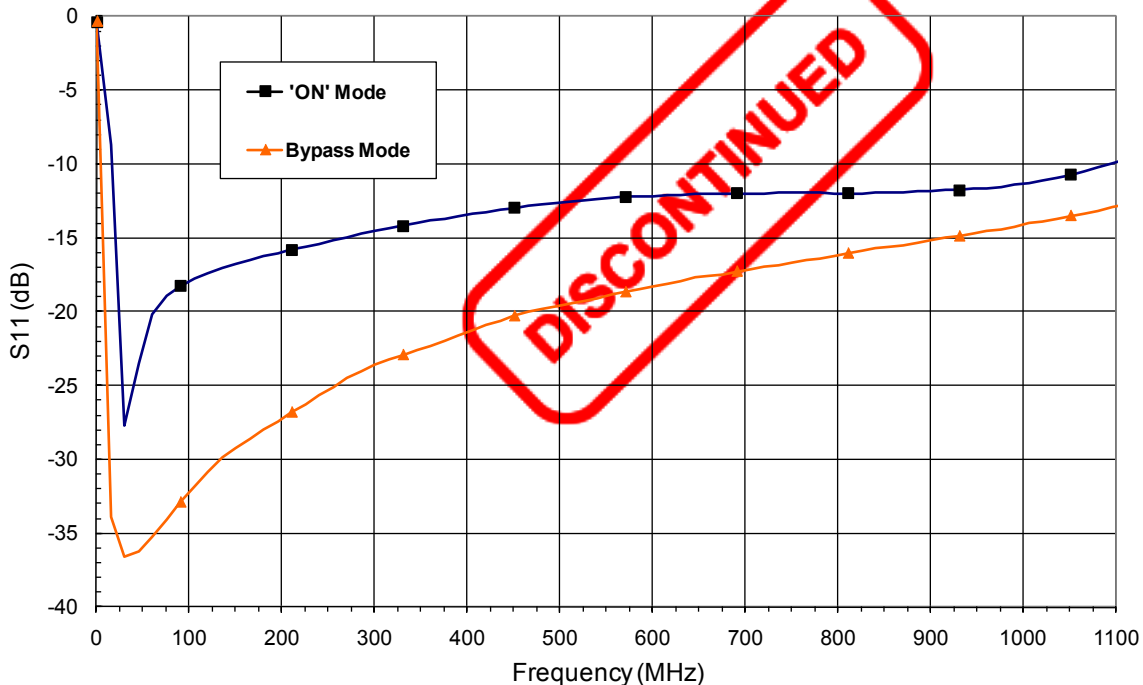

Figure 4: Gain vs. Frequency

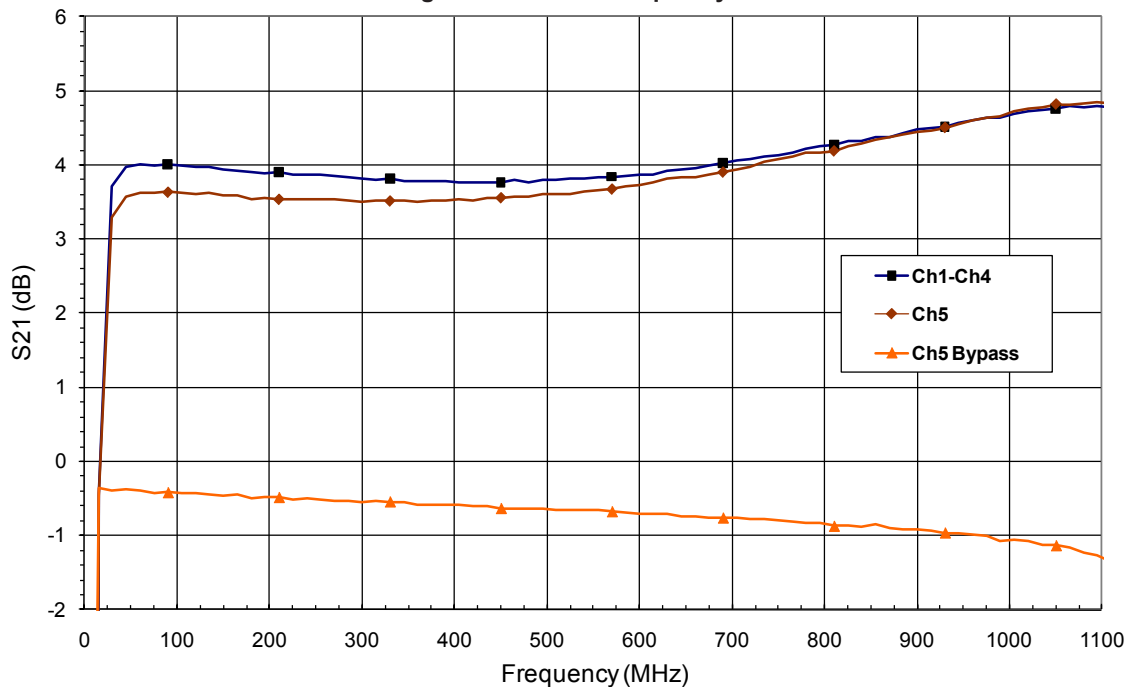

Figure 5: Reverse Isolation vs. Frequency

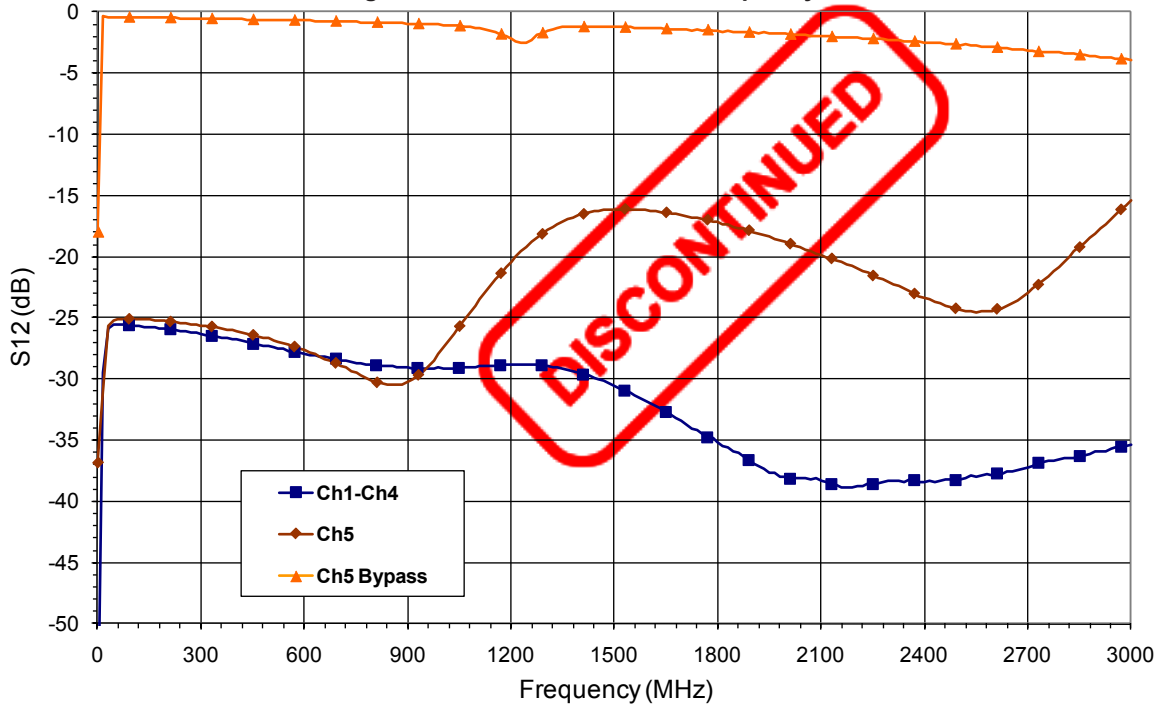

Figure 6: Output Return Loss vs. Frequency

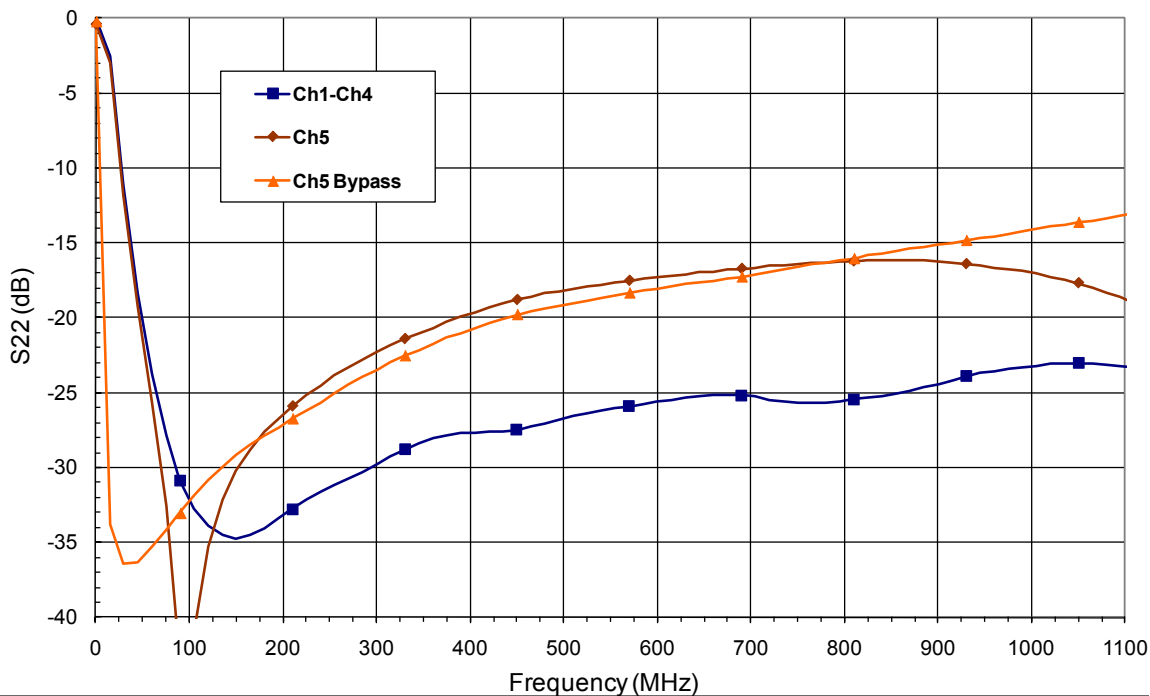

Figure 7: Isolation between Control Input (Pin 23) and Output Pins

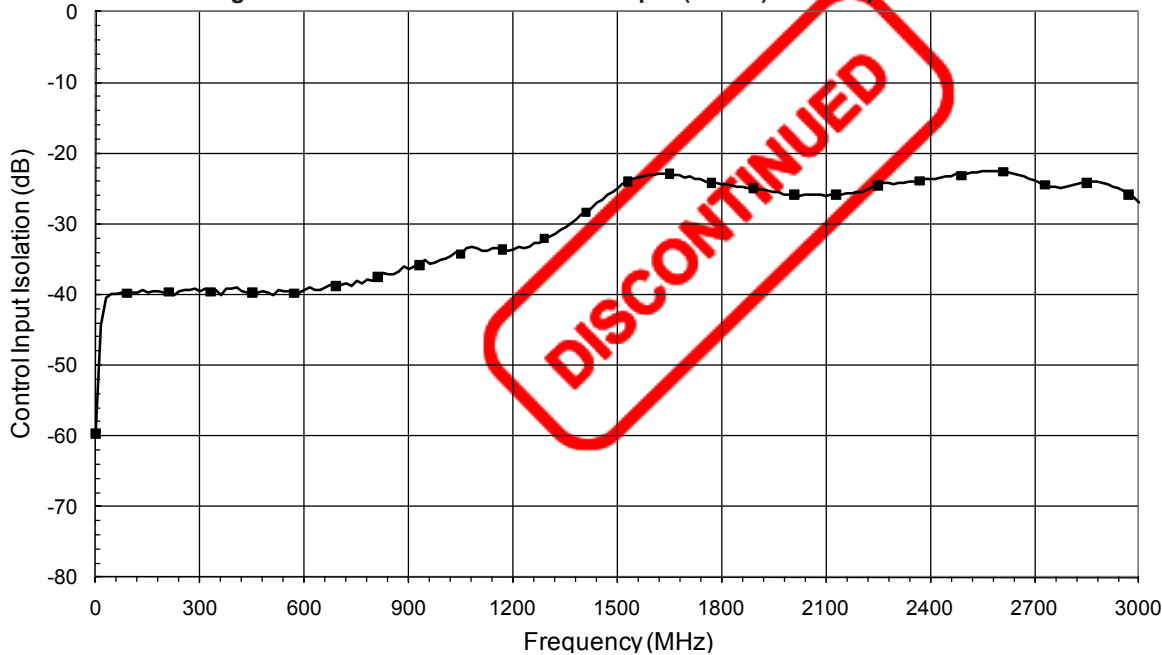

Figure 8: Output-to-Output Isolation vs. Frequency

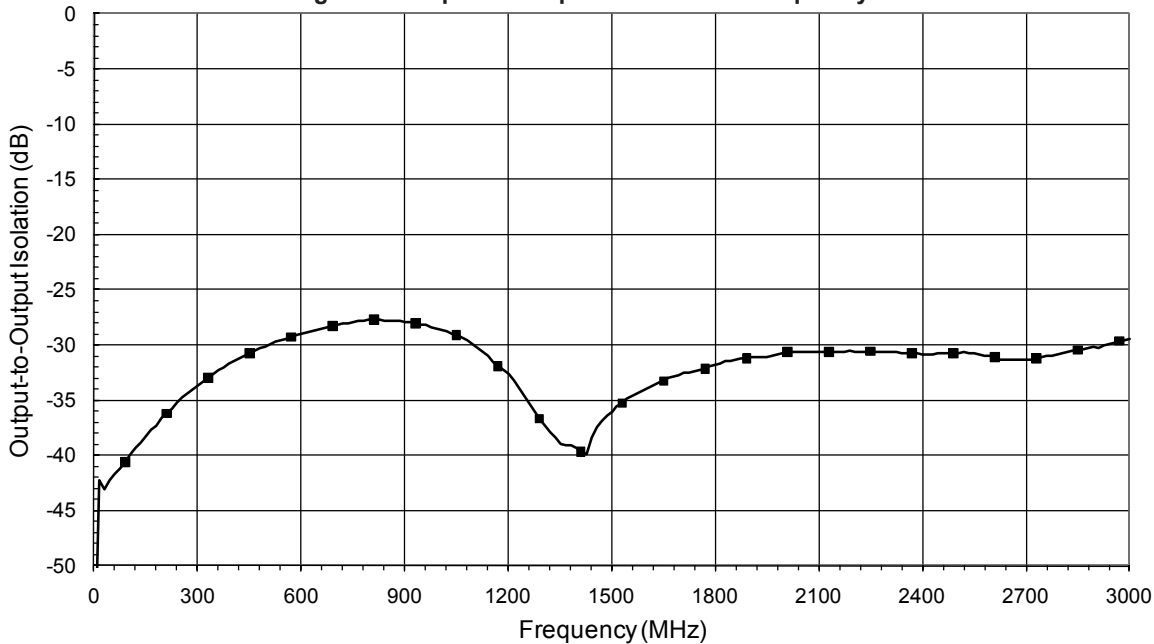

Figure 9: Noise Figure vs. Frequency

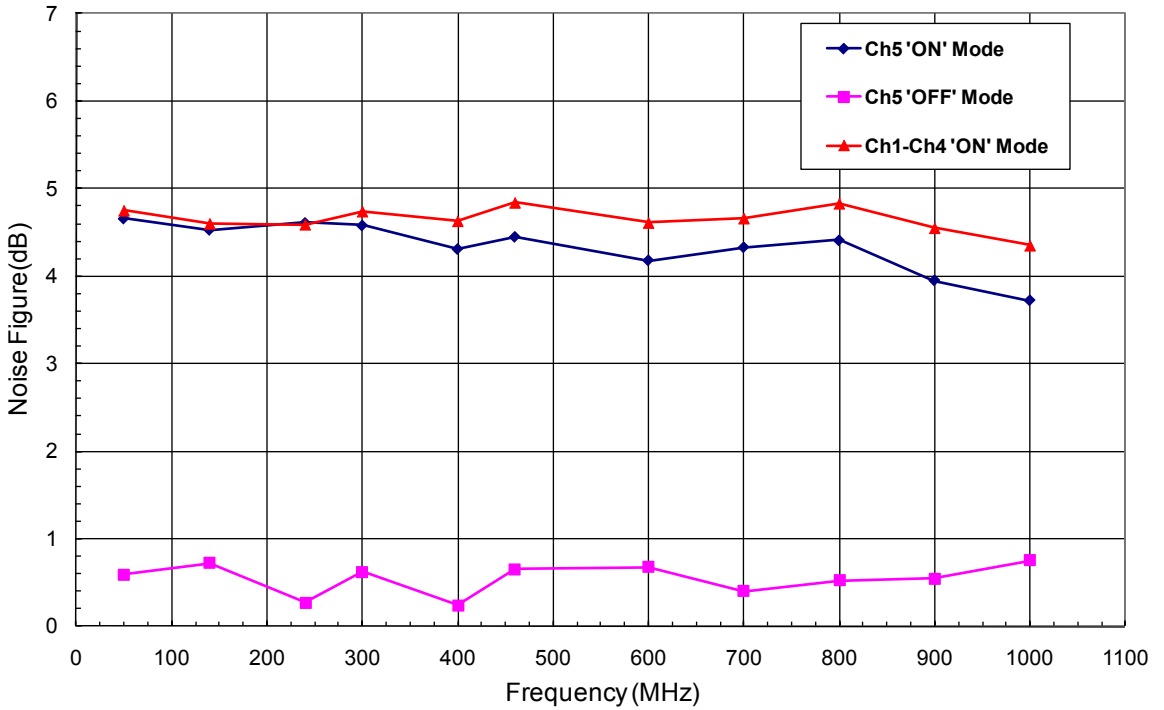
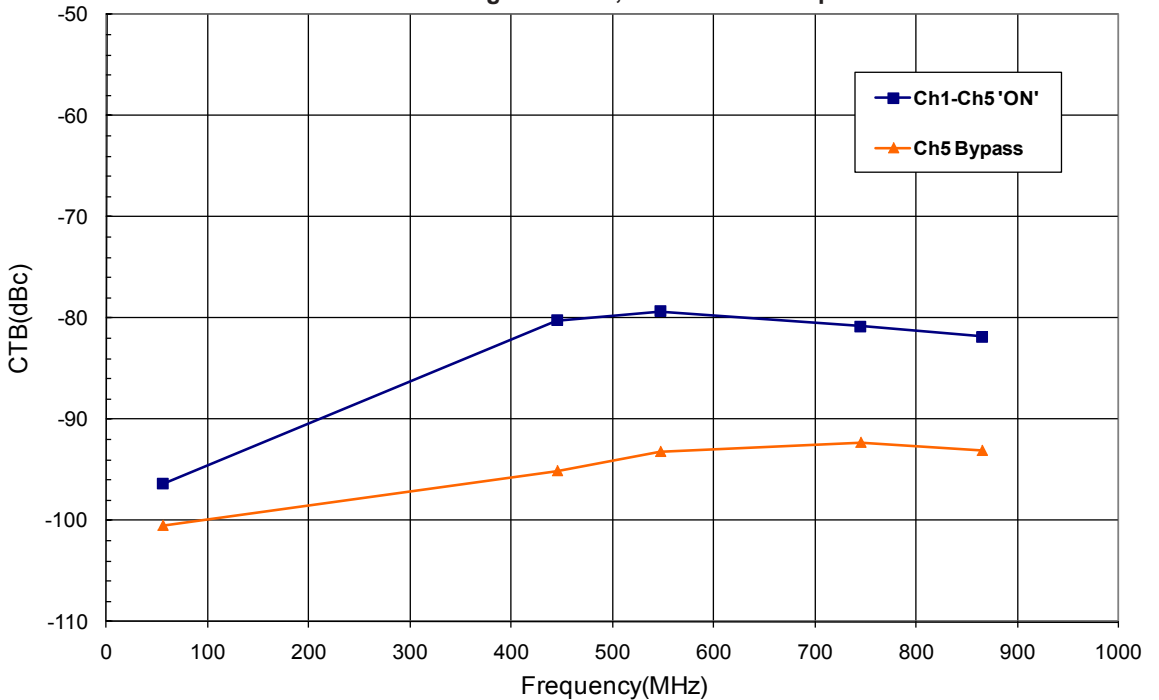
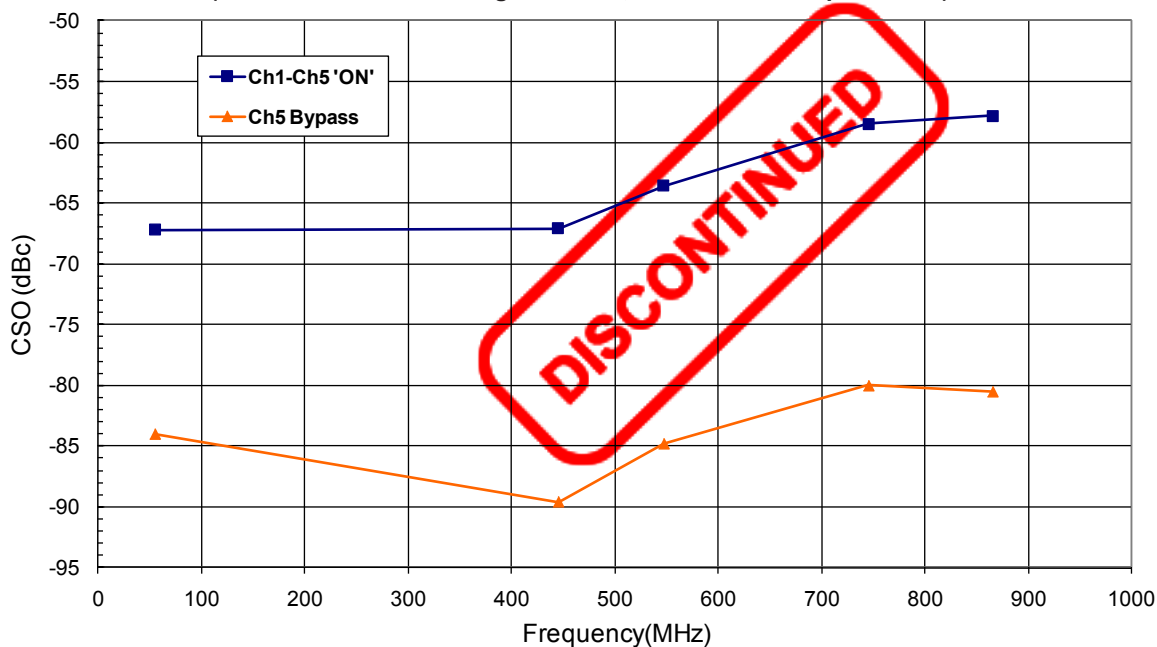

Figure 10: CTB vs. Frequency  
132 Channels Flat Analog Channels, 19 dBmV/Ch Output Power

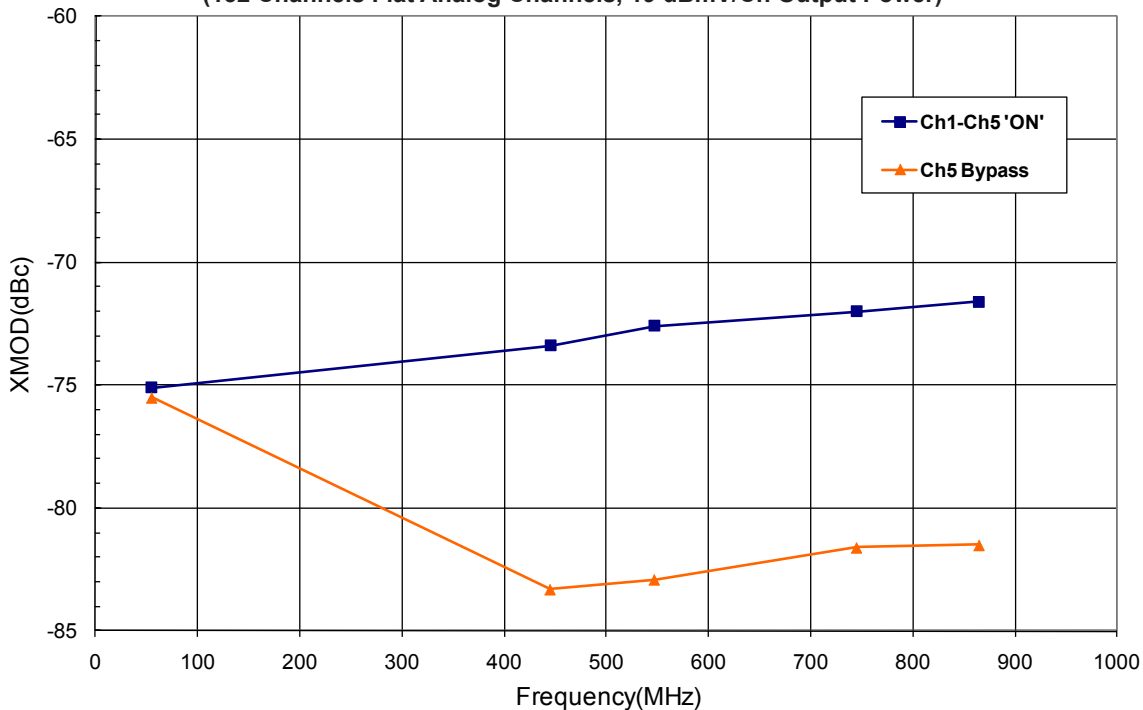



**Figure 11: CSO vs. Frequency**  
 (132 Channels Flat Analog Channels, 19 dBmV/Ch Output Power)



**Figure 12: XMOD vs. Frequency**  
 (132 Channels Flat Analog Channels, 19 dBmV/Ch Output Power)



APS3625  
5 Way Active Power Splitter  
with external MOSFET

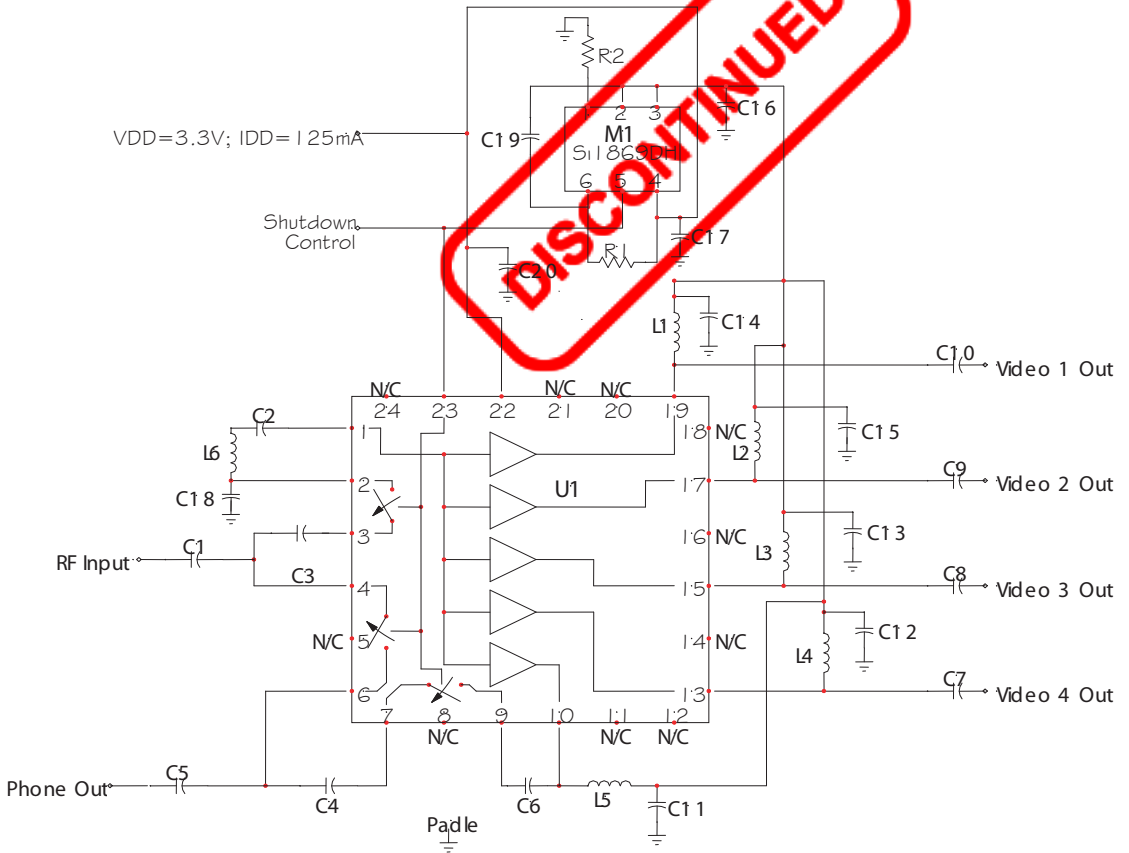

Figure 13: 5-Way Active Power Splitter with external MOSFET

Note:

Pin 22 must have 3.3 V maintained, even during power loss. This is normally accomplished by a battery backup. Upon power loss, the FET load switch (SI 1869DH) cuts off power to the five output amplifiers, and puts the APS3625 in bypass mode.

## APPLICATION INFORMATION

Table 5: Application Bill-of-Materials

Item	Footprint	Description	QTY	Vendor	Vendor Pin
C1, C4, C6, C11, C12, C13,C14, C15, C16, C17, C20	402	0.01 uF Capacitor	10	Murata	GRM155R71H103KA88D
C2, C3	201	0.01 uF Capacitor	2	Murata	GRM033R70J103KA01
C5, C7, C8, C9, C10	402	100 pF Capacitor	5	Murata	GRM155R71H101KA01D
C18	201	0.5 pF Capacitor	1	Johanson Technology	250R05L0R5CV4T
C19	402	1000 pF Capacitor	1	Murata	GRM155R71H102KA88D
L6	201	10 nH Inductor	1	TDK	445-1582-2-ND
R1	402	1 Meg 5% Resistor	1	Panasonic	ERJ-2GEJ105X
R2	402	100 K 5% Resistor	1	Panasonic	ERJ-2GEJ104X
L1, L2, L3, L4, L5	603	470 nH Inductor	5	Coilcraft	0603LS-471XJLB
U1	4 x4 24 pin MLF	5 way Active power Splitter	1	ANADIGICS	APS3625E1
M1	SC70-6	Load Switch with Level shift	1	Vishay Siliconix	SI1869DH-T1_E3

PACKAGE OUTLINE

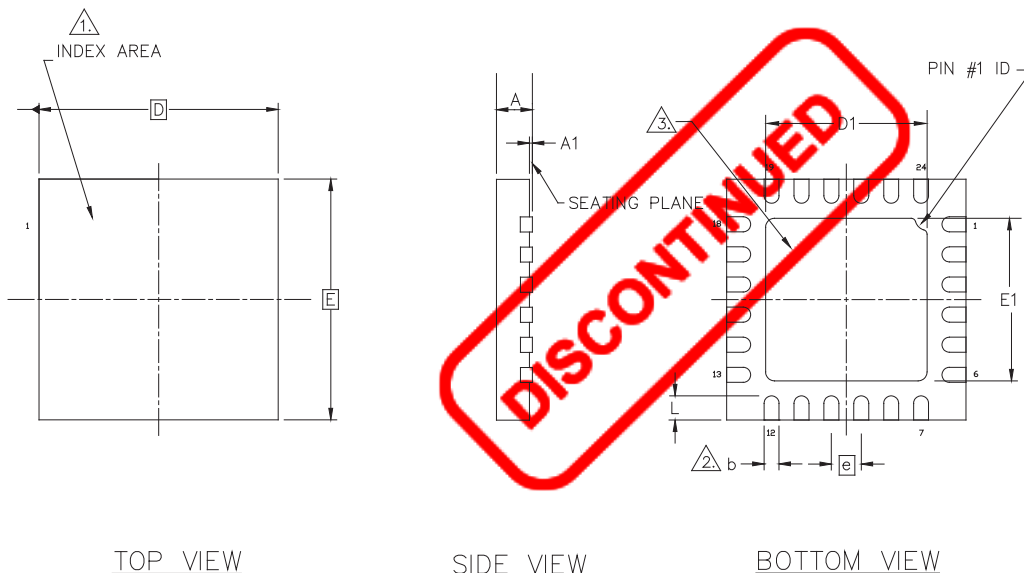

SYMBOL	DIMENSIONS—MM			NOTE
	MIN.	NOM.	MAX.	
A	0.80	0.90	1.00	
A1	0.00	0.02	0.05	
b	0.18	0.250	0.30	
D	4.00 BSC			
D1	2.55	2.70	2.80	
E	4.00 BSC			
E1	2.55	2.70	2.80	
e	0.50 BSC			
L	0.30	0.40	0.50	

NOTES :

- 1. TERMINAL #1 IDENTIFIER AND PAD NUMBERING CONVENTION SHALL CONFORM TO JESD 95-1 SPP-012.
- 2. DIMENSION b APPLIES TO METALLIZED TERMINAL AND IS MEASURED BETWEEN 0.25 AND 0.30mm FROM TERMINAL TIP.
- 3. BILATERAL COPLANARITY ZONE APPLIES TO THE EXPOSED PAD AS WELL AS THE TERMINALS.

Figure 14: S34 Package Outline - 24 Pin 4 mm x 4 mm x 0.9 mm QFN

TOP BRAND

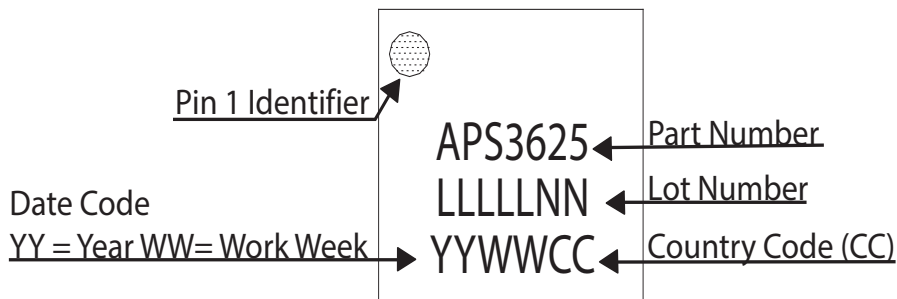
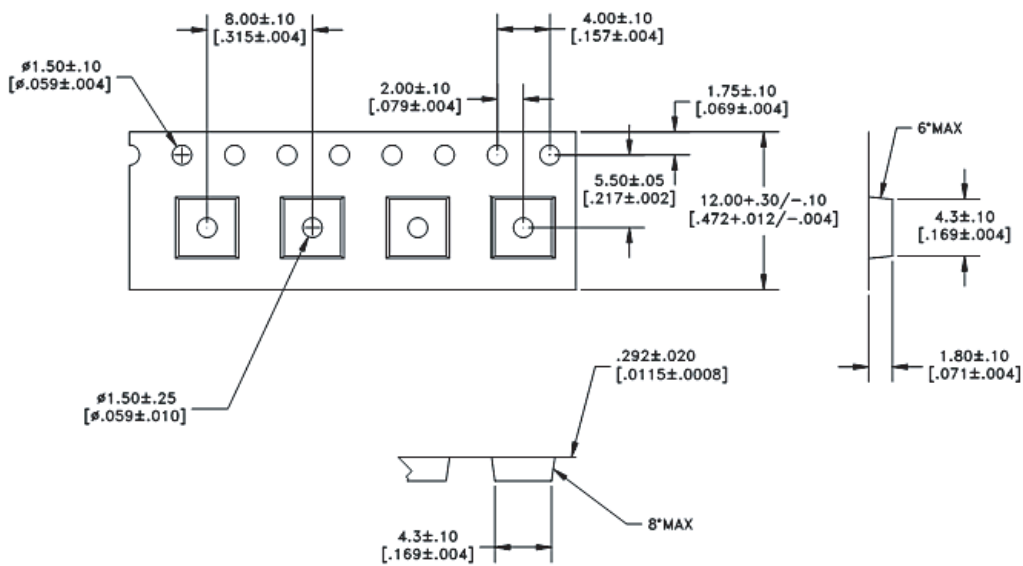

Figure 15: Branding Specification



DIMENSIONS ARE IN MILLIMETERS [INCHES]  
STANDARD TOLERANCES

Figure 16: Tape & Reel Packaging

Table 6: Tape & Reel Dimensions

PACKAGE TYPE	TAPE WIDTH	POCKET PITCH	REEL CAPACITY	MAX REEL DIA
4 mm x 4 mm x 0.9 mm	12 mm	8 mm	2500	13"

**ORDERING INFORMATION**

ORDER NUMBER	TEMPERATURE RANGE	PACKAGE DESCRIPTION	COMPONENT PACKAGING
APS3625RS34P8	-5 °C to +85 °C	24 Pin 4 mm x 4 mm x 0.9 mm LPCC (QFN)	2,500 piece Tape & Reel



Copyright © 2016 Skyworks Solutions, Inc. All Rights Reserved.

Information in this document is provided in connection with Skyworks Solutions, Inc. ("Skyworks") products or services. These materials, including the information contained herein, are provided by Skyworks as a service to its customers and may be used for informational purposes only by the customer. Skyworks assumes no responsibility for errors or omissions in these materials or the information contained herein. Skyworks may change its documentation, products, services, specifications or product descriptions at any time, without notice. Skyworks makes no commitment to update the materials or information and shall have no responsibility whatsoever for conflicts, incompatibilities, or other difficulties arising from any future changes.

No license, whether express, implied, by estoppel or otherwise, is granted to any intellectual property rights by this document. Skyworks assumes no liability for any materials, products or information provided hereunder, including the sale, distribution, reproduction or use of Skyworks products, information or materials, except as may be provided in Skyworks Terms and Conditions of Sale.

THE MATERIALS, PRODUCTS AND INFORMATION ARE PROVIDED "AS IS" WITHOUT WARRANTY OF ANY KIND, WHETHER EXPRESS, IMPLIED, STATUTORY, OR OTHERWISE, INCLUDING FITNESS FOR A PARTICULAR PURPOSE OR USE, MERCHANTABILITY, PERFORMANCE, QUALITY OR NON-INFRINGEMENT OF ANY INTELLECTUAL PROPERTY RIGHT; ALL SUCH WARRANTIES ARE HEREBY EXPRESSLY DISCLAIMED. SKYWORKS DOES NOT WARRANT THE ACCURACY OR COMPLETENESS OF THE INFORMATION, TEXT, GRAPHICS OR OTHER ITEMS CONTAINED WITHIN THESE MATERIALS. SKYWORKS SHALL NOT BE LIABLE FOR ANY DAMAGES, INCLUDING BUT NOT LIMITED TO ANY SPECIAL, INDIRECT, INCIDENTAL, STATUTORY, OR CONSEQUENTIAL DAMAGES, INCLUDING WITHOUT LIMITATION, LOST REVENUES OR LOST PROFITS THAT MAY RESULT FROM THE USE OF THE MATERIALS OR INFORMATION, WHETHER OR NOT THE RECIPIENT OF MATERIALS HAS BEEN ADVISED OF THE POSSIBILITY OF SUCH DAMAGE.

Skyworks products are not intended for use in medical, lifesaving or life-sustaining applications, or other equipment in which the failure of the Skyworks products could lead to personal injury, death, physical or environmental damage. Skyworks customers using or selling Skyworks products for use in such applications do so at their own risk and agree to fully indemnify Skyworks for any damages resulting from such improper use or sale.

Customers are responsible for their products and applications using Skyworks products, which may deviate from published specifications as a result of design defects, errors, or operation of products outside of published parameters or design specifications.

Customers should include design and operating safeguards to minimize these and other risks. Skyworks assumes no liability for applications assistance, customer product design, or damage to any equipment resulting from the use of Skyworks products outside of stated published specifications or parameters.

Skyworks and the Skyworks symbol are trademarks or registered trademarks of Skyworks Solutions, Inc., in the United States and other countries. Third-party brands and names are for identification purposes only, and are the property of their respective owners. Additional information, including relevant terms and conditions, posted at [www.skyworksinc.com](http://www.skyworksinc.com), are incorporated by reference.

**Skyworks Solutions, Inc.**

Phone [781] 376-3000 • Fax [781] 376-3100 • [sales@skyworksinc.com](mailto:sales@skyworksinc.com) • [www.skyworksinc.com](http://www.skyworksinc.com)

Skyworks Proprietary and Confidential information • Products and Product Information are Subject to Change Without Notice