



APPLICATION NOTE

Empirically Determining the VCO Inductor

Many engineers are not familiar with the analytical techniques of using coaxial resonators in Voltage-Controlled Oscillator (VCO) circuits. Typically, the designer needs the equivalent of a high-Quality Factor (Q) inductor to resonate with a varactor, and an excellent choice is a ceramic coaxial line with a Self-Resonant Frequency (SRF) that is approximately 15% higher than the VCO's center frequency (fo).

If a circuit simulation is not used to determine the exact input impedance of the coaxial line that the active circuit prefers, a few resonator samples could be ordered with SRFs that are somewhat higher than fo. This wait-and-try cycle can be slashed by using a conventional 50 Ω coaxial line that is readily available, such as a 0.085-inch semi-rigid cable. This interim measure does not give a great Q, temperature performance, or even the same tuning slope as the ceramic resonator, but nails down the impedance at fo and provides a very good estimate for specifying the ceramic coaxial prototype.

This technique works for circuit topologies where one end of the VCO circuit inductor is at the RF ground, but not necessarily the d-c ground. This is because the ceramic coaxial line is preferably mounted on the circuit board with its outer metallization at RF ground. Otherwise, the outer conductor is RF "hot," and could radiate to nearby circuits, which defeats the preferable self-shielding nature of the coaxial resonator.

The coaxial line can be either short-circuited or open-circuited at one end. With the correct length, the line still presents an inductive reactance at the active circuit end to allow a short piece of 50 Ω coaxial to work well in the breadboard circuit—but remember to provide a complete d-c path for the varactor bias.

Figure 1 shows an example of a typical VCO schematic that illustrates this technique. The "temporary" 50 Ω coaxial line's center conductor is connected to the junction of the 3.3 pF capacitors, and the shield at the same end of the coaxial is connected to a good RF ground point. Grounding the shield along its entire length is optional, and if the far end is left free, the line length can be progressively snipped off at the open end until the circuit oscillates at 900 MHz.

To determine the coaxial length, start with a half-wave length (λG/2) at 900 MHz in the coaxial dielectric. As the open-ended line is trimmed shorter than a half-wave, an equivalent inductance displays at the active circuit's end. If the coaxial dielectric constant (εR) is 2.01, then a half-wave at 900 MHz is a length of coaxial, as follows:

$$\lambda_G = \frac{11,803}{2F_0\sqrt{\epsilon_R}} = \frac{11,803}{2(900)\sqrt{2.01}} = 4.625 \text{ inches} \tag{1}$$

When the line is trimmed to run the VCO at 900 MHz, unsolder the 50 Ω coaxial and measure its impedance at the circuit connection end. A network analyzer gives the equivalent inductive reactance at 900 MHz. If there is no analyzer available, measure the trimmed coaxial jacket length (l) and approximate the equivalent reactance as follows:

$$X_{EQV} = \frac{-j}{\tan\left(\frac{\pi l}{\lambda_G/2}\right)} Z_0 \Omega \tag{2}$$

The value of λG is determined by Equation (1).

The argument of the tangent is in radians. For example, if the 50 Ω (Zo) coaxial-trimmed length is 3.137 inches, then XEQV = j31.33 Ω, which is also equivalent to 5.54 nH at 900 MHz. This value can be used with Skyworks CARD/COAX software in the inductor mode to specify a ceramic coaxial resonator. The software includes the effects of the ceramic resonator's tab inductance, and offers part choices that provide XEQV. Choose the part that makes the ceramic coaxial line element SRF as high as possible above 900 MHz. In this case, the choices for a ceramic coaxial line with XEQV = j28.75 Ω at 900 MHz are:

- Part number SR8800LPQ1308BY with SRF at 1308 MHz and an unloaded Qu of 308 (the best choice).
- If a better Qu is necessary, use part number SR8800SPQ1160BY with SRF at 1160 MHz and Qu = 442.

APPLICATION NOTE • EMPIRICALLY DETERMINING THE VCO INDUCTOR

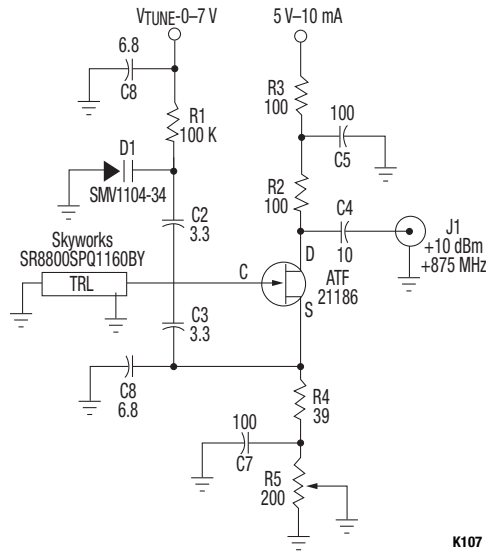

Figure 1. Example of a 900 MHz VCO Schematic

Copyright © 2013, 2017 Trans-Tech Inc., All Rights Reserved.

Information in this document is provided in connection with Trans-Tech, Inc. ("Trans-Tech"), a wholly-owned subsidiary of Skyworks Solutions, Inc. These materials, including the information contained herein, are provided by Trans-Tech as a service to its customers and may be used for informational purposes only by the customer. Trans-Tech assumes no responsibility for errors or omissions in these materials or the information contained herein. Trans-Tech may change its documentation, products, services, specifications or product descriptions at any time, without notice. Trans-Tech makes no commitment to update the materials or information and shall have no responsibility whatsoever for conflicts, incompatibilities, or other difficulties arising from any future changes.

No license, whether express, implied, by estoppel or otherwise, is granted to any intellectual property rights by this document. Trans-Tech assumes no liability for any materials, products or information provided hereunder, including the sale, distribution, reproduction or use of Trans-Tech products, information or materials, except as may be provided in Trans-Tech Terms and Conditions of Sale.

THE MATERIALS, PRODUCTS, AND INFORMATION ARE PROVIDED "AS IS" WITHOUT WARRANTY OF ANY KIND, WHETHER EXPRESS, IMPLIED, STATUTORY, OR OTHERWISE, INCLUDING FITNESS FOR A PARTICULAR PURPOSE OR USE, MERCHANTABILITY, PERFORMANCE, QUALITY, OR NON-INFRINGEMENT OF ANY INTELLECTUAL PROPERTY RIGHT; ALL SUCH WARRANTIES ARE HEREBY EXPRESSLY DISCLAIMED. TRANS-TECH DOES NOT WARRANT THE ACCURACY OR COMPLETENESS OF THE INFORMATION, TEXT, GRAPHICS, OR OTHER ITEMS CONTAINED WITHIN THESE MATERIALS. TRANS-TECH SHALL NOT BE LIABLE FOR ANY DAMAGES, INCLUDING BUT NOT LIMITED TO ANY SPECIAL, INDIRECT, INCIDENTAL, STATUTORY, OR CONSEQUENTIAL DAMAGES, INCLUDING WITHOUT LIMITATION, LOST REVENUES OR LOST PROFITS THAT MAY RESULT FROM THE USE OF THE MATERIALS OR INFORMATION, WHETHER OR NOT THE RECIPIENT OF MATERIALS HAS BEEN ADVISED OF THE POSSIBILITY OF SUCH DAMAGE.

Trans-Tech products are not intended for use in medical, lifesaving, or life-sustaining applications, or other equipment in which the failure of the Trans-Tech products could lead to personal injury, death, or physical or environmental damage. Trans-Tech customers using or selling Trans-Tech products for use in such applications do so at their own risk and agree to fully indemnify Trans-Tech for any damages resulting from such improper use or sale.

Customers are responsible for their products and applications using Trans-Tech products, which may deviate from published specifications as a result of design defects, errors, or operation of products outside of published parameters or design specifications. Customers should include design and operating safeguards to minimize these and other risks. Trans-Tech assumes no liability for applications assistance, customer product design, or damage to any equipment resulting from the use of Trans-Tech products outside of stated published specifications or parameters.

Skyworks and the Skyworks symbol are trademarks or registered trademarks of Skyworks Solutions, Inc., in the United States and other countries. Third-party brands and names are for identification purposes only, and are the property of their respective owners.