

DATA SHEET

SKY13347-360LF: 0.5 to 4.0 GHz SPST Switch, 50 Ω Terminated

Applications

- Wireless infrastructure systems

Features

- 50 Ω terminated RF output
- Low insertion loss: 0.7 dB @ 2.0 GHz
- High isolation: 35 dB @ 2.0 GHz
- Small, DFN (8-pin, 2 x 2 mm) package (MSL1, 260 °C per JEDEC J-STD-020)
- For RoHS and other product compliance information, see the [Skyworks Certificate of Conformance](#)

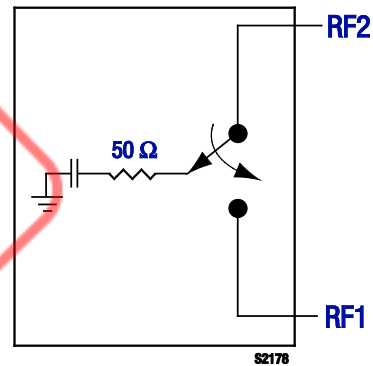

Figure 1. SKY13347-360LF Block Diagram

Description

The SKY13347-360LF is a pHEMT GaAs single-pole, single-throw (SPST) switch with a 50 Ω terminated output. The high linearity performance, low insertion loss, and high isolation achieved by the SKY13347-360LF make it an ideal choice for many cellular and wireless infrastructure applications.

The switch is manufactured in a compact, 2 x 2 mm, 8-pin Dual Flat No-Lead (DFN) package.

A functional block diagram is shown in Figure 1. The pin configuration and package are shown in Figure 2. Signal pin assignments and functional pin descriptions are provided in Table 1.

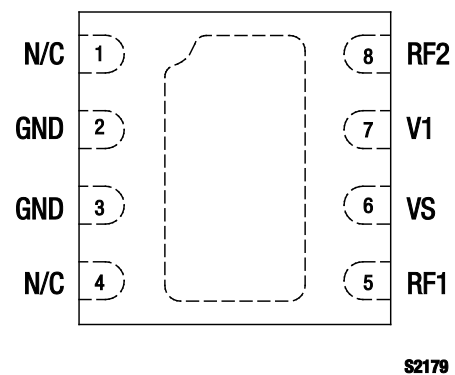

Figure 2. SKY13347-360LF Pinout (Top View)

Table 1. SKY13347-360LF Signal Descriptions

Pin	Name	Description	Pin	Name	Description
1	N/C	No connection. May be connected to ground with no change in performance.	5	RF1	RF port 1. Must be DC blocked.
2	GND	Ground	6	VS	DC bias voltage. Refer to Table 4.
3	GND	Ground	7	V1	DC control voltage. Refer to Table 4.
4	N/C	No connection. May be connected to ground with no change in performance.	8	RF2	RF port 2. Must be DC blocked.

Functional Description

Switching is controlled by a single control voltage on the V1 pin. Depending on the logic applied to the control pin, the RF1 and RF2 signals (pins 5 and 8, respectively) are connected to each other either by a low insertion loss path or a high isolation path.

Both RF ports of the switch require DC blocking capacitors. The value of either blocking capacitor determines the low frequency of operation.

Electrical and Mechanical Specifications

The absolute maximum ratings of the SKY13347-360LF are provided in Table 2. Electrical specifications are provided in Table 3.

Typical performance characteristics of the SKY13347-360LF are illustrated in Figures 3 through 8.

The state of the SKY13347-360LF is determined by the logic provided in Table 4.

Table 2. SKY13347-360LF Absolute Maximum Ratings (Note 1)

Parameter	Symbol	Minimum	Maximum	Units
DC supply voltage	Vs		6	V
Input power for TOP < 85 °C	PIN		+32	dBm
Input power for 85 °C < TOP < 105 °C	PIN		+20	dBm
Control voltage	V1		Vs	V
Operating temperature (PINMAX = +20 dBm for TOP = +105 °C)	TOP	-40	+105	°C
Storage temperature	TSTG	-40	+125	°C

Note 1: Exposure to maximum rating conditions for extended periods may reduce device reliability. There is no damage to device with only one parameter set at the limit and all other parameters set at or below their nominal value. Exceeding any of the limits listed here may result in permanent damage to the device.

CAUTION: Although this device is designed to be as robust as possible, electrostatic discharge (ESD) can damage this device. This device must be protected at all times from ESD. Static charges may easily produce potentials of several kilovolts on the human body or equipment, which can discharge without detection. Industry-standard ESD precautions should be used at all times.

Table 3. SKY13347-360LF Electrical Specifications (Note 1)**(V1 = 0 V and +3.0 V, T_{OP} = +25 °C, P_{IN} = 0 dBm, Characteristic Impedance [Z₀] = 50 Ω, C_{BLK} = 47 pF, Unless Otherwise Noted)**

Parameter	Symbol	Test Condition	Min	Typical	Max	Units
Insertion loss	IL	RF1 to RF2:				
		0.5 GHz		0.50	0.60	dB
		1.0 GHz		0.55	0.65	dB
		1.5 GHz		0.60	0.70	dB
		2.0 GHz		0.60	0.70	dB
		2.5 GHz		0.65	0.75	dB
		3.0 GHz		0.70	0.80	dB
4.0 GHz		0.75	0.85	dB		
Isolation	Iso	RF1 to RF2:				
		0.5 GHz	40	45		dB
		1.0 GHz	30	35		dB
		1.5 GHz	30	35		dB
		2.0 GHz	30	35		dB
		2.5 GHz	25	30		dB
		3.0 GHz	25	30		dB
4.0 GHz	25	28		dB		
Return loss	RL	RF1 and RF2 in insertion loss state:				
		0.5 GHz to 3.0 GHz		20		dB
		3.0 GHz to 4.0 GHz		15		dB
		RF2 in isolation loss state:				
0.5 GHz to 3.0 GHz		15		dB		
3.0 GHz to 4.0 GHz		12		dB		
1 dB input compression point	IP1dB	0.5 to 3.0 GHz		+31		dBm
		3.0 to 4.0 GHz @ V1 = 5 V		+33		dBm
Third order input intercept point	IIP3	P _{IN} = +5 dBm/tone, 1 MHz spacing:				
		0.5 to 3.0 GHz		+40		dBm
		3.0 GHz to 4.0 GHz @ V1 = 5 V		+43		dBm
Switching speed		10% to 90% RF		70		ns
		90% to 10% RF		10		ns
		50% V1 to 90% RF		85		ns
		50% V1 to 10% RF		10		ns

Note 1: Performance is guaranteed only under the conditions listed in this table.

Typical Performance Characteristics

(V1 = 0 V and +3.0 V, Top = +25 °C, Pin = 0 dBm, Characteristic Impedance [Zo] = 50 Ω, CBLK = 47 pF, Unless Otherwise Noted)

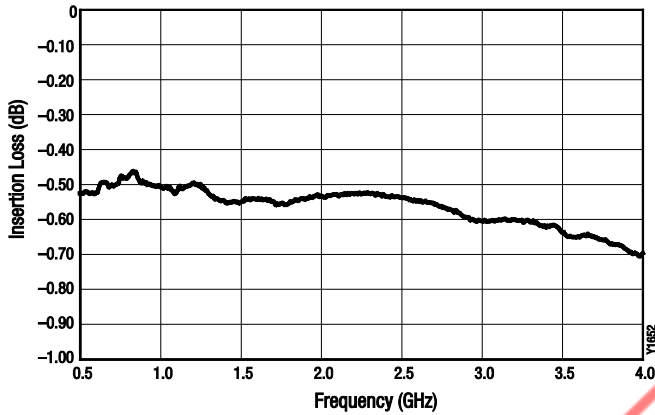

Figure 3. RF1 to RF2 Insertion Loss vs Frequency

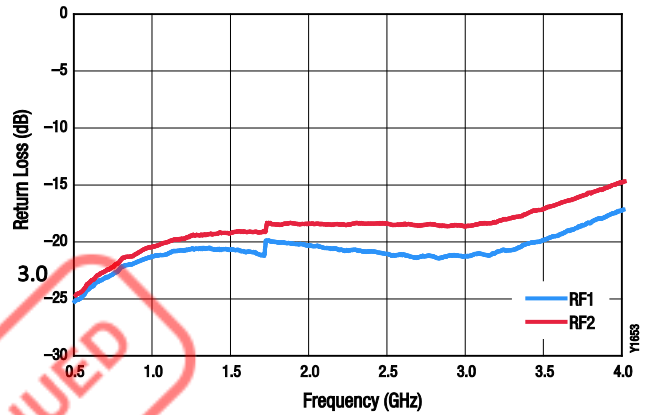

Figure 4. Return Loss (Insertion Loss State) vs Frequency

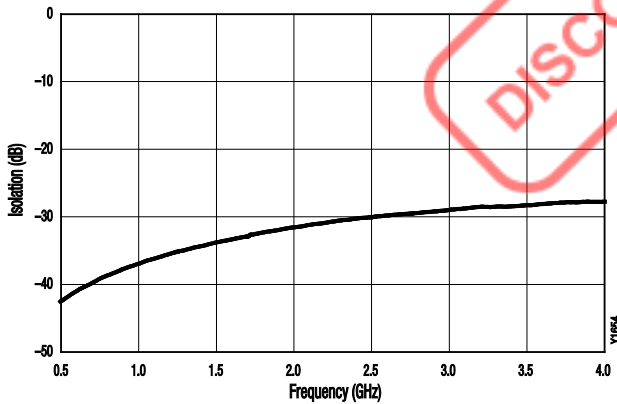

Figure 5. Isolation vs Frequency

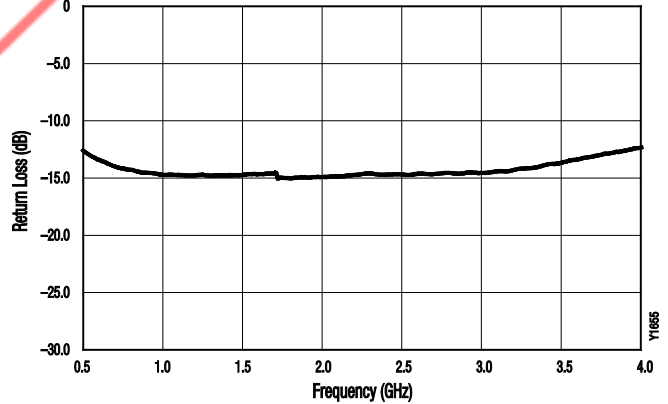

Figure 6. RF2 Return Loss (Isolation State) vs Frequency

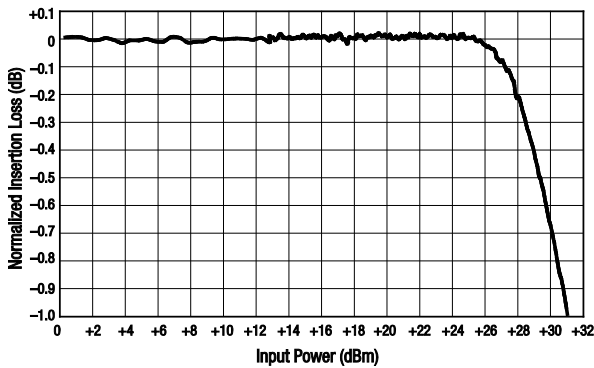

Figure 7. Normalized Insertion Loss vs Input Power
@ 3 GHz, V1 = 3 V

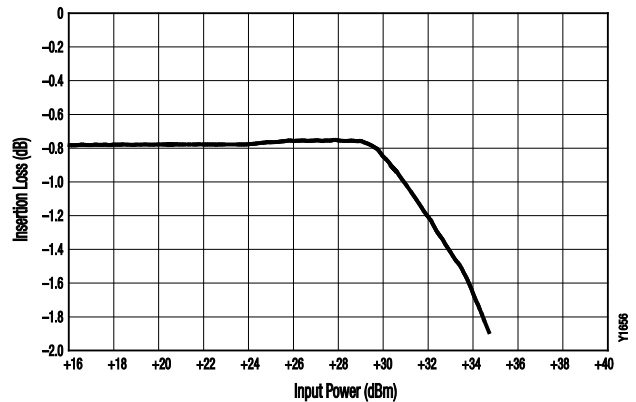

Figure 8. Insertion Loss vs Input Power
@ 3.6 GHz, V1 = 5 V

DISCONTINUED

Table 4. SKY13347-360LF Truth Table

VS (Pin 6)	V1 (Pin 7)	RF State
1	0	Isolation
1	VS	Insertion loss

Note: "1" = +1.8 V to +5.0 V. "0" = 0 V to +0.2 V. Any state not described in this table places the switch into an undefined state. An undefined state will not damage the device.

Evaluation Board Description

The SKY13347-360LF Evaluation Board is used to test the performance of the SKY13347-360LF SPDT Switch. An Evaluation Board schematic diagram is provided in Figure 9. An assembly drawing for the Evaluation Board is shown in Figure 10.

Package Dimensions

The PCB layout footprint for the SKY13347-360LF is provided in Figure 11. Typical part markings are shown in Figure 12. Package dimensions are shown in Figure 13, and tape and reel dimensions are provided in Figure 14.

Package and Handling Information

Instructions on the shipping container label regarding exposure to moisture after the container seal is broken must be followed. Otherwise, problems related to moisture absorption may occur when the part is subjected to high temperature during solder assembly.

The SKY13347-360LF is rated to Moisture Sensitivity Level 1 (MSL1) at 260 °C. It can be used for lead or lead-free soldering. For additional information, refer to the Skyworks Application Note, *Solder Reflow Information*, document number 200164.

Care must be taken when attaching this product, whether it is done manually or in a production solder reflow environment. Production quantities of this product are shipped in a standard tape and reel format.

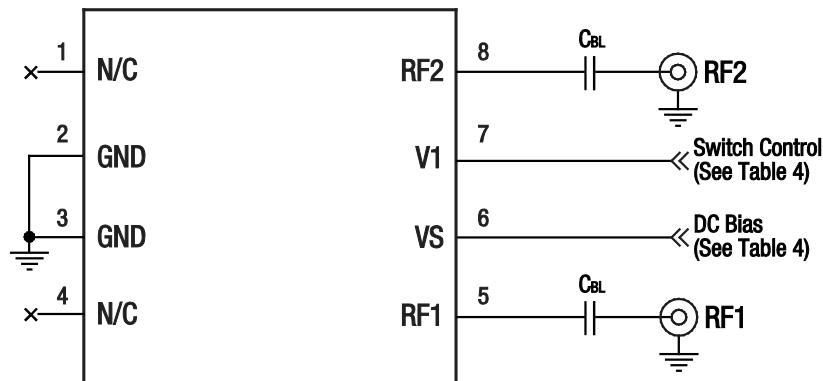

Note: $C_{BL} = 47\text{ pF}$ for >500 MHz operation; 220 pF for operation down to 50 MHz. Higher values recommended for lower frequency operation. Exposed paddle must be grounded.

S2180

Figure 9. SKY13347-360LF Evaluation Board Schematic

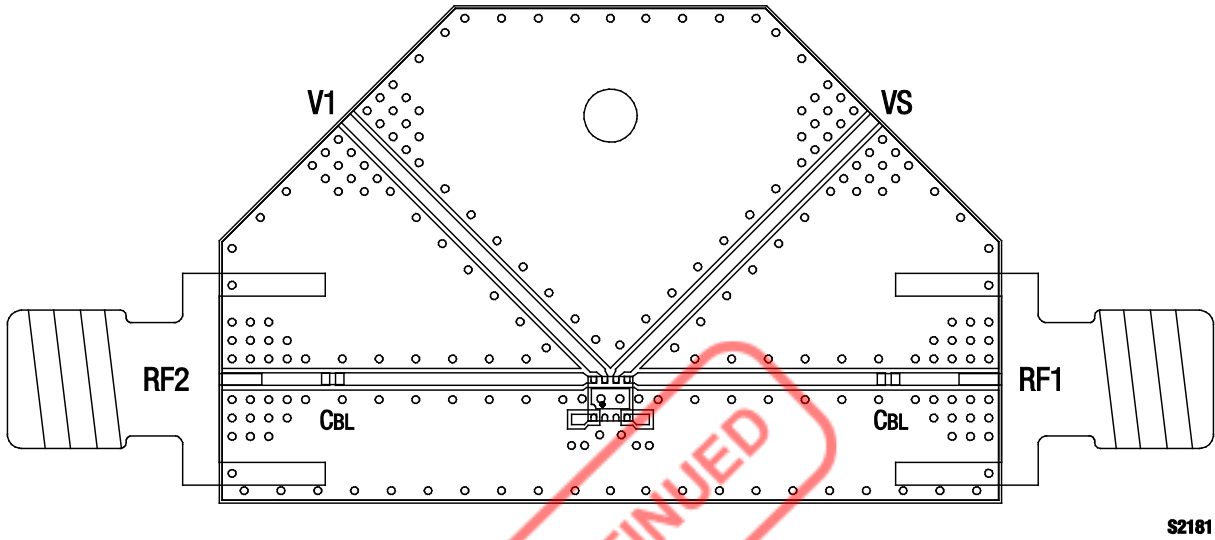
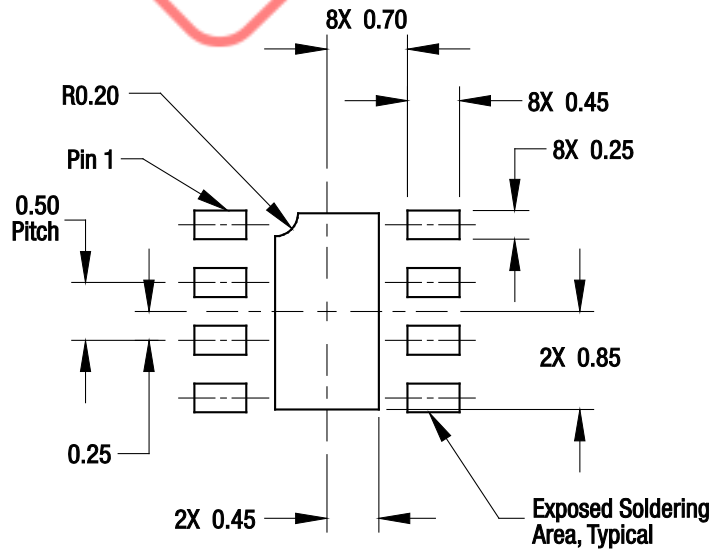

Figure 10. SKY13347-360LF Evaluation Board Assembly Diagram



All dimensions are in millimeters.

S1477

Figure 11. SKY13347-360LF PCB Layout Footprint (Top View)

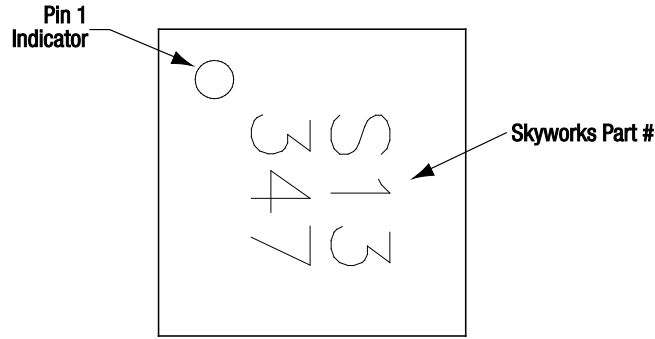
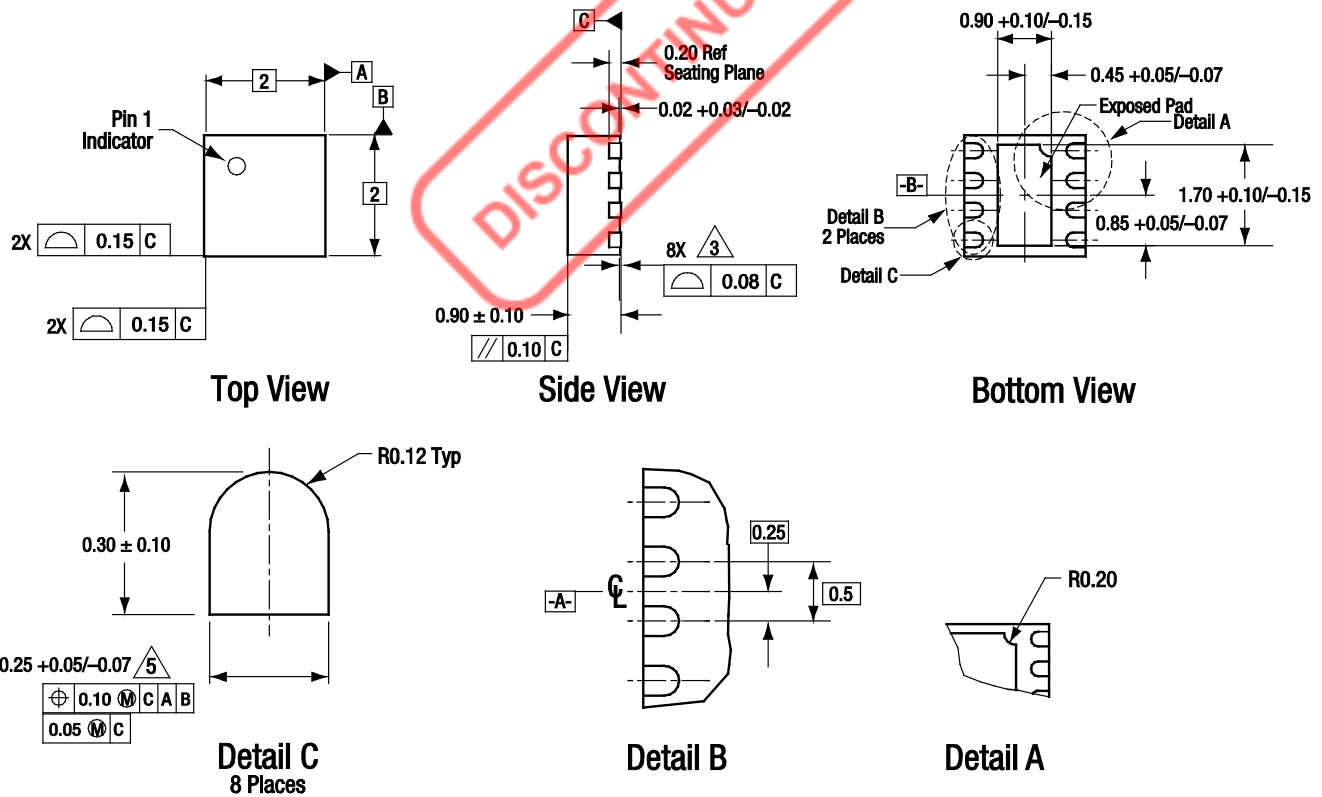

Figure 12. Typical Part Markings (Top View)



All measurements are in millimeters.
 Dimensioning and tolerancing according to ASME Y14.5M-1994.
 Coplanarity applies to the exposed heat sink slug as well as the terminals.
 Plating requirement per source control drawing (SCD) 2504.
 Dimension applies to metallized terminal and is measured between 0.15 mm and 0.30 mm from terminal tip.

S1415

Figure 13. SKY13347-360LF Package Dimensions

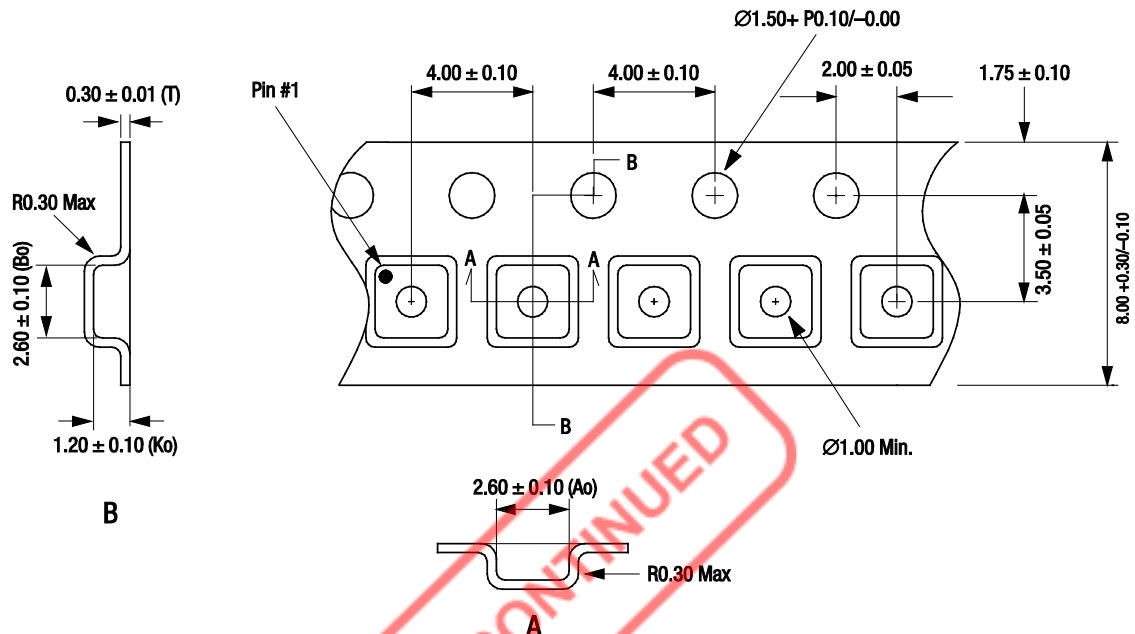

- Notes:
1. Carrier tape: black conductive polystyrene.
 2. Cover tape material: transparent conductive HSA.
 3. Cover tape size: 5.40 mm width.
 4. All measurements are in millimeters.

S1480

Figure 14. SKY13347-360LF Tape and Reel Dimensions

Ordering Information

Model Name	Manufacturing Part Number	Evaluation Kit Part Number
SKY13347-360LF: SPST Switch	SKY13347-360LF	SKY13347-360LF-EVB



Copyright © 2010, 2015, 2026, Skyworks Solutions, Inc. All Rights Reserved.

Information in this document is provided in connection with Skyworks Solutions, Inc., and its subsidiaries (“Skyworks”) products or services. These materials, including the information contained herein, are provided by Skyworks as a service to its customers and may be used for informational purposes only by the customer. Skyworks assumes no responsibility for errors or omissions in these materials or the information contained herein. Skyworks may change its documentation, products, services, specifications or product descriptions at any time, without notice. Skyworks makes no commitment to update the materials or information and shall have no responsibility whatsoever for conflicts, incompatibilities, or other difficulties arising from any future changes.

No license, whether express, implied, by estoppel or otherwise, is granted to any intellectual property rights by this document. Skyworks assumes no liability for any materials, products or information provided hereunder, including the sale, distribution, reproduction or use of Skyworks products, information or materials, except as may be provided in Skyworks’ Terms and Conditions of Sale.

THE INFORMATION IN THIS DOCUMENT AND THE MATERIALS AND PRODUCTS DESCRIBED THEREIN ARE PROVIDED “AS IS” WITHOUT WARRANTY OF ANY KIND, WHETHER EXPRESS, IMPLIED, STATUTORY, OR OTHERWISE, INCLUDING FITNESS FOR A PARTICULAR PURPOSE OR USE, MERCHANTABILITY, PERFORMANCE, QUALITY OR NON-INFRINGEMENT OF ANY INTELLECTUAL PROPERTY RIGHT; ALL SUCH WARRANTIES ARE HEREBY EXPRESSLY DISCLAIMED. SKYWORKS DOES NOT WARRANT THE ACCURACY OR COMPLETENESS OF THE INFORMATION, TEXT, GRAPHICS OR OTHER ITEMS CONTAINED WITHIN THESE MATERIALS. SKYWORKS SHALL NOT BE LIABLE FOR ANY DAMAGES, INCLUDING BUT NOT LIMITED TO ANY SPECIAL, INDIRECT, INCIDENTAL, STATUTORY, OR CONSEQUENTIAL DAMAGES, INCLUDING WITHOUT LIMITATION, LOST REVENUES OR LOST PROFITS THAT MAY RESULT FROM THE USE OF THE MATERIALS OR INFORMATION, WHETHER OR NOT THE RECIPIENT OF MATERIALS HAS BEEN ADVISED OF THE POSSIBILITY OF SUCH DAMAGE.

Skyworks products are not designed, intended, authorized, or warranted for use or inclusion in life support or life endangering applications, devices, or systems where failure or inaccuracy might cause death or personal injury. Skyworks customers agree not to use or sell the Skyworks products for such applications, and further agree to, without limitation, fully defend, indemnify, and hold harmless Skyworks and its agents from and against any and all actions, suits, proceedings, costs, expenses, damages, and liabilities including attorneys’ fees arising out of or in connection with such improper use or sale.

Skyworks assumes no liability for applications assistance, customer product design, or damage to any equipment resulting from the use of Skyworks products outside of Skyworks’ published specifications or parameters. Customers are solely responsible for their products and applications using the Skyworks products.

“Skyworks” and the Skyworks Starburst logo are registered trademarks of Skyworks Solutions, Inc., in the United States and other countries. Third-party brands and names are for identification purposes only and are the property of their respective owners. Additional information, including relevant terms and conditions, posted at www.skyworksinc.com, are incorporated by reference.