

**DATA SHEET**

# SKY12210-478LF: 0.9 to 5.0 GHz, 100 W High-Power Silicon PIN Diode SPDT Switch

**Applications**

- Transmit/receive switching and failsafe switching in TD-SCDMA, WiMAX, and LTE base stations
- Transmit/receive switching in land mobile radios and military communication systems

**Features**

- High-power handling: 100 W CW, 480 W peak
- Low insertion loss: 0.4 dB typical
- High antenna to receive isolation: 44 dB @ 2.6 GHz typical
- Controlled with positive power supply
- Bias driver circuit available on request
- Small QFN (16-pin, 4 x 4 mm) Pb-free package (MSL1, 260 °C per JEDEC J-STD-020)
- For RoHS and other product compliance information, see the [Skyworks Certificate of Conformance](#)

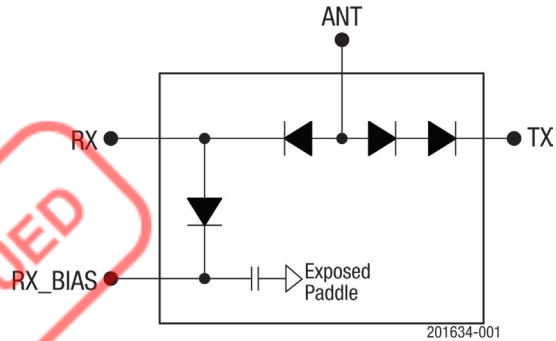
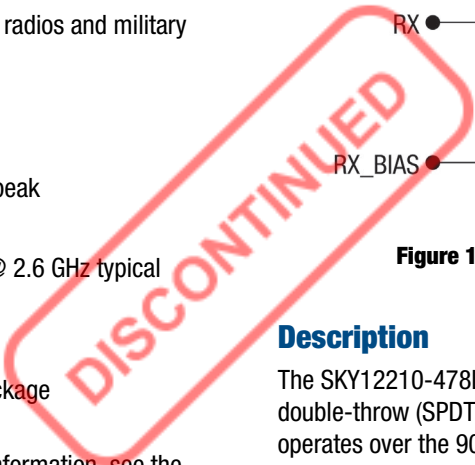

**Figure 1. SKY12210-478LF Block Diagram**

**Description**

The SKY12210-478LF is a high-power handling, single-pole, double-throw (SPDT) silicon PIN diode switch. The device operates over the 900 MHz to 5 GHz band. It features low insertion loss, excellent power handling, and superb linearity with low DC power consumption.

The SKY12210-478LF is well-suited for use as a high-power transmit/receive switch in a variety of telecommunication systems such as WiMAX, TD-SCDMA, and LTE base stations.

The device is provided in a 4 x 4 mm, 16-pin Quad Flat No-Lead (QFN) package. A functional block diagram is shown in Figure 1. The pin configuration and package are shown in Figure 2. Signal pin assignments and functional pin descriptions are provided in Table 1.

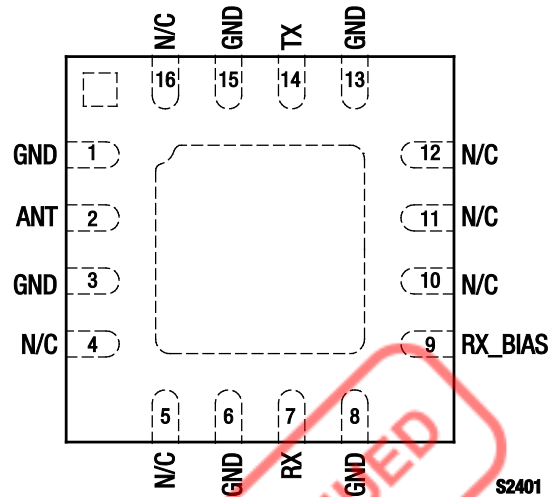

Figure 2. SKY12210-478LF Pinout (Top View)

Table 1. SKY12210-478LF Signal Descriptions

Pin	Name	Description	Pin	Name	Description
1	GND	Ground. Must be connected to ground using lowest possible impedance.	9	RX_BIAS	RF ground port and DC bias input port
2	ANT	Antenna RF port and DC bias input port	10	N/C	No connection
3	GND	Ground. Must be connected to ground using lowest possible impedance.	11	N/C	No connection
4	N/C	No connection	12	N/C	No connection
5	N/C	No connection	13	GND	Ground. Must be connected to ground using lowest possible impedance.
6	GND	Ground. Must be connected to ground using lowest possible impedance.	14	TX	Transmit RF input port and DC bias input port
7	RX	Receive output port and DC bias input port	15	GND	Ground. Must be connected to ground using lowest possible impedance.
8	GND	Ground. Must be connected to ground using lowest possible impedance.	16	N/C	No connection

### Electrical and Mechanical Specifications

The absolute maximum ratings of the SKY12210-478LF are provided in Table 2. Recommended operating conditions are specified in Table 3 and electrical specifications are provided in Table 4.

Typical performance characteristics of the SKY12210-478LF are illustrated in Figures 3 through 9.

The state of the SKY12210-478LF is determined by the logic provided in Table 6. Table 7 provides the logic for use with the SKY12210-478LF Evaluation Board.

Power de-rating data is plotted against temperature in Figures 10 and 11. Equivalent circuit diagrams for transmit and receive are shown in Figure 12.

**Table 2. SKY12210-478LF Absolute Maximum Ratings<sup>1</sup>**

Parameter	Symbol	Minimum	Maximum	Units
RF CW input power, TX and ANT ports (T <sub>SUBSTRATE</sub> = 25 °C)	P <sub>IN</sub>		120	W
RF peak input power, TX and ANT ports (T <sub>SUBSTRATE</sub> = 25 °C, RF burst width = 10 μs, RF burst repetition rate = 25 kHz)	P <sub>IN</sub>		480	W
RF CW input power, RX port (T <sub>SUBSTRATE</sub> = 25 °C)	P <sub>IN</sub>		60	W
RF peak input power, RX port (T <sub>SUBSTRATE</sub> = 25 °C, RF burst width = 10 μs, RF burst repetition rate = 25 kHz)	P <sub>IN</sub>		240	W
Control port reverse voltage	V <sub>CTL</sub>		200	V
Control port forward current	I <sub>CTL</sub>		200	mA
Operating temperature	T <sub>OP</sub>	-55	+175	°C
Storage temperature	T <sub>STG</sub>	-55	+200	°C
Electrostatic discharge:	ESD			
Charged Device Model (CDM), Class 4			1000	V
Human Body Model (HBM), Class 1C			1500	V
Machine Model (MM), Class B			200	V

<sup>1</sup> Exposure to maximum rating conditions for extended periods may reduce device reliability. There is no damage to device with only one parameter set at the limit and all other parameters set at or below their nominal value. Exceeding any of the limits listed here may result in permanent damage to the device.

**ESD HANDLING:** *Although this device is designed to be as robust as possible, electrostatic discharge (ESD) can damage this device. This device must be protected at all times from ESD when handling or transporting. Static charges may easily produce potentials of several kilovolts on the human body or equipment, which can discharge without detection. Industry-standard ESD handling precautions should be used at all times.*

**Table 3. Recommended Operating Conditions (Per ANT, TX, RX, and RX\_BIAS Inputs)**

Parameter	Symbol	Min	Typ	Max	Units
Control port reverse voltage	V <sub>CTL</sub>	5	28	100	V
ANT control port forward current (TX mode)	I <sub>CTL</sub>	50	100	150	mA
ANT control port forward current (RX mode)	I <sub>CTL</sub>	50	133	150	mA
RX_BIAS control port forward current (TX mode)	I <sub>CTL</sub>	50	100	150	mA

**Table 4. SKY12210-478LF Electrical Specifications<sup>1</sup> (1 of 2)**  
**(T<sub>OP</sub> = +25 °C, Characteristic Impedance [Z<sub>0</sub>] = 50 Ω, EVB Optimized for 2.6 GHz Operation, Unless Otherwise Noted)**

Parameter	Symbol	Test Condition	Min	Typ	Max	Units
Insertion loss, TX to ANT ports	IL <sub>TX-ANT</sub>	V <sub>PIN_2</sub> = 2 V, I <sub>PIN_14</sub> = -100 mA, I <sub>PIN_9</sub> = -100 mA, V <sub>PIN_7</sub> = 28 V, TX port P <sub>IN</sub> @ pin 14 = 0 dBm:				
		900 MHz		0.52		dB
		1.80 GHz		0.33		dB
		2.01 GHz		0.38		dB
		2.60 GHz		0.48	0.70	dB
3.50 GHz		0.47	0.70	dB		
Insertion loss, ANT to RX ports	IL <sub>ANT-RX</sub>	V <sub>PIN_2</sub> = 1 V, V <sub>PIN_14</sub> = 28 V, I <sub>PIN_7</sub> = -133 mA, V <sub>PIN_9</sub> = 28 V, ANT port P <sub>IN</sub> @ pin 2 = 0 dBm:				
		900 MHz		0.56		dB
		1.80 GHz		0.26		dB
		2.01 GHz		0.29		dB
		2.60 GHz		0.34	0.50	dB
3.50 GHz		0.36	0.50	dB		
Isolation, TX to RX ports	ISO <sub>TX-RX</sub>	V <sub>PIN_2</sub> = 1 V, I <sub>PIN_14</sub> = -100 mA, I <sub>PIN_9</sub> = -100 mA, V <sub>PIN_7</sub> = 28 V, TX port P <sub>IN</sub> @ pin 14 = 0 dBm:				
		900 MHz		34		dB
		1.80 GHz		37		dB
		2.01 GHz		39		dB
		2.60 GHz	40	50		dB
3.50 GHz	31	34		dB		
Isolation, ANT to TX ports	ISO <sub>ANT-TX</sub>	V <sub>PIN_2</sub> = 1 V, V <sub>PIN_14</sub> = 28 V, I <sub>PIN_7</sub> = -133 mA, V <sub>PIN_9</sub> = 28 V, ANT port P <sub>IN</sub> @ pin 2 = 0 dBm:				
		900 MHz		35		dB
		1.80 GHz		30		dB
		2.01 GHz		29		dB
		2.60 GHz	25	28		dB
3.50 GHz	22	25		dB		
Isolation, ANT to RX ports	ISO <sub>ANT-RX</sub>	V <sub>PIN_2</sub> = 2 V, I <sub>PIN_14</sub> = -100 mA, I <sub>PIN_9</sub> = -100 mA, V <sub>PIN_7</sub> = 28 V, ANT port P <sub>IN</sub> @ pin 2 = 0 dBm:				
		900 MHz		33		dB
		1.8 to 2.1 GHz	36	37		dB
		2.3 to 2.7 GHz	37	43		dB
		2.6 GHz	40	44		dB
3.5 GHz	30	33		dB		
Input return loss		1.8 to 3.5 GHz:				
		RX insertion loss state, ANT port (@ pin 2)		25		dB
		TX insertion loss state, TX port (@ pin 14)		20		dB

**Table 4. SKY12210-478LF Electrical Specifications<sup>1</sup> (2 of 2)**  
**(TOP = +25 °C, Characteristic Impedance [Z<sub>0</sub>] = 50 Ω, EVB Optimized for 2.6 GHz Operation, Unless Otherwise Noted)**

Parameter	Symbol	Test Condition	Min	Typical	Max	Units
Transmit 2 <sup>nd</sup> harmonic	2fo	TX insertion loss state, TX port P <sub>IN</sub> @ pin 14 = +30 dBm: 900 MHz 1.80 GHz 2.01 GHz 2.60 GHz 3.50 GHz		-88 -85 -95 -95 -89		dBc dBc dBc dBc dBc
Transmit 3 <sup>rd</sup> harmonic	3fo	TX insertion loss state, TX port P <sub>IN</sub> @ pin 14 = +30 dBm: 900 MHz 1.80 GHz 2.01 GHz 2.60 GHz 3.50 GHz		-99 -97 -105 -97 -90		dBc dBc dBc dBc dBc
Transmit third order input intercept point	IIP3	V <sub>PIN_2</sub> = 2 V, I <sub>PIN_14</sub> = -100 mA, I <sub>PIN_9</sub> = -100 mA, V <sub>PIN_7</sub> = 28 V, TX port P <sub>IN</sub> @ pin 14 = +30 dBm/tone, tone spacing = 1 MHz: @ 2.6 GHz		+78		dBm
Transmit 0.1 dB input compression point	IPO.1dB	V <sub>PIN_2</sub> = 2 V, I <sub>PIN_14</sub> = -100 mA, I <sub>PIN_9</sub> = -100 mA, V <sub>PIN_7</sub> = 28 V: @ 1.8 to 2.6 GHz		+49		dBm
Receive 0.1 dB input compression point	IPO.1dB	V <sub>PIN_2</sub> = 1 V, V <sub>PIN_14</sub> = 28 V, I <sub>PIN_7</sub> = -133 mA, V <sub>PIN_9</sub> = 28 V: @ 1.8 to 2.6 GHz		+46		dBm
Maximum transmit CW input power	P <sub>IN_CW</sub>	V <sub>PIN_2</sub> = 2 V, I <sub>PIN_14</sub> = -100 mA, I <sub>PIN_9</sub> = -100 mA, V <sub>PIN_7</sub> = 28 V: @ 0.9 to 3.5 GHz		100		W
Maximum receive CW input power	P <sub>IN_CW</sub>	V <sub>PIN_2</sub> = 1 V, V <sub>PIN_14</sub> = 28 V, I <sub>PIN_7</sub> = -133 mA, V <sub>PIN_9</sub> = 28 V: @ 0.9 to 3.5 GHz		40		W
Transmit RF switching time	t <sub>sw</sub>	10% to 90% RF on, repetition rate = 0.1 MHz, @ 2.60 GHz		157		ns
Thermal resistance (junction to case)	Θ <sub>JC</sub>			14		°C/W

<sup>1</sup> Performance is guaranteed only under the conditions listed in this table.

### Typical Performance Characteristics

(TOP = +25 °C, Characteristic Impedance [Zo] = 50 Ω, EVB Optimized for 2.6 GHz Operation, Bias = 28 V/100 mA, Unless Otherwise Noted)

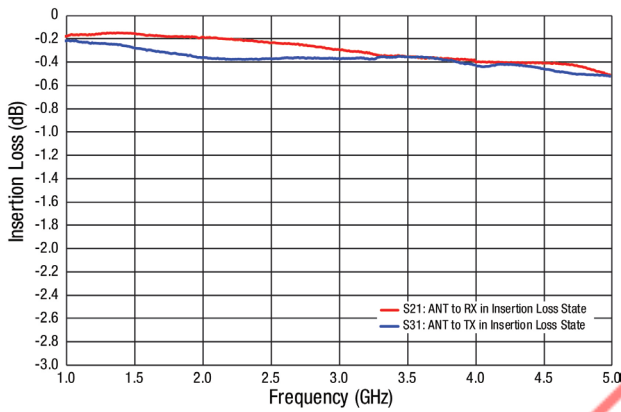

Figure 3. Insertion Loss vs Frequency

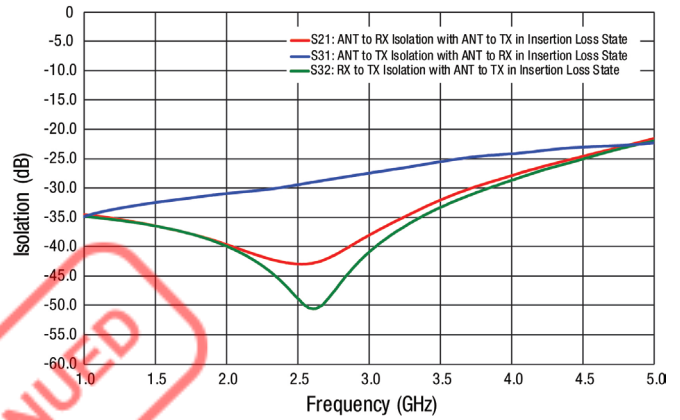

Figure 4. Isolation vs Frequency

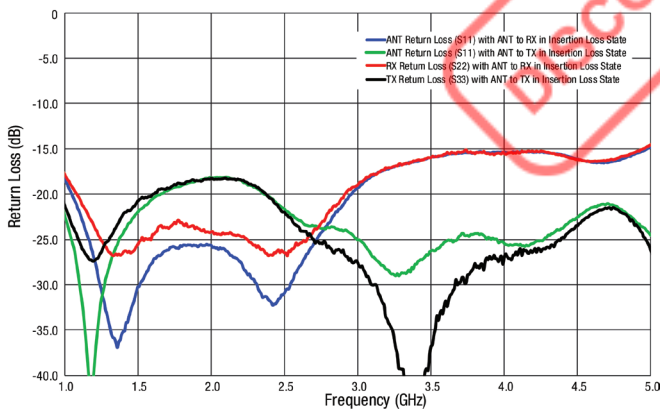

Figure 5. Return Loss vs Frequency

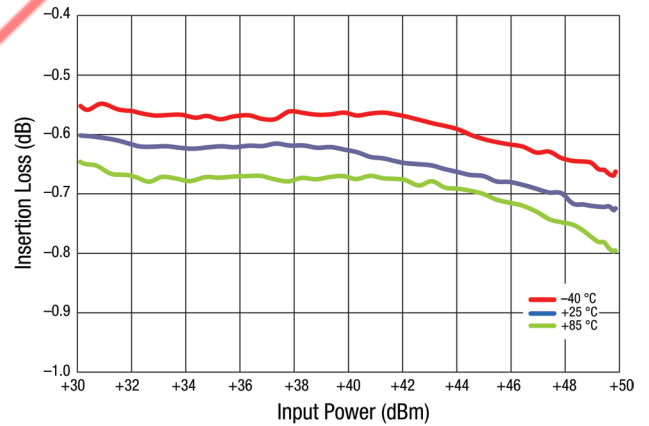

Figure 6. Insertion Loss vs CW Input Power (TX to ANT Port, f = 2600 MHz, 28 V, 100 mA, EVB Loss Included)

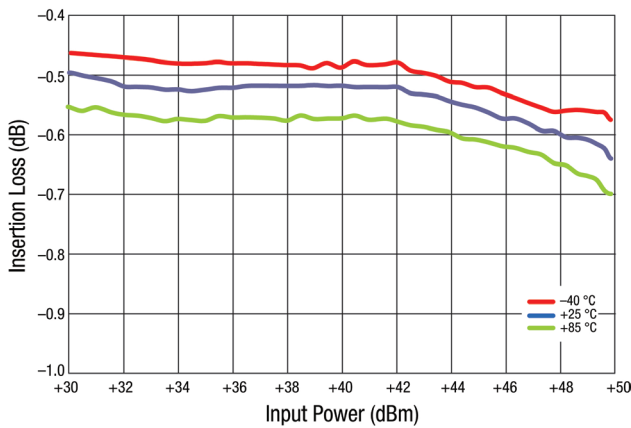

Figure 7. Insertion Loss vs CW Input Power (TX to ANT Port, f = 2300 MHz, 28 V, 100 mA, EVB Loss Included)

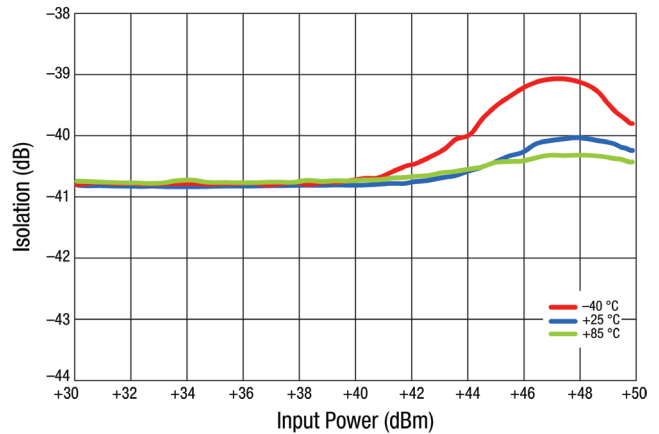
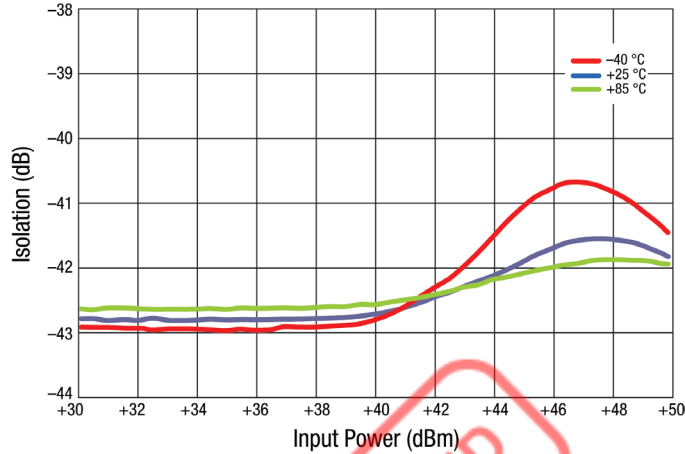

Figure 8. Isolation vs CW Input Power (ANT to RX Port, f = 2300 MHz, 28 V, 100 mA, EVB Loss Included)



**Figure 9. Isolation vs CW Input Power**  
**(ANT to RX Port, f = 2600 MHz, 28 V, 100 mA, EVB Loss Included)**

**Table 5. SKY12210-478LF Truth Table**

Switch State	Path		Control Conditions			
	Antenna-to-Receiver Port (Pin 2 to Pin 7)	Transmitter-to-Antenna Port (Pin 14 to Pin 2)	Antenna Port Bias Input (Pin 2)	Nominal Receiver Output Port (Pin 7)	Nominal Transmitter Port Bias Input (Pin 14)	RX_BIAS Input (Pin 9)
Receive (see Figure 12)	Low insertion loss	High isolation	1 V	-133 mA	28 V	28 V
Transmit (see Figure 12)	High isolation	Low insertion loss	2 V	28 V	-100 mA	-100 mA

**Table 6. SKY12210-478LF Evaluation Board Truth Table**

Switch State	Path		Control Conditions			
	Antenna-to-Receiver Port	Transmitter-to-Antenna Port	Antenna Port Bias Input	Receiver Output Port	Transmitter Port Bias Input	RX_BIAS Input
Receive (see Figure 12)	Low insertion loss	High isolation	5 V	0 V (ground)	28 V	28 V
Transmit (see Figure 12)	High isolation	Low insertion loss	5 V	28 V	0 V (ground)	0 V (ground)

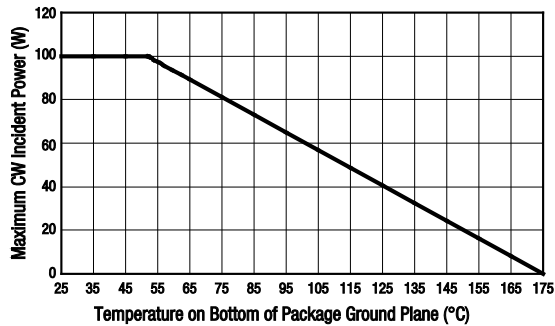

Figure 10. Transmit Power Derating, Maximum CW Incident Power (Frequency = 2.6 GHz) vs Ground Plane Temperature

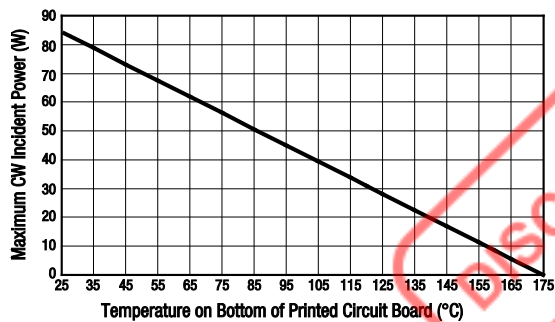

Figure 11. Transmit Power De-Rating, Maximum CW Incident Power (Frequency = 2.6 GHz) vs Printed Circuit Board Temperature

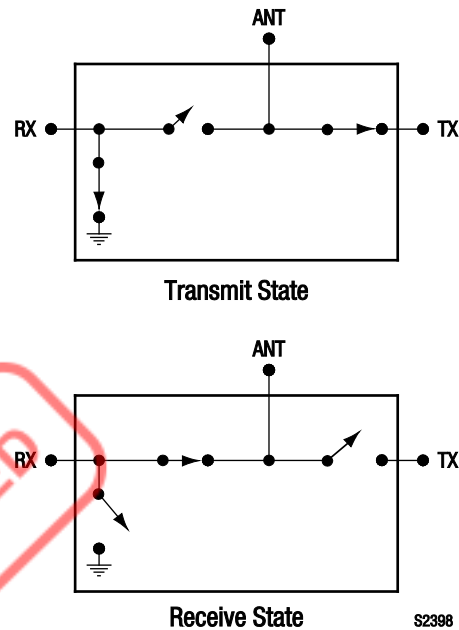

Figure 12. SKY12210-478LF Equivalent Circuit Diagrams

### Evaluation Board Description

The SKY12210-478LF Evaluation Board is used to test the performance of the SKY12210-478LF PIN Diode SPDT switch. An assembly drawing for the Evaluation Board is shown in Figure 13. The layer detail physical characteristics are provided in Figure 14.

The SKY12210-478LF is designed to handle very large signals. Sufficient power may be dissipated by this switch to cause heating of the PIN diodes contained in the switch. It is very important to use a printed circuit board design that provides adequate cooling capability to keep the junction temperature of the PIN diodes below their maximum rated operating temperature.

As indicated in Figure 10, the x-axis temperature is referenced to the bottom of the QFN package. A printed circuit board with a very low thermal resistance and external heat sink design must be used to achieve the results shown in this Figure. The power derating curve with the x-axis temperature referenced to the bottom of the printed circuit board is provided in Figure 11.

The evaluation circuit is designed to facilitate control of the SKY12210-478LF transmit/receive switch with bias signals derived from positive voltages. The state of the PIN diodes within the SKY12210-478LF is controlled with 5 V applied to the ANT port and bias voltages of either 28 V or 0 V applied to the

remaining bias inputs (RX and TX ports). The switch state circuit diagrams are shown in Figure 12.

The value of resistor R1, 31 Ω, is selected to provide 100 mA of forward current through the "on" series diode with 5 V applied to the ANT port bias pin. The R2 resistance value of 262 Ω is selected to produce approximately 100 mA of forward bias current in the RX shunt diode with a source voltage of 28 V.

The magnitudes of the voltages applied to the TX and RX ports determine which of the RX or TX series diodes is biased into forward conduction. For example, to place the SKY12210-478LF into the transmit state, 0 V is applied to the TX port (which forward biases the diode between pins 2 and 14), 28 V is applied to the RX port (which reverse biases the diode between pins 2 and 7), and 0 V is applied to the RX\_BIAS port (which applies a forward bias through R2 to the diode connected between pins 7 and 9).



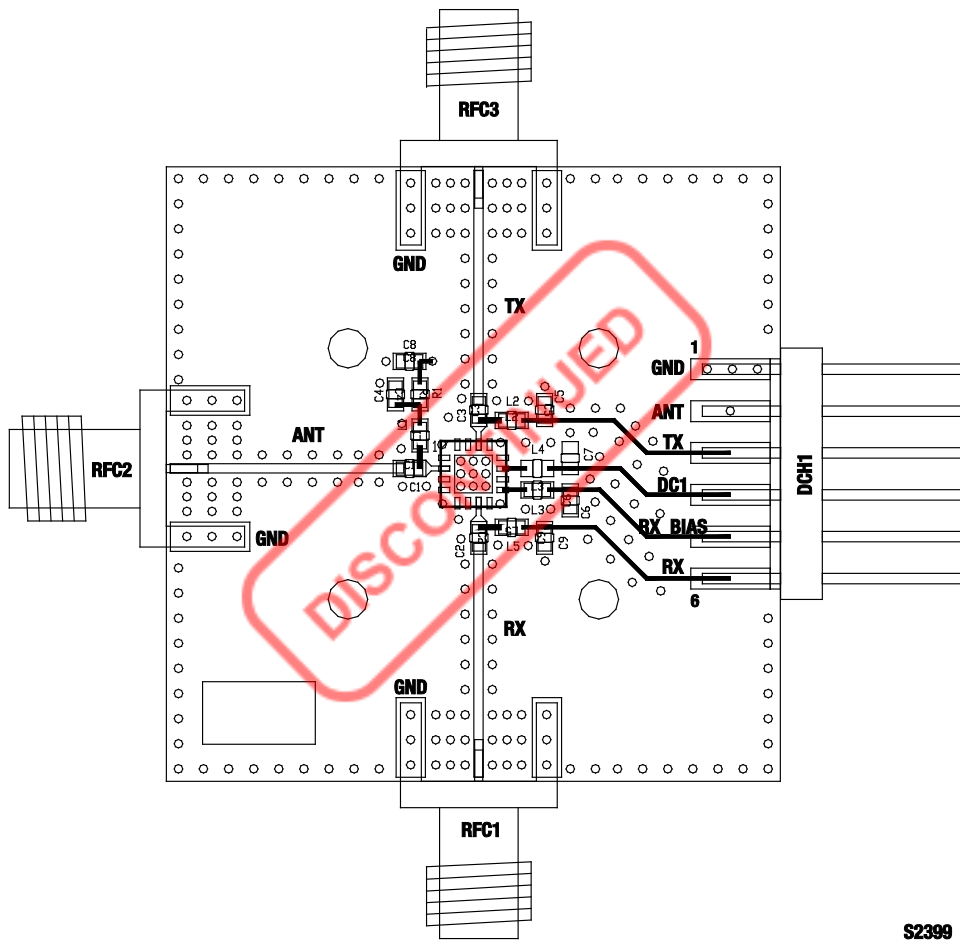

The component values shown in the Evaluation Board circuit diagram (Figure 15) were selected to optimize performance in the 2.0 to 3.5 GHz band.

Refer to Table 7 for the Evaluation Board Bill of Materials. Table 8 provides voltage, current, and resistor values for bias adjustments.



S2399

Figure 13. SKY12210-478LF Evaluation Board Assembly Diagram

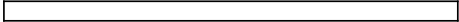
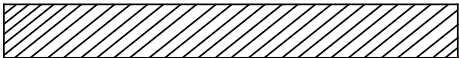
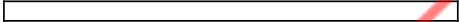
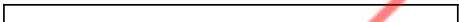
Cross Section	Name	Thickness (in)	Material
	Top Soldermask		
	L1	(0.0028)	Cu foil
	Laminate	0.012 ± 0.0006	Rogers R04003C Core
	L2	(0.0014)	Cu foil
	Laminate	(Note 1)	FR4 Prepreg
	L3	(0.0014)	Cu foil
	Laminate	0.010 ± 0.0006	FR4 Core
	L4	(0.0028)	Cu foil
	Bottom Soldermask		

Note 1: Adjust this thickness to meet total thickness goal of 0.062 ± 0.005 inches.

S2531

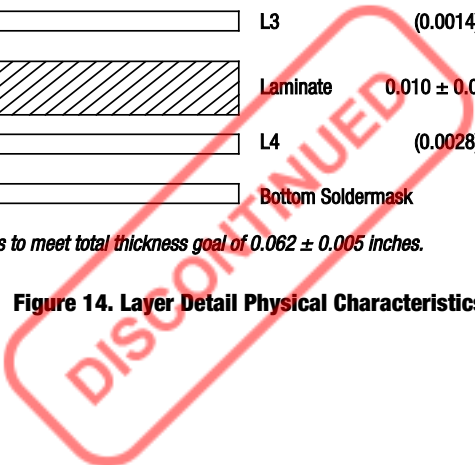
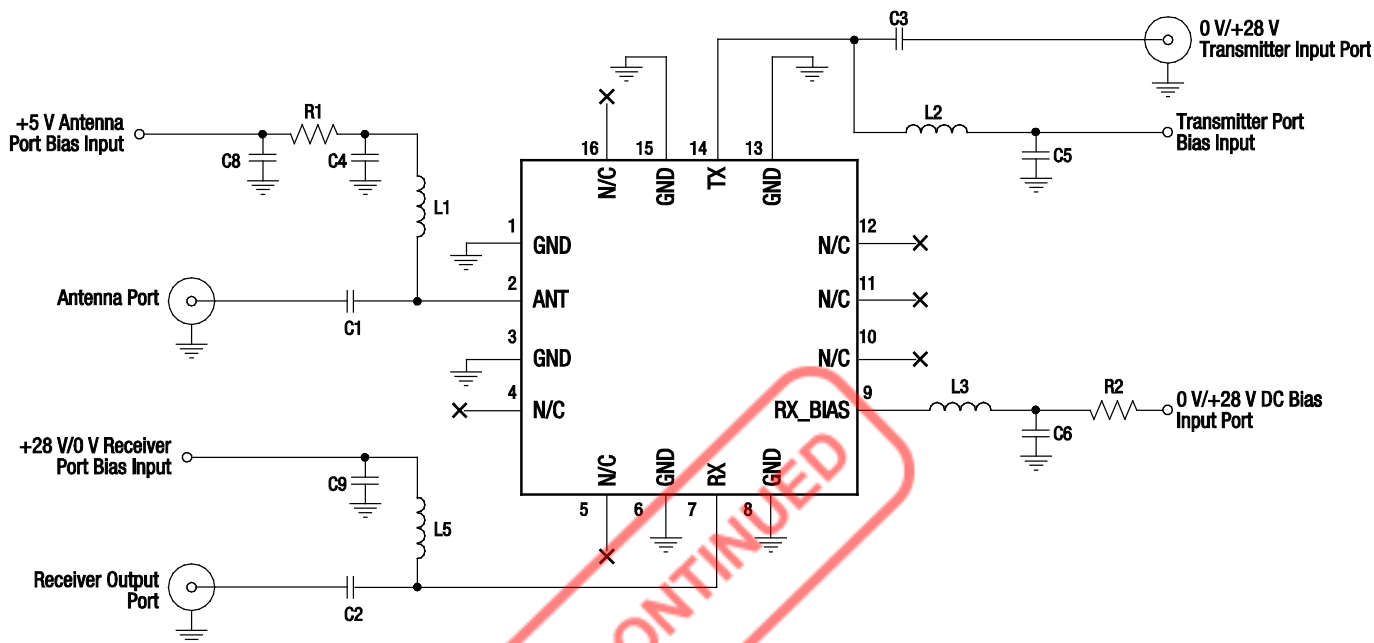

Figure 14. Layer Detail Physical Characteristics



**NOTE:** The N/C pins (4, 5, 10, 11, 12, and 16) are not internally connected, so they can be left open or grounded.

S2402

**Figure 15. Evaluation Board Schematic**

**Table 7. Evaluation Board Bill of Materials<sup>1</sup>**

Component	Value	Size	Manufacturer	Mfr Part Number	Characteristics
C1, C2, C3, C4, C5, C6, C9	1000 pF	0603	TDK	C1608C0G1H102JT	COG, 50 V, ±5%
C8	1 μF	0603	TDK	C2012X7R1H104K	X7R, 50 V, ±10%
L1	22 nH	0603	muRata	LQW18AN20NJ00	High Q inductor, ±5%
L2, L5	47 nH	0603	muRata	LQW18AN47NJ00	High Q inductor, ±5%
L3	560 nH	0603	Coil Craft	0603LS-561XJLB	SRF, 525 MHz, ±5%
R1 <sup>2</sup>	62 Ω	0603	Panasonic	ERJ-3GEYJ620V	0.2 W, ±5%
R2 <sup>3</sup>	262 Ω	-	-	-	Axial leaded (off board)

<sup>1</sup> Component values selected are based on the desired frequency and bias level. Values may be adjusted for a specific response.

<sup>2</sup> Two 62 Ω resistors are combined in parallel to achieve a minimum power handling requirement and 31 Ω resistance.

<sup>3</sup> Evaluation Board does not include resistor R2. Operating at 28 V and 100 mA requires resistor R2 with a power dissipation greater than 2.7 W.

**Table 8. Component Calculation Values**

Vs (V)	V <sub>DIODE</sub> (V)	V <sub>RES</sub> (V)	Current (A)	Resistance (Ω)	Power Dissipation (W)
28	1	27	0.10	262	2.7
5	2	3	0.10	30	0.3

**Notes:** Vs = supply voltage; V<sub>DIODE</sub> = voltage drop across the diode; V<sub>RES</sub> = voltage drop across the resistor.

R1 and R2 values are calculated by (Vs - V<sub>DIODE</sub>)/I, where I is the desired bias current.

The power dissipation in R1 or R2 is calculated by I x (Vs - V<sub>DIODE</sub>). The resistor selected must be safely rated with a power greater than the dissipated power.

### Package Dimensions

The PCB layout footprint for the SKY12210-478LF is shown in Figure 16. Typical part markings are noted in Figure 17. Package dimensions are shown in Figure 18, and tape and reel dimensions are provided in Figure 19.

### Package and Handling Information

Instructions on the shipping container label regarding exposure to moisture after the container seal is broken must be followed. Otherwise, problems related to moisture absorption may occur when the part is subjected to high temperature during solder assembly.

The SKY12210-478LF is rated to Moisture Sensitivity Level 1 (MSL1) at 260 °C. It can be used for lead or lead-free soldering. For additional information, refer to the Skyworks Application Note, *Solder Reflow Information*, document number 200164.

Care must be taken when attaching this product, whether it is done manually or in a production solder reflow environment. Production quantities of this product are shipped in a standard tape and reel format.

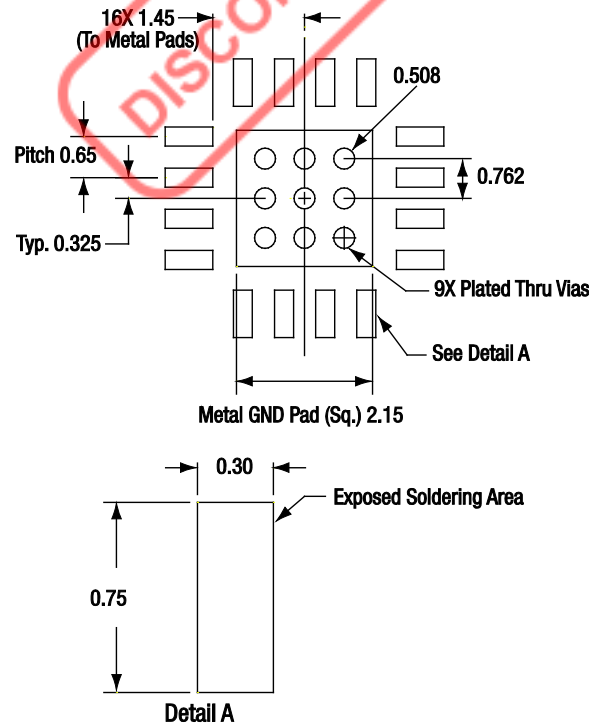

All measurements in millimeters

S2274

Figure 16. SKY12210-478LF PCB Layout Footprint

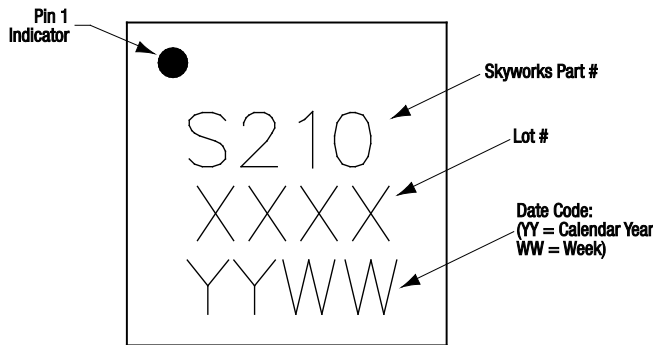
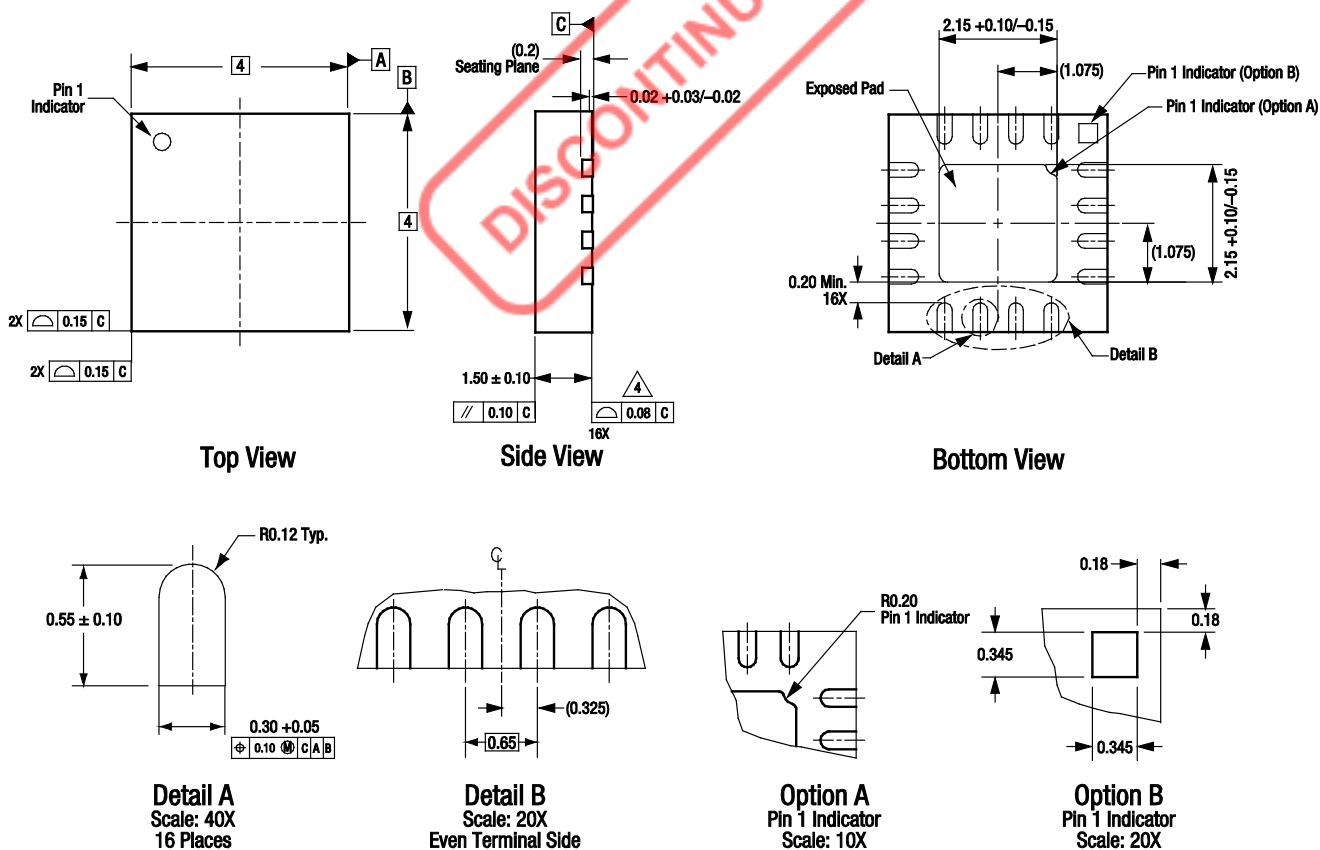

Figure 17. Typical Part Markings



All measurements are in millimeters.  
Dimensioning and tolerancing according to ASMEY14.5M-1994.  
Coplanarity applies to the exposed heat sink slug as well as the terminals.  
Package may have option A or option B pin 1 indicator.

S2400a

Figure 18. SKY12210-478LF Package Dimensions

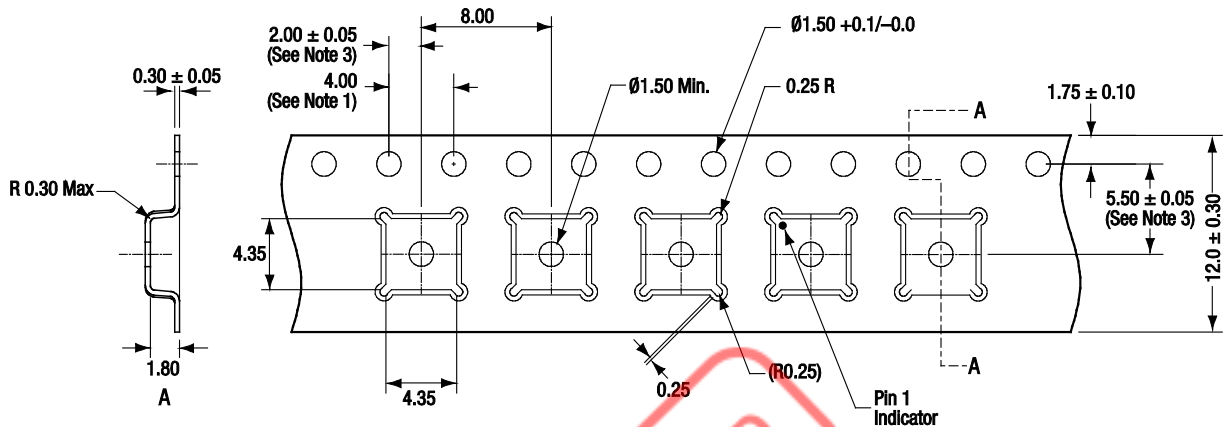

Notes:

1. Sprocket hole pitch cumulative tolerance:  $\pm 0.2$  mm
2. Carrier tape: black conductive polystyrene.
3. Pocket position relative to sprocket hole, measure as true position of pocket, not pocket hole.
4. Cover tape material: transparent conductive adhesive.
5. ESD surface resistivity must meet all ESD requirements of Skyworks, specified in GPO1-D232.
6. All dimensions are in millimeters.

S2817

Figure 19. SKY12210-478LF Tape and Reel Dimensions

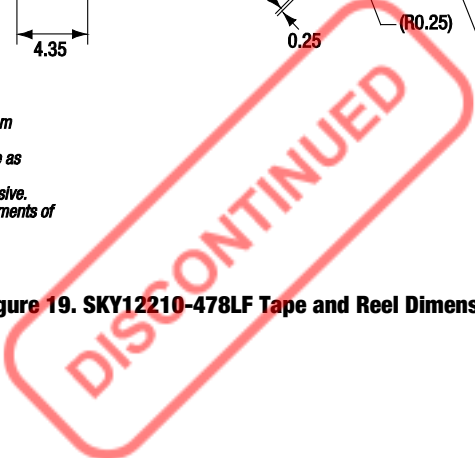

## Ordering Information

Part Number	Product Description	Evaluation Board Part Number
SKY12210-478LF	PIN Diode SPDT Switch	SKY12210-478LF-EVB



Copyright © 2011-2015, 2020, 2026, Skyworks Solutions, Inc. All Rights Reserved.

Information in this document is provided in connection with Skyworks Solutions, Inc., and its subsidiaries (“Skyworks”) products or services. These materials, including the information contained herein, are provided by Skyworks as a service to its customers and may be used for informational purposes only by the customer. Skyworks assumes no responsibility for errors or omissions in these materials or the information contained herein. Skyworks may change its documentation, products, services, specifications or product descriptions at any time, without notice. Skyworks makes no commitment to update the materials or information and shall have no responsibility whatsoever for conflicts, incompatibilities, or other difficulties arising from any future changes.

No license, whether express, implied, by estoppel or otherwise, is granted to any intellectual property rights by this document. Skyworks assumes no liability for any materials, products or information provided hereunder, including the sale, distribution, reproduction or use of Skyworks products, information or materials, except as may be provided in Skyworks’ Terms and Conditions of Sale.

THE INFORMATION IN THIS DOCUMENT AND THE MATERIALS AND PRODUCTS DESCRIBED THEREIN ARE PROVIDED “AS IS” WITHOUT WARRANTY OF ANY KIND, WHETHER EXPRESS, IMPLIED, STATUTORY, OR OTHERWISE, INCLUDING FITNESS FOR A PARTICULAR PURPOSE OR USE, MERCHANTABILITY, PERFORMANCE, QUALITY OR NON-INFRINGEMENT OF ANY INTELLECTUAL PROPERTY RIGHT; ALL SUCH WARRANTIES ARE HEREBY EXPRESSLY DISCLAIMED. SKYWORKS DOES NOT WARRANT THE ACCURACY OR COMPLETENESS OF THE INFORMATION, TEXT, GRAPHICS OR OTHER ITEMS CONTAINED WITHIN THESE MATERIALS. SKYWORKS SHALL NOT BE LIABLE FOR ANY DAMAGES, INCLUDING BUT NOT LIMITED TO ANY SPECIAL, INDIRECT, INCIDENTAL, STATUTORY, OR CONSEQUENTIAL DAMAGES, INCLUDING WITHOUT LIMITATION, LOST REVENUES OR LOST PROFITS THAT MAY RESULT FROM THE USE OF THE MATERIALS OR INFORMATION, WHETHER OR NOT THE RECIPIENT OF MATERIALS HAS BEEN ADVISED OF THE POSSIBILITY OF SUCH DAMAGE.

Skyworks products are not designed, intended, authorized, or warranted for use or inclusion in life support or life endangering applications, devices, or systems where failure or inaccuracy might cause death or personal injury. Skyworks customers agree not to use or sell the Skyworks products for such applications, and further agree to, without limitation, fully defend, indemnify, and hold harmless Skyworks and its agents from and against any and all actions, suits, proceedings, costs, expenses, damages, and liabilities including attorneys’ fees arising out of or in connection with such improper use or sale.

Skyworks assumes no liability for applications assistance, customer product design, or damage to any equipment resulting from the use of Skyworks products outside of Skyworks’ published specifications or parameters. Customers are solely responsible for their products and applications using the Skyworks products.

“Skyworks” and the Skyworks Starburst logo are registered trademarks of Skyworks Solutions, Inc., in the United States and other countries. Third-party brands and names are for identification purposes only and are the property of their respective owners. Additional information, including relevant terms and conditions, posted at [www.skyworksinc.com](http://www.skyworksinc.com), are incorporated by reference.