

DATA SHEET

SKY13431-374LF: 0.5 to 6.0 GHz SPDT Switch, 50 Ω Terminated

Applications

- Dual-band WLANs (802.11 a/b/g/n)
- WLAN 802.11a/c for video distribution
- LTE/4G systems
- WiMAX 802.16

Features

- 50 Ω matched RF ports in all states
- Low insertion loss: 0.5 dB @ 2.5 GHz
- High isolation: 25 dB @ 2.5 GHz
- IP1dB: +36 dBm
- Small DFN (6-pin, 1.5 x 1.5 mm) package (MSL1, 260 °C per JEDEC J-STD-020)
- For RoHS and other product compliance information, see the [Skyworks Certificate of Conformance](#)

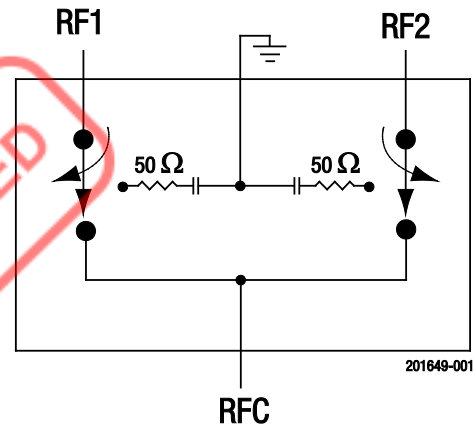

Figure 1. SKY13431-374LF Block Diagram

Description

The SKY13431-374LF is a GaAs pHEMT single-pole, double-throw (SPDT) high-power switch with 50 Ω terminated outputs. The high-linearity performance and low insertion loss achieved by the SKY13431-374LF make it an ideal choice for WiMAX and higher power WLAN applications such as access points.

This part is designed for use in WLAN systems using discrete power amplifier (PA) and low-noise amplifier (LNA) implementations. The 50 Ω impedance of the switch in the “off” state ensures good isolation regardless of the match to which the switch is connected.

The SKY13431-374LF is manufactured in a compact, 1.5 x 1.5 mm, 6-pin Dual Flat No-Lead (DFN) package.

A functional block diagram is shown in Figure 1. The pin configuration and package are shown in Figure 2. Signal pin assignments and functional pin descriptions are provided in Table 1.

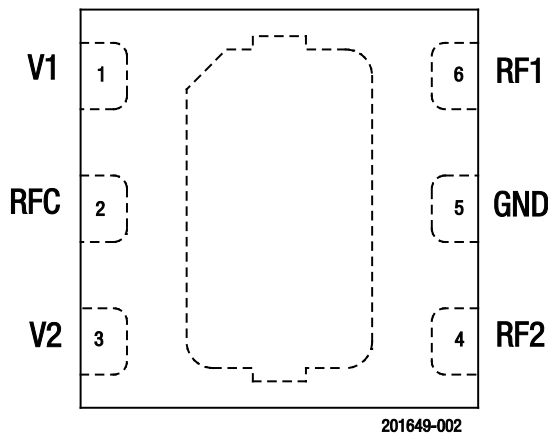

Figure 2. SKY13431-374LF Pinout (Top View)

Table 1. SKY13431-374LF Signal Descriptions

Pin	Name	Description	Pin	Name	Description
1	V1	DC control voltage. A logic high voltage enables an insertion loss path between the RFC and RF1 pins.	4	RF2	RF output: 50 Ω terminated when in isolation state. Must be DC blocked.
2	RFC	RF common input. Must be DC blocked.	5	GND	Ground
3	V2	DC control voltage. A logic high voltage enables an insertion loss path between the RFC and RF2 pins.	6	RF1	RF output: 50 Ω terminated when in isolation state. Must be DC blocked.

Functional Description

Switching is controlled by two control voltage inputs, V1 and V2 (pins 1 and 3, respectively). Depending on the logic voltage level applied to the control pins, the RFC pin is connected to one of the two switched RF outputs, RF1 or RF2, using a low insertion loss path, while the path between the RFC pin and the other RF pin is in a high isolation state.

DC blocking capacitors are required on all RF ports of the switch. The value of the capacitors determines the low frequency operation. The isolated RF output is internally terminated to 50 Ω. The return loss of the isolated port is limited in frequency by on-chip capacitors.

Electrical and Mechanical Specifications

The absolute maximum ratings of the SKY13431-374LF are provided in Table 2. Electrical specifications are provided in Table 3.

Typical performance characteristics of the SKY13431-374LF are illustrated in Figures 3 through 6.

The state of the SKY13431-374LF is determined by the logic provided in Table 4.

Table 2. SKY13431-374LF Absolute Maximum Ratings¹

Parameter	Symbol	Minimum	Maximum	Units
Control voltage	V _{CTL}		6	V
Input power	P _{IN}		+37	dBm
Storage temperature	T _{STG}	-40	+125	°C
Operating temperature	T _{OP}	-40	+85	°C

¹ Exposure to maximum rating conditions for extended periods may reduce device reliability. There is no damage to device with only one parameter set at the limit and all other parameters set at or below their nominal value. Exceeding any of the limits listed here may result in permanent damage to the device.

ESD HANDLING: *Although this device is designed to be as robust as possible, electrostatic discharge (ESD) can damage this device. This device must be protected at all times from ESD when handling or transporting. Static charges may easily produce potentials of several kilovolts on the human body or equipment, which can discharge without detection. Industry-standard ESD handling precautions should be used at all times.*

Table 3. SKY13431-374LF Electrical Specifications¹**($V_{CTL} = 0\text{ V}$ and $+3.0\text{ V}$, $T_{OP} = +25\text{ }^{\circ}\text{C}$, $P_{IN} = 0\text{ dBm}$, Characteristic Impedance [Z_0] = $50\text{ }\Omega$, $C_{BLK} = 47\text{ pF}$, Unless Otherwise Noted)**

Parameter	Symbol	Test Condition	Min	Typical	Max	Units
RF Specifications						
Insertion loss	IL	RFC to RF1 or RF2:				
		0.50 to 2.70 GHz		0.50	0.80	dB
		2.70 to 3.80 GHz		0.60	0.95	dB
		3.80 to 5.85 GHz		0.80	1.30	dB
Isolation	Iso	RFC to RF1 or RF2:				
		0.50 to 2.70 GHz	23	25	29	dB
		2.70 to 3.80 GHz	20	23		dB
		3.80 to 5.85 GHz	17	20		dB
Input return loss ("on" state)	IS11l	RFC or RF1 or RF2, 0.5 to 6.0 GHz		17.5		dB
Output return loss ("off" state)	IS22l	Isolated output RF1 or RF2:				
		2.30 to 2.70 GHz		11		dB
		2.70 to 3.80 GHz		11		dB
		3.80 to 5.85 GHz		11		dB
1 dB input compression point	IP1dB	$V_{CTL} = 3.0\text{ V}$:				
		2.30 to 2.70 GHz		+36		dBm
		3.30 to 3.80 GHz		+36		dBm
		4.90 to 5.85 GHz		+36		dBm
Third order input intercept point	IIP3	$P_{IN} = +25\text{ dBm/ tone}$, $\Delta F = 1\text{ MHz}$, $V_{CTL} = 3.0\text{ V}$:				
		2.4 GHz		58		dB
		3.8 GHz		58		dB
		5.8 GHz		57		dB
2 nd harmonic	2fo	$P_{IN} = +25\text{ dBm}$, $V_{CTL} = 3.0\text{ V}$:				
		0.9 GHz		78		dBc
		1.8 GHz		78		dBc
		2.4 GHz		81		dBc
		3.8 GHz		82		dBc
		5.8 GHz		75		dBc
3 rd harmonic	3fo	$P_{IN} = +25\text{ dBm}$, $V_{CTL} = 3.0\text{ V}$:				
		0.9 GHz		76		dBc
		1.8 GHz		76		dBc
		2.4 GHz		72		dBc
		3.8 GHz		68		dBc
		5.8 GHz		75		dBc
Switching speed		50% V_{CTL} to 90/10% RF		100	250	ns
DC Specifications						
Control voltage	V_{CTL}		2.5	3.0	5.0	V
Control current	I_{CC}			5		μA

¹ Performance is guaranteed only under the conditions listed in this table.

Typical Performance Characteristics

(V_{CTL} = 0 V and +3.0 V, T_{OP} = +25 °C, P_{IN} = 0 dBm, Characteristic Impedance [Z₀] = 50 Ω, C_{BLK} = 47 pF, Unless Otherwise Noted)

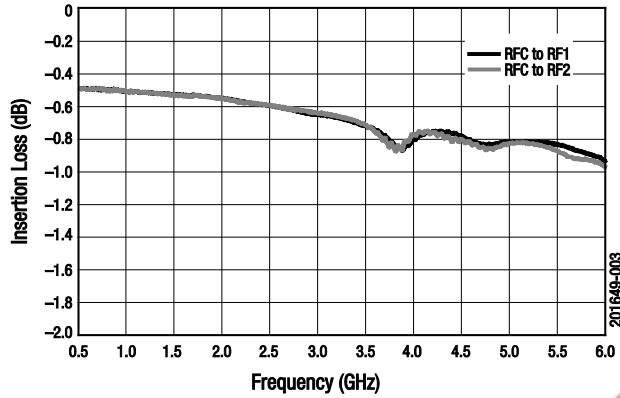

Figure 3. Typical Insertion Loss vs Frequency

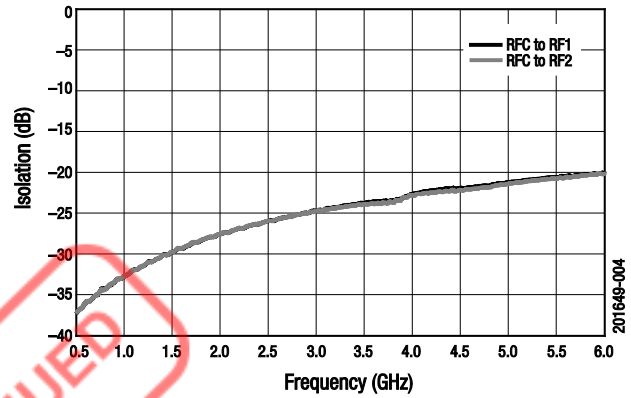

Figure 4. Typical Isolation vs Frequency

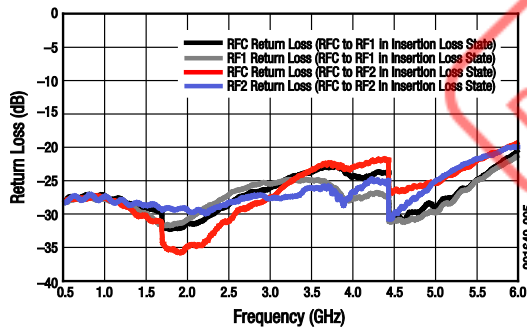

Figure 5. Return Loss vs Frequency (Insertion Loss State)

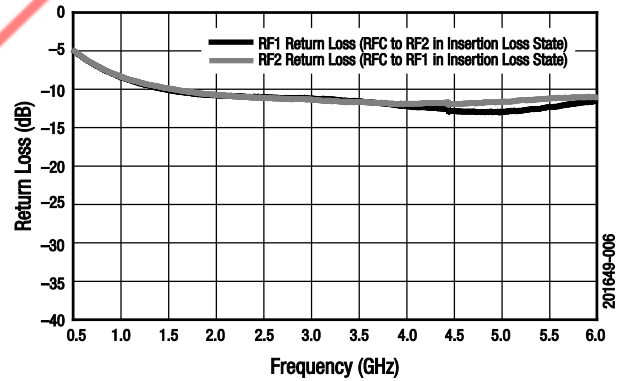

Figure 6. Return Loss vs Frequency (Isolation State)

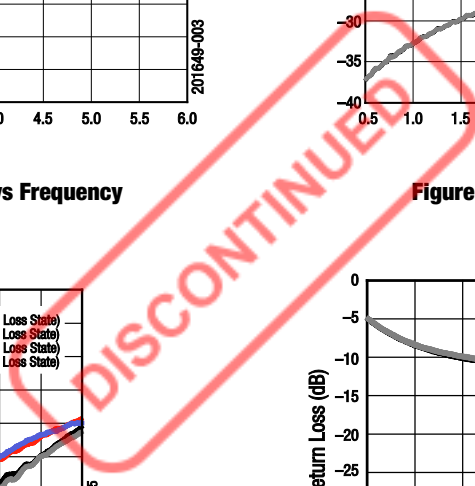

Table 4. SKY13431-374LF Truth Table¹

V1 (Pin 1)	V2 (Pin 3)	Insertion Loss State
1	0	RFC to RF1
0	1	RFC to RF2

¹ "1" = +2.5 V to +5.0 V. "0" = 0 V to +0.2 V. Any state other than described in this table places the switch into an undefined state. An undefined state will not damage the device.

Evaluation Board Description

The SKY13431-374LF Evaluation Board is used to test the performance of the SKY13431-374LF SPDT Switch. An Evaluation Board schematic diagram is provided in Figure 7. An assembly drawing for the Evaluation Board is shown in Figure 8.

Package Dimensions

The PCB layout footprint for the SKY13431-374LF is provided in Figure 9. Typical case markings are shown in Figure 10. Package dimensions are shown in Figure 11, and tape and reel dimensions are provided in Figure 12.

Package and Handling Information

Instructions on the shipping container label regarding exposure to moisture after the container seal is broken must be followed. Otherwise, problems related to moisture absorption may occur when the part is subjected to high temperature during solder assembly.

The SKY13431-374LF is rated to Moisture Sensitivity Level 1 (MSL1) at 260 °C. It can be used for lead or lead-free soldering. For additional information, refer to the Skyworks Application Note, *Solder Reflow Information*, document number 200164.

Care must be taken when attaching this product, whether it is done manually or in a production solder reflow environment. Production quantities of this product are shipped in a standard tape and reel format.

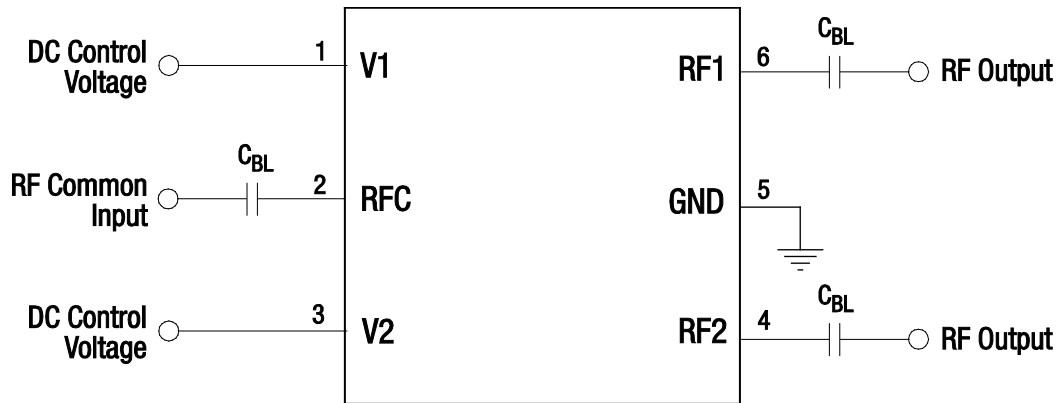

C_{BL} = 47 pF for >1 GHz operation. Increase value for lower frequency operation.

Exposed ground paddle should be grounded for best performance.

201649-007

Figure 7. SKY13431-374LF Evaluation Board Schematic

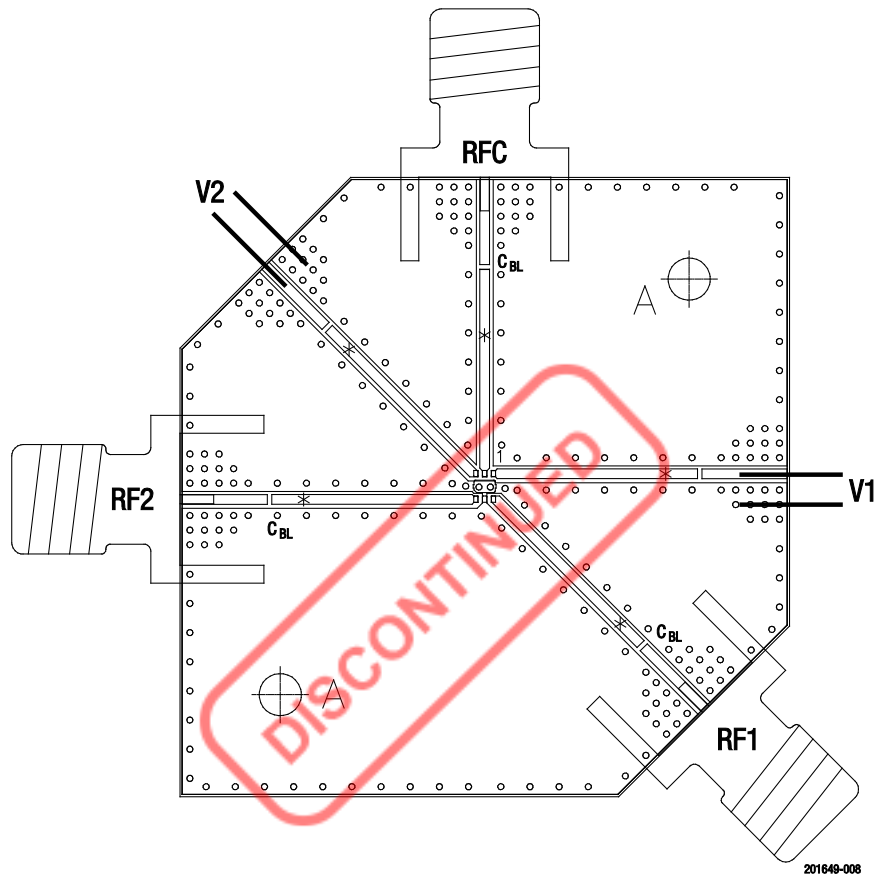

Figure 8. SKY13431-374LF Evaluation Board Assembly Diagram

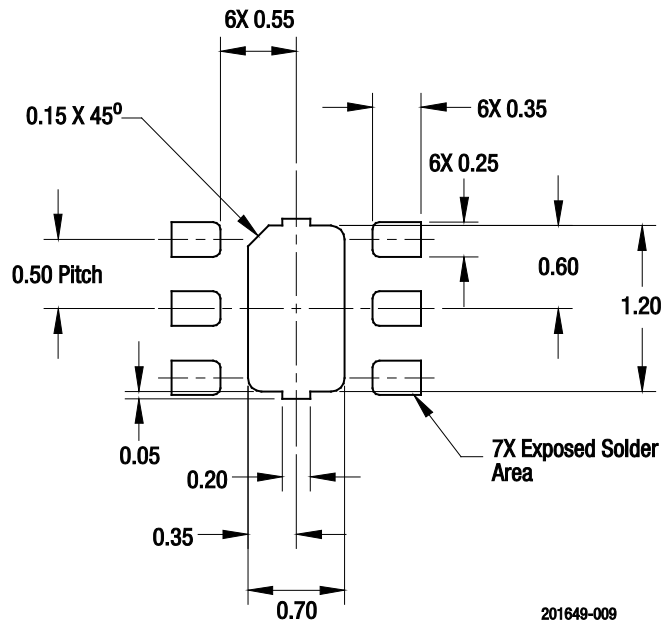

Figure 9. SKY13431-374LF PCB Layout Footprint (Top View)

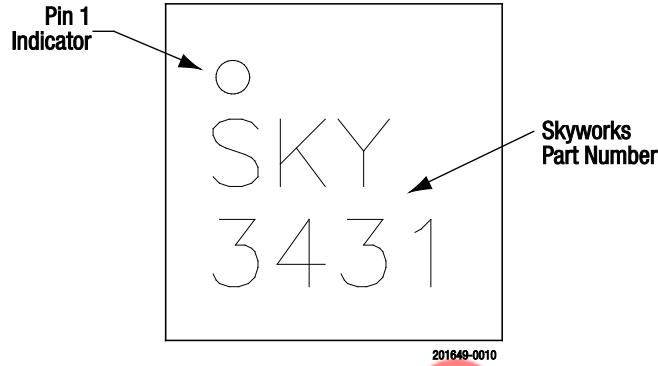
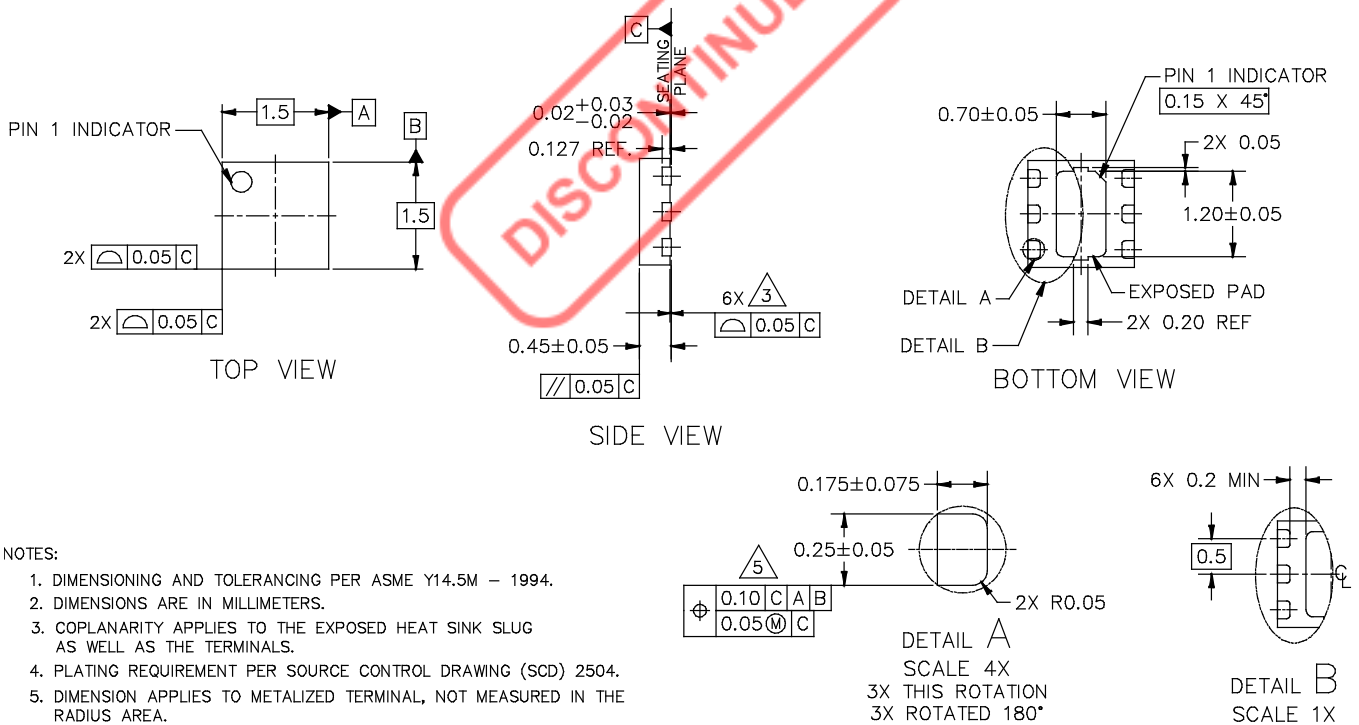

Figure 10. Typical Part Markings (Top View)



NOTES:

1. DIMENSIONING AND TOLERANCING PER ASME Y14.5M – 1994.
2. DIMENSIONS ARE IN MILLIMETERS.
3. COPLANARITY APPLIES TO THE EXPOSED HEAT SINK SLUG AS WELL AS THE TERMINALS.
4. PLATING REQUIREMENT PER SOURCE CONTROL DRAWING (SCD) 2504.
5. DIMENSION APPLIES TO METALIZED TERMINAL, NOT MEASURED IN THE RADIUS AREA.

201649-011

Figure 11. SKY13431-374LF DFN Package Dimensions

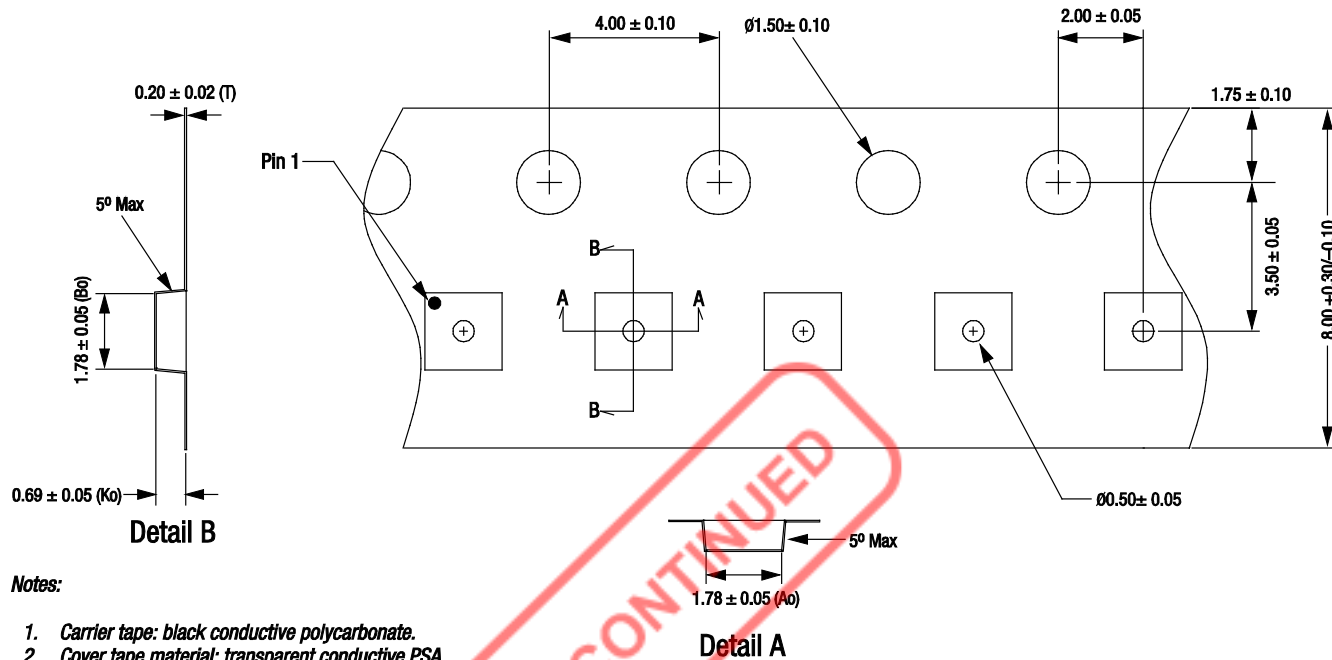

Notes:

1. Carrier tape: black conductive polycarbonate.
2. Cover tape material: transparent conductive PSA.
3. Cover tape size: 5.4 mm width.
4. All measurements are in millimeters.
5. ESD surface resistivity is $\leq 1 \times 10^8$ Ohms/square per EIA, JEDEC tape and reel specification.

201649-012

Figure 12. SKY13431-374LF Tape and Reel Dimensions

Ordering Information

Product Description	Product Part Number	Evaluation Board Part Number
SKY13431-374LF: SPDT Switch	SKY13431-374LF	SKY13431-374LF-EVB



Copyright © 2011, 2012, 2013, 2018, 2026, Skyworks Solutions, Inc. All Rights Reserved.

Information in this document is provided in connection with Skyworks Solutions, Inc., and its subsidiaries ("Skyworks") products or services. These materials, including the information contained herein, are provided by Skyworks as a service to its customers and may be used for informational purposes only by the customer. Skyworks assumes no responsibility for errors or omissions in these materials or the information contained herein. Skyworks may change its documentation, products, services, specifications or product descriptions at any time, without notice. Skyworks makes no commitment to update the materials or information and shall have no responsibility whatsoever for conflicts, incompatibilities, or other difficulties arising from any future changes.

No license, whether express, implied, by estoppel or otherwise, is granted to any intellectual property rights by this document. Skyworks assumes no liability for any materials, products or information provided hereunder, including the sale, distribution, reproduction or use of Skyworks products, information or materials, except as may be provided in Skyworks' Terms and Conditions of Sale.

THE INFORMATION IN THIS DOCUMENT AND THE MATERIALS AND PRODUCTS DESCRIBED THEREIN ARE PROVIDED "AS IS" WITHOUT WARRANTY OF ANY KIND, WHETHER EXPRESS, IMPLIED, STATUTORY, OR OTHERWISE, INCLUDING FITNESS FOR A PARTICULAR PURPOSE OR USE, MERCHANTABILITY, PERFORMANCE, QUALITY OR NON-INFRINGEMENT OF ANY INTELLECTUAL PROPERTY RIGHT; ALL SUCH WARRANTIES ARE HEREBY EXPRESSLY DISCLAIMED. SKYWORKS DOES NOT WARRANT THE ACCURACY OR COMPLETENESS OF THE INFORMATION, TEXT, GRAPHICS OR OTHER ITEMS CONTAINED WITHIN THESE MATERIALS. SKYWORKS SHALL NOT BE LIABLE FOR ANY DAMAGES, INCLUDING BUT NOT LIMITED TO ANY SPECIAL, INDIRECT, INCIDENTAL, STATUTORY, OR CONSEQUENTIAL DAMAGES, INCLUDING WITHOUT LIMITATION, LOST REVENUES OR LOST PROFITS THAT MAY RESULT FROM THE USE OF THE MATERIALS OR INFORMATION, WHETHER OR NOT THE RECIPIENT OF MATERIALS HAS BEEN ADVISED OF THE POSSIBILITY OF SUCH DAMAGE.

Skyworks products are not designed, intended, authorized, or warranted for use or inclusion in life support or life endangering applications, devices, or systems where failure or inaccuracy might cause death or personal injury. Skyworks customers agree not to use or sell the Skyworks products for such applications, and further agree to, without limitation, fully defend, indemnify, and hold harmless Skyworks and its agents from and against any and all actions, suits, proceedings, costs, expenses, damages, and liabilities including attorneys' fees arising out of or in connection with such improper use or sale.

Skyworks assumes no liability for applications assistance, customer product design, or damage to any equipment resulting from the use of Skyworks products outside of Skyworks' published specifications or parameters. Customers are solely responsible for their products and applications using the Skyworks products.

"Skyworks" and the Skyworks Starburst logo are registered trademarks of Skyworks Solutions, Inc., in the United States and other countries. Third-party brands and names are for identification purposes only and are the property of their respective owners. Additional information, including relevant terms and conditions, posted at www.skyworksinc.com, are incorporated by reference.