



SKYWORKS®

PRODUCT SUMMARY

SKY68040-11: Multi-mode, Multi-band Power Amplifier Module for Cat M1/NB-IOT and NTN

Applications

- LTE Cat-M1, Cat NB-IOT
- 5G IOT Non-Terrestrial-Networks (NTN)
- Universal modem products:
 - Low-band: 5, 8, 12, 13, 14, 17, 18, 19, 20, 26, 28, 71, 85
 - Mid-band: 1, 2, 3, 4, 24, 25, 39, 66, 70
- NTN L-Band (B24, n255)+ S-Band (B23, B256)

Features

- Low-voltage supply for NB-IOT application: 2.8 V to 4.2 V
- High efficiency:
 - 48% at maximum power output
- Large dynamic range
- Small, low profile package
 - 3.0 mm x 4.2 mm x 0.86 mm nom.
 - 14-pad configuration
- Power-down control
- InGaP
- Supports low-voltage VCC operation
- Digital enable
- No VREF required
- CMOS compatible control signals
- Integrated directional coupler
- For RoHS and other product compliance information, see the [Skyworks Certificate of Conformance](#).

Description

The SKY68040-11 is a multiband Power Amplifier Module (PAM) supporting LTE Cat-M1, Cat1 NB-IOT and 5G IOT NTN transceiver.

The module integrates an LTE multiband radio operating in low-band (5, 8, 12, 13, 14, 17, 18, 19, 20, 26, 28, 71, 85), mid-band (1, 2, 3, 4, 24, 25, 39, 66, 70) frequencies and NTN L-Band (B24, n255) + S-Band (B23, B256), including broadband PAs with bias/gain controller. A directional coupler integrated into the module eliminates the need for an external coupler.

The single Gallium Arsenide (GaAs) Microwave Monolithic Integrated Circuit (MMIC) contains all active circuitry in the module. The MMIC contains onboard bias circuitry, as well as input and interstage matching circuits. Output match into a 50 ohm load is realized off-chip within the module package to optimize efficiency and power performance.

The SKY68040-11 PAM is manufactured with the Skyworks InGaP GaAs Heterojunction Bipolar Transistor (HBT) process. This provides for all positive voltage dc supply operation while maintaining high efficiency and good linearity.

No VREF voltage is required. Power down is accomplished by setting the voltage on VENHB and VENLB to zero volts. No external supply side switch is needed as typical “off” leakage is a few microamperes with full primary voltage supplied from the battery.

Block Diagram

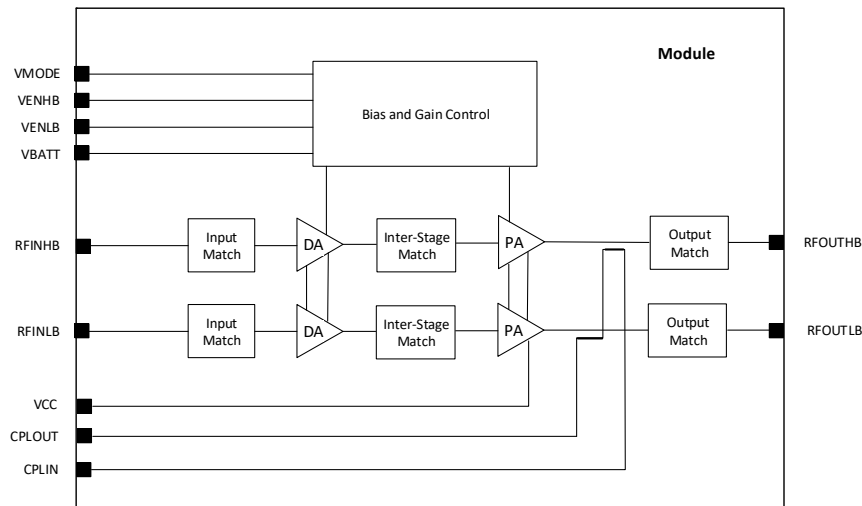

Figure 1. Functional Block Diagram

Ordering Information

Part Number	Description	Evaluation Board Part Number
SKY68040-11	Multi-Mode, Multi-Band Power Amplifier Module for Cat M1/NB-IOT and NTN	SKY68040-11EK1

Copyright © 2024-2025 Skyworks Solutions, Inc. All Rights Reserved.

Information in this document is provided in connection with Skyworks Solutions, Inc., and its subsidiaries (“Skyworks”) products or services. These materials, including the information contained herein, are provided by Skyworks as a service to its customers and may be used for informational purposes only by the customer. Skyworks assumes no responsibility for errors or omissions in these materials or the information contained herein. Skyworks may change its documentation, products, services, specifications or product descriptions at any time, without notice. Skyworks makes no commitment to update the materials or information and shall have no responsibility whatsoever for conflicts, incompatibilities, or other difficulties arising from any future changes.

No license, whether express, implied, by estoppel or otherwise, is granted to any intellectual property rights by this document. Skyworks assumes no liability for any materials, products or information provided hereunder, including the sale, distribution, reproduction or use of Skyworks products, information or materials, except as may be provided in Skyworks’ Terms and Conditions of Sale.

THE INFORMATION IN THIS DOCUMENT AND THE MATERIALS AND PRODUCTS DESCRIBED THEREIN ARE PROVIDED “AS IS” WITHOUT WARRANTY OF ANY KIND, WHETHER EXPRESS, IMPLIED, STATUTORY, OR OTHERWISE, INCLUDING FITNESS FOR A PARTICULAR PURPOSE OR USE, MERCHANTABILITY, PERFORMANCE, QUALITY OR NON-INFRINGEMENT OF ANY INTELLECTUAL PROPERTY RIGHT; ALL SUCH WARRANTIES ARE HEREBY EXPRESSLY DISCLAIMED. SKYWORKS DOES NOT WARRANT THE ACCURACY OR COMPLETENESS OF THE INFORMATION, TEXT, GRAPHICS OR OTHER ITEMS CONTAINED WITHIN THESE MATERIALS. SKYWORKS SHALL NOT BE LIABLE FOR ANY DAMAGES, INCLUDING BUT NOT LIMITED TO ANY SPECIAL, INDIRECT, INCIDENTAL, STATUTORY, OR CONSEQUENTIAL DAMAGES, INCLUDING WITHOUT LIMITATION, LOST REVENUES OR LOST PROFITS THAT MAY RESULT FROM THE USE OF THE MATERIALS OR INFORMATION, WHETHER OR NOT THE RECIPIENT OF MATERIALS HAS BEEN ADVISED OF THE POSSIBILITY OF SUCH DAMAGE.

Skyworks products are not designed, intended, authorized, or warranted for use or inclusion in life support or life endangering applications, devices, or systems where failure or inaccuracy might cause death or personal injury. Skyworks customers agree not to use or sell the Skyworks products for such applications, and further agree to, without limitation, fully defend, indemnify, and hold harmless Skyworks and its agents from and against any and all actions, suits, proceedings, costs, expenses, damages, and liabilities including attorneys’ fees arising out of or in connection with such improper use or sale.

Skyworks assumes no liability for applications assistance, customer product design, or damage to any equipment resulting from the use of Skyworks products outside of Skyworks’ published specifications or parameters. Customers are solely responsible for their products and applications using the Skyworks products.

“Skyworks” and the Skyworks Starburst logo are registered trademarks of Skyworks Solutions, Inc., in the United States and other countries. Third-party brands and names are for identification purposes only and are the property of their respective owners. Additional information, including relevant terms and conditions, posted at www.skyworksin.com, are incorporated by reference.