

AN1167: Safety Considerations for Skyworks Series Capacitive Isolators

Isolators are widely used in automotive, telecom, industrial, and medical applications to provide protection for people and/or equipment from high voltage hazards. The robustness of the isolator's insulation, or "isolation barrier", over the operating life of the equipment is key to ensuring safety against electric shock in these applications. Various threats, such as lightning strike surges, ESD, overvoltage, over temperature, and age can cause degradation or "breakdown" of the isolator's insulation. It is important that equipment designers understand the possible failure mechanisms for isolators, as well as the requirements set forth in the relevant equipment and component safety standards. This helps designers select the appropriate isolator device for the intended application and ensure that the device is operated within safe limits.

This Application Note begins with a brief overview of isolator technologies, followed by an overview of some of the relevant safety standards and the associated requirements. This is followed by a brief description of some of the many tests that are performed to ensure that Skyworks isolators meet their specified ratings.

The next section describes the series-capacitor-based isolation architecture, pioneered and introduced by Skyworks in 2009. This is followed with a presentation of destructive fault testing that demonstrates "single-fault" and "double-fault" failure modes in these parts. This final section shows that, while all isolators "fail short" after insulation breakdown due to applied voltage in excess of their rated maximum isolation voltage ratings, Skyworks isolators reduce the likelihood of insulation breakdown because of their excellent isolation performance. Furthermore, Skyworks' series capacitor isolation technology is demonstrated to "fail open" for "single fault" events where thermal or electrical overstress results in damage to only one of the two series capacitor dice.

KEY POINTS

- Modern Isolated Technologies
- Safety Standards
- Isolator Failures and Safety Considerations
- Common Isolator Tests and Measurements

1. Overview of Modern Isolator Technologies

1.1 What is an Isolator?

Isolators are electronic devices that allow the transfer of signals or power between two circuits, or two power domains, while preventing current from flowing between the circuits. The diagram below illustrates this concept. In this diagram, Circuit A and Circuit B may be operating at very different supply voltages, and Ground A and Ground B may be at very different potentials, but these circuits are able to pass signals across a high impedance “isolation barrier” using an isolator. The isolation barrier is made up of some form of “insulator” that provides “galvanic isolation” (prevents the flow of direct current) between the circuits. The isolator device passes signals or power across the isolation barrier insulator using techniques such as optical “coupling” (using light energy), magnetic “coupling” (using a magnetic field), or capacitive “coupling” (using an electric field). Isolators may also (understandably) be referred to as “couplers”.

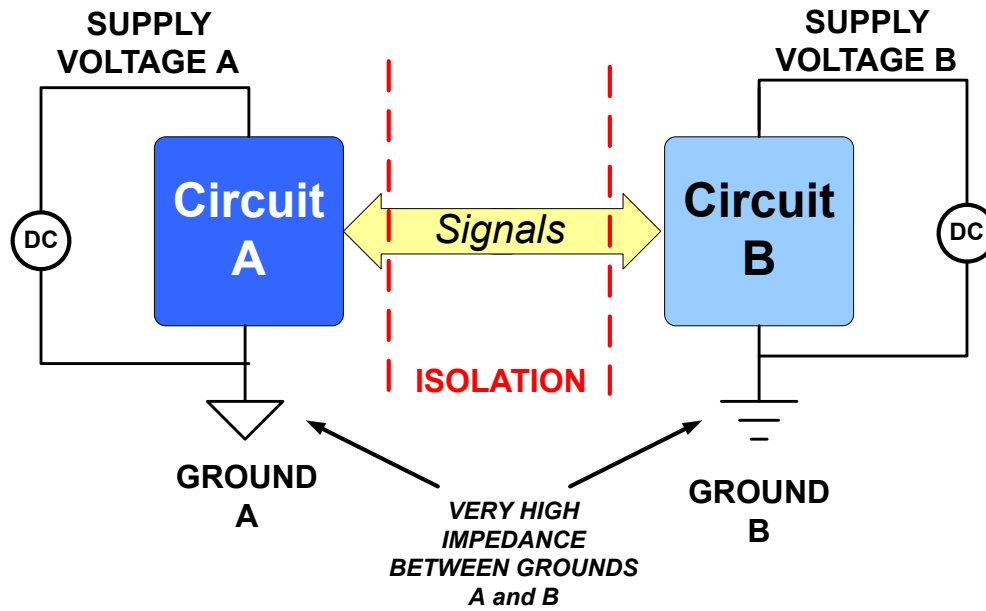

Figure 1.1. Isolation between Circuits

1.2 The Need for Isolation

Isolators are used in many different applications and for many different reasons. Isolators may be used to eliminate “ground loops” by isolating the common ground connection between circuits, thus reducing electrical noise and/or electromagnetic interference (see figure below). Isolators may also be used for “level shifting”, allowing circuits operating at very different supply voltages to communicate.

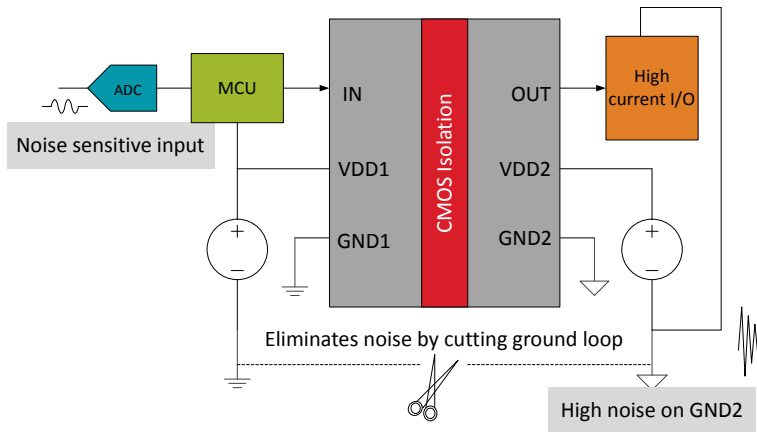

Figure 1.2. Isolators can Reduce Noise/EMI by Eliminating Ground Loops

But the most common use of isolators is to provide “protection” for low voltage circuits or human operators on one side of the isolation barrier from potentially hazardous voltages that may be present on the other side of the barrier, as depicted in the figure below.

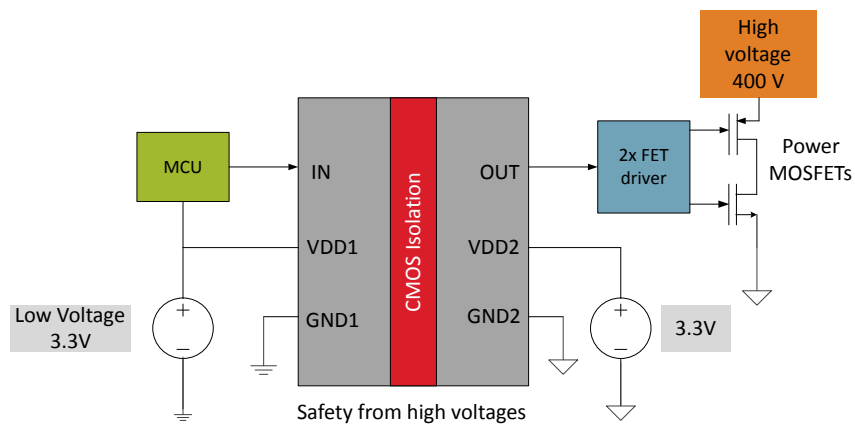

Figure 1.3. Isolators can Provide Safety from High Voltages

1.3 Optical, Magnetic, and Capacitor-based Isolators

Signal or power transmission across an isolation barrier is typically accomplished using optical coupling, magnetic coupling, or capacitive coupling. For isolated transfer of high power levels, such as needed in power supply design, transformers (magnetic coupling) are commonly used. For isolated transfer of low power signals, optical, magnetic, or capacitive isolators are used.

Optical isolators, commonly referred to as optocouplers, photocouplers, or simply “optos” typically use an LED to transmit light across the insulating barrier, which may include some form of insulating film, to a photo detector on the other side of the barrier. Optical isolators may have high breakdown voltages (can withstand high voltages across the isolation barrier), but generally suffer from relatively high power dissipation, limited operating life, performance degradation with temperature and with aging, poor part-to-part matching, and relatively slow speeds. These are some of the factors contributing to the growing market share for the newer CMOS-based magnetic and capacitive isolator technologies.

Magnetic isolators, or magnetic couplers, incorporate small coils on either side of their isolation barrier, effectively forming a transformer within the device. Pulsed or high frequency alternating currents through the primary side coil create a magnetic field that is coupled across the isolation barrier insulation to the secondary coil, which is followed by a receiver that decodes or demodulates the received signal. Magnetic isolators can generate relatively high levels of electromagnetic interference (EMI), and can also suffer from relatively low radiated immunity.

Capacitive isolators, or capacitive couplers, use CMOS-based capacitors to form an isolation barrier. Capacitive isolators couple RF electric fields across the isolation barrier. Skyworks introduced the isolation architecture using two series capacitors as an isolation barrier in 2009. To minimize EMI, differential signaling is used for signal transmission across the isolation barrier. The figure below depicts the different coupling mechanisms for optical, magnetic, and capacitive isolators. Skyworks isolators provide high withstand voltages, low EMI, high immunity, high reliability, and long operating life. Skyworks offers digital isolators with up to six communication channels, isolated PLC input devices with up to eight isolated channels, and a variety of isolated gate driver devices, all using this advanced series capacitor isolator architecture. For more details on digital isolator benefits, see *“The Benefits of Opto-Coupled and Digital Isolators in Circuit Design Today”*¹.

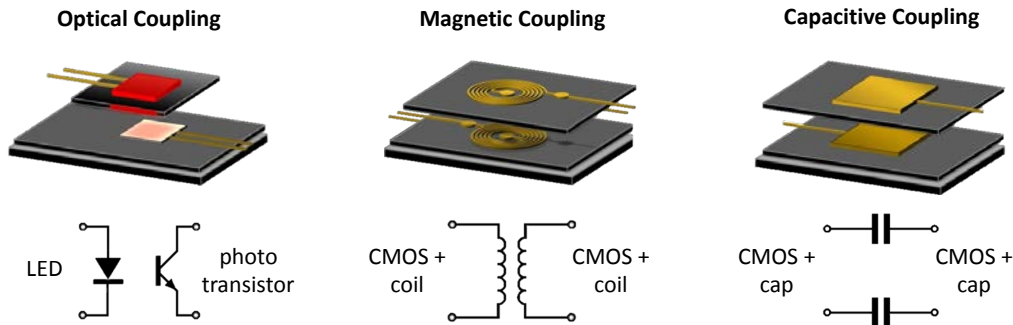

Figure 1.4. Optical, Magnetic, and Capacitive Coupling

2. Safety Standards

Applications that use isolators to provide protection for humans against electric shock merit special consideration, as failure of the isolator to provide the required isolation barrier insulation in these applications may compromise safety and introduce the risk of electric shock. There are several national and international safety standards, both for equipment and for components, which have specific requirements for isolators used in safety-related applications.

Organizations that develop and publish safety-related standards include the IEC (Europe, worldwide), VDE (Germany), UL (USA), CSA (Canada), and SAC (China). Standards developed by one country or agency are often adopted with only minor changes for use in/by other countries/agencies. Some of these standards organizations provide testing and certification services. In other cases, third-party test facilities may be used to test and certify components or equipment to the relevant safety standards. Certification of equipment to the relevant equipment safety standards for a given country is generally required for the sale or use of the equipment in that country. Certification of safety-related components to the associated component safety standards helps ensure that these components meet the relevant safety requirements, and use of pre-certified components can often speed up the equipment certification process. Many Skyworks isolator devices have been pre-certified to various safety standards, and certification documentation is made available to customers.

- The IEC (International Electrotechnical Commission) is an organization that prepares international standards for electrical/electronic equipment. Stakeholders from many nations participate in the IEC. The IEC coordinates with the ISO (International Organization for Standardization) and the ITU (International Telecommunication Union) to ensure that their standards work together. The IEC does not provide certification services; certification to IEC standards is done by independent test houses.
- The DKE (German commission for electrical, electronic and information technologies) is a national organization responsible for standards and safety specifications for electronics and information technology in Germany. DKE is a joint organization of DIN (Deutsches Institut für Normung e.V., the German institute for standardization) and VDE (Verband der Elektrotechnik, Elektronik und Informationstechnik e.V. (VDE), an association for electrical, electronic and information technologies). The VDE is responsible for the daily operations of the DKE. Standards developed by the VDE become sanctioned by DKE, and these standards may be adopted by the International Electrotechnical Commission (IEC). VDE also offers testing and certification services.
- UL (formerly known as Underwriters Laboratories) is an organization that provides a wide variety of services, including standards development, testing, and certification of electronic equipment. UL is well known for their safety standards.
- The CSA (Canadian Standards Association) is a Canadian standards development and certification body accredited by the SCC (Standards Council of Canada).
- The SAC (Standardization Administration of China) develops standards in China. Equipment is tested and certified to SAC standards by the CQC (China Quality Certification Centre).

2.1 Equipment Safety Standards

Equipment safety standards provide safety requirements for different classes of equipment.

These can include specific requirements for insulation, creepage and clearance distances (more on this later), testing, and more. Many of the equipment-level safety requirements also apply to the safety-related components, such as isolators, used in the system. In many cases, some of the equipment safety testing requirements may be satisfied using components that have been certified to relevant component safety standards. The following are some of the key equipment safety standards that may be applicable to capacitive isolators used in safety-related applications:

- IEC 62368-1 (UL 62368-1) *ICT and AV Equipment- Part 1 Safety Requirements*. This is an international safety standard that supersedes IEC 60065 *Audio, Video and Similar Electronic Apparatus – Safety Requirements* and IEC 60950 *Information Technology Equipment – Safety*². At the time of this writing, IEC 60065 and IEC 60950 are scheduled to be withdrawn on December 20, 2020.
- IEC 60601-1 *Medical electrical equipment - Part 1: General Requirements for Basic Safety and Essential Performance*³.
- IEC 61010-1 (UL-61010-1) *Safety Requirements for Electrical Equipment for Measurement, Control, and Laboratory Use*⁴.
- SAC GB4943-1, *Information Technology Equipment – Safety, Part 1: General Requirements*⁵. This specification is harmonized with IEC 60950-1 with some specific China requirements.

2.2 Component Safety Standards

Component Safety standards provide safety requirements for different types of safety-related components. The requirements specified in safety standards for isolator components may include testing for lifetime at operating voltage (TDDB), dielectric breakdown (hipot and lightning surge testing), temperature and humidity testing, insulator integrity (withstand voltage, insulation resistance, and partial discharge/apparent charge testing), creepage and clearance distance measurements, and more. Testing requirements are typically broken down into “type tests”, done once to validate/certify a design, and “routine tests” and “sample tests” that are performed on a recurring basis during production.

To expedite the safety approval process for a piece of equipment, the equipment designer may select safety-related components (e.g., optos, digital isolators) that are pre-certified to the relevant component safety standard. This can significantly expedite bringing an equipment design to market, because the corresponding system safety qualification steps, which can take months to complete, can often be skipped when pre-certified components are used.

The following are some of the key component safety standards that may be applicable to capacitive isolators used in safety-related applications:

- IEC 60747-5-5 *Semiconductor Devices - Discrete Devices - Part 5-5: Optoelectronic Devices – Photocouplers*⁶. Although this is a safety standard for optical isolators, the requirements were often also applied to magnetic and capacitive isolators before specific component safety standards were developed for these devices.
- VDE 0884-10 and VDE 0884-11, *Semiconductor Devices – Magnetic and Capacitive Coupler for Basic and Reinforced Isolation*⁷. These standards provide terminology, essential ratings, safety test requirements, and measuring methods for magnetic and capacitive couplers or isolators.
- IEC 60747-17 *Magnetic and Capacitive Coupler for Basic and Reinforced Isolation*⁸. This standard is a work-in-progress with a forecast publication date of 02-Jul-20 at the time of this writing. This safety standard applies specifically to magnetic and capacitive isolators (referred to as “couplers”), using SiO₂ insulation (“SiO₂ isolators”) or thin film polymer insulation (thin film polymer isolators).
- UL 1577 *Standard for Safety, Optical Isolators*⁹. This standard specifies isolation requirements for the insulation between the isolated circuits of optical isolators. Although this standard specifically addresses optical isolators, it is often applied to magnetic and capacitive-based isolators.

2.3 Other Related Standards

Many other standards may be referenced as normative parts of the equipment and/or component safety standards. Some relevant examples include:

- IEC 60060-1, *High-Voltage Test Techniques - Part 1: General Definitions and Test Requirements*¹⁰.
- IEC 60664-1, *Insulation Coordination for Equipment within Low-Voltage Systems - Part 1: Principles, Requirements and Tests*¹¹.
- IEC 62539 (IEEE 930), *Guide for the Statistical Analysis of Electrical Insulation Breakdown Data*¹².

3. What Causes Isolators to Fail, and How Do We Ensure Safety?

There are several different conditions that could potentially lead to an isolator device's failure to provide safety from electrical shock. These include insulation breakdown due to excessive voltage applied across the isolation barrier, insulation degradation due to aging, insulation damage due to excessive temperature/environmental conditions, or arcing between metal conductors exposed on the outside of the package. Both equipment safety standards and component safety standards specify a comprehensive set of requirements and test methodologies to ensure that isolators used in safety applications perform as intended in the application. Requirements and test methodologies for isolators may include isolation working voltage, isolation withstand voltage, isolation repetitive peak withstand voltage, isolation transient withstand voltage, isolation surge withstand voltage, partial discharge testing to verify insulation integrity, time dependent dielectric breakdown testing to determine the operating life/working voltage relationship, and more.

Safety standards help ensure that the safety-related specifications and ratings for isolators are well defined, and certification of isolator devices to these standards helps ensure that the devices meet their safety-related specifications and ratings. It is important that designers understand the requirements and associated terminology in order to select isolation devices with the appropriate capabilities and ratings for their equipment/application. It is also critical that designers understand the safety limits specified for the selected components, and ensure that the components are operated within these limits. This section will examine some of the key safety-related specifications and test requirements for isolators used in safety-related applications, using the UL-1577 and IEC 60747-17 component safety standards for many of the examples.

Note that testing of an isolator's insulation characteristics is typically performed with all pins on each side of the isolation barrier tied together, effectively forming a 2-pin device with the isolation barrier insulation between these two pins.

3.1 Common Terminologies

The following terms (or equivalents) are used in many isolator safety standards, such as IEC 60747-17:

Type Tests	A rigorous set of tests used to qualify a new isolator design to some standard. Many of the required tests are destructive. After qualification of the design through type testing, batch sample tests and routine tests are used on a continuing basis during production to ensure that the characteristics of the production devices are consistent with those that were used for type testing.
Batch Sample Tests	Periodic sample-based production tests used to ensure production remains consistent with units that were used for type tests. These tests may be destructive.
Routine Tests	Non-destructive production testing used to ensure production remains consistent with units that were used for type tests.
Functional Insulation	Insulation/isolation required for proper operation of the circuit irrespective of operator safety.
Basic Insulation	Insulation that provides a basic level of protection against shock. A general rule of thumb for isolators is that the device must be able to withstand an applied voltage of 2500 Vrms for 1 minute and must provide an isolation barrier insulation resistance of at least $10^9 \Omega$ to provide basic insulation.
Supplemental Insulation	A second, independent, insulation that is added to Basic insulation to achieve double insulation. Supplemental insulation could be a grounded chassis or a second independent insulation mechanism.
Double Insulation	An insulation system that provides Basic insulation plus an independent “supplemental” insulation that reduces the risk of shock if the Basic insulation fails.
Reinforced Insulation	Insulation that provides a level of protection that is effectively equivalent to double insulation, although it may use a single insulator. A general rule of thumb is isolator that can withstand an applied voltage of 5000 Vrms for 1 minute and provides a $> 10^9 \Omega$ insulation resistance will meet the requirements for reinforced insulation.
Double Protection Optical Isolators	This is a term used in UL-1577 to describe “optical isolators used in some unique applications”, “bridging reinforced insulation”. UL-1577 requires additional testing for this classification of optical isolator. Note that “double protection”, as used in this sense, does not imply “double insulation”.
Maximum Rated Isolation Working Voltage (V_{IOWM})	The long term withstand capability of the isolation in V_{RMS} .
Maximum Rated Repetitive Peak Isolation Voltage (V_{IORM})	The repetitive peak withstand voltage of the isolation (includes repetitive transient voltages but excludes non-repetitive transient voltages).
Maximum Rated Transient Isolation Voltage (V_{IOTM})	<ul style="list-style-type: none"> The peak non-repetitive transient voltage. Applies to internal insulation as well as package clearance. Withstanding isolation voltage V_{ISO}: The maximum isolation a.c.r.m.s. withstanding voltage for one minute.
Maximum Surge Isolation Voltage (V_{IOSM})	The peak voltage of a 1.2/50 us surge waveform that can be applied to the internal insulation (this may be tested in oil to prevent external arcing).
Impulse Voltage (V_{IMP})	The maximum peak impulse voltage with no flash over and no solid insulation breakdown, tested per IEC 60664-1 “Rated impulse voltage for equipment energized directly from the low voltage mains”.
Partial Discharge (pd)	An electrical discharge that only partially bridges the insulation of the isolator.
Apparent Charge (q_{pd})	The amount of discharge in a pd event.
Limiting Values	The operating conditions over which an isolator will function normally.
Safety Limiting Values	Operating conditions which, if exceeded, could cause a failure of the isolator to provide safety against electrical shock. The isolator may not function correctly when operated at the safety limiting values, but it must continue to provide safety against electrical shock.

3.2 UL 1577 Test Requirements Overview

UL 1577 provides qualification test (type test) requirements and manufacturing/production line test requirements for optical isolators. UL1577 type testing includes a dielectric withstand test with environmental preconditioning, an overload test, and a limited thermal aging test.

The dielectric withstand test is performed on 4 sample groups of 6 sample devices each, with different preconditioning for each group; One group is exposed to the device's specified maximum junction temperature for 7 hours before testing, one group is exposed to 85% relative humidity at 32 °C for 24 hours before testing, one group is subject to 0 °C for 24 hours before testing, and one group is tested "as received" (without precondition).

After preconditioning, the dielectric withstand test is performed by ramping the applied voltage up to the device's rated AC or DC dielectric isolation voltage for 60 seconds, and the isolation must not break down.

The overload test subjects a group of 3 sample devices to operation at 150% of the maximum rated output power and 100% of rated input power until temperatures stabilize, after which the devices are subjected to the dielectric withstand test as described above.

The limited thermal aging test exposes three devices to conditioning at elevated temperature for 1000 hours before dielectric withstand testing.

For "double protection optical isolators" (optical isolators used in some unique applications, "bridging reinforced insulation") there is an additional discharge test and an optical isolator life test.

The discharge test exposes ten devices to 50 discharges, at 5 second intervals, from a 0.0005 uF capacitor in a specified RC network charged to 20 kV. After this discharge sequence, the parts must not breakdown when exposed to the greater of their rated isolation voltage or 3500 V_{RMS}, first applied between the input and the output terminals of the device, and then again applied between the combined input and output pins all shorted together, and a metal foil wrapped around the body of the device.

The optical isolator life test exposes ten devices to conditioning at 85 °C for 1008 hours, during which time 440 V_{RMS} is applied between the input and output terminals, with this applied voltage doubled for 1/10 second once each hour. After conditioning, the devices must pass the same breakdown test as used for the discharge test, and must also maintain an isolation resistance of at least 500 MΩ measured at an applied voltage 500 V_{DC}, for 2 minutes.

UL 1577 routine production line testing consists of a dielectric voltage withstand test at the optical isolator's rated AC or DC isolation voltage for 60 seconds.

UL 1577 requires that optical isolators provide maximum power, current and voltage ratings for both the photo-emitter input and the photo-sensor output circuits, along with the dielectric isolation voltage rating, the maximum ambient operating temperature, the maximum junction temperature, and the maximum storage temperature.

3.3 IEC 60747-17 Test Requirements Overview

IEC 60747-17 specifies a rigorous set of type tests that must be performed for initial qualification/certification of new coupler designs. Non-destructive routine production tests and destructive sample tests are specified to ensure that production units continue to provide safety characteristics that are consistent with those of the initial samples used for qualification/certification.

The IEC 60747-17 routine production testing includes an isolation voltage test, and a “method b” (non-destructive) partial discharge test. The sample testing includes a “method a” (destructive) partial discharge test that is performed on a sample basis once per quarter. Descriptions of the isolation voltage test and the partial discharge/apparent charge test are included in the next section of this document.

IEC 60747-17 Type testing involves destructive testing on a total of 552 sample parts, divided into 7 subgroups. Testing for each subgroup is preceded by “preconditioning” which includes visual inspection and measurement of apparent charge (method b1), parametric testing, and measurement of isolation resistance. Descriptions of the isolation voltage test, partial discharge/apparent charge test, TDDB/End of Life - VIORM test, surge test, and creepage and clearance measurements referred to below are included in the next section of this document.

- Subgroup 1 (20 samples) is exposed to various temperature profiles, followed by the apparent charge test (method a), isolation resistance test, surge test, and another (repeated) isolation resistance test.
- Subgroup 2 (15 samples) undergoes temperature change tests, and the input safety test (at safety limiting values, max input power or current) followed by the apparent charge test (method a), isolation resistance test, surge test, and the isolation resistance test.
- Subgroup 3 (15 samples) undergoes temperature change tests, and an output safety test (at safety limiting values, max output power or current) followed by the apparent charge test (method a), isolation resistance test, surge test, and isolation resistance test.
- Subgroup 4 (40 samples) undergoes isolation resistance testing at maximum operating temperature (minimum of 100 °C), and isolation resistance testing at the safety limiting temperature, T_S .
- Subgroup 5 (10 samples) is subject to external creepage and clearance measurements, and to flammability testing.
- Subgroup 6 (432 samples) is used for the “end of life test - V_{IORM} ”. This accelerated life testing, often referred to as time-dependent dielectric breakdown (TDDB) testing, is used to determine the device’s maximum rated repetitive peak isolation voltage, V_{IORM} .
- Subgroup 7 (20 samples) is used for end of life test – V_{IOTM} . In this test, an operating point (applied stress voltage, temperature, and resulting predicted operating life) is selected from the 1 ppm lifetime curve determined by the subgroup 6 end of life test - V_{IORM} testing. The sample parts are then exposed to these conditions for 80% of the predicted operating life, and then tested to ensure that the isolation resistance R_{IO} remains greater than $10^9 \Omega$, measured with 500 V_{DC} applied for 1 minute at 25 °C.

4. Common Isolator Tests and Measurements

4.1 Isolation Resistance Test

Isolation resistance is a measure of the isolation barrier insulation integrity. The resistance is measured with all terminals on side 1 of the isolation barrier connected and all terminals on side 2 connected. For IEC 60747-17 isolation resistance measurements, the voltage applied across the barrier (from side 1 to side 2 of the device) is $500 V_{DC}$. The current through the barrier is measured, and the resistance is calculated as voltage/current. A common requirement is that the isolation resistance be greater than $10^9 \Omega$.

4.2 Isolation Voltage/AC Hipot Test

The IEC 60747-17 isolation voltage test for routine production testing involves ramping the voltage applied across the isolator up to 120% of the maximum rated transient isolation voltage ($1.2 \times V_{IOTM}$) for 1 second. The isolation test during type testing is at V_{IOTM} for 1 minute.

This testing, often referred to as AC hipot (high potential) testing, applies a high-voltage 50/60 Hz sinusoidal signal from side 1 to side 2 (all pins on a given side are shorted together during test). The test signal is typically ramped up from 0 V at a 1 kVrms/sec rate, held at the specified test voltage for 60 seconds, and then ramped back down to 0 V at 1 kVrms/sec.

Note that DC testing is not generally guaranteed by isolator manufacturers, as neither the component nor equipment safety standards require it. However, most manufacturers do test a component's DC performance. The general rule is that a safety component's DC performance is $\sim 1.414x$ its AC performance. However, this is not always the case, as different materials and technology have different breakdown characteristics for AC and DC. If concerned, the designer should ask the manufacturer about the component's DC performance.

4.3 Partial Discharge/Apparent Charge Test

Partial discharge test, also referred to as apparent charge test, is another measure of the isolation barrier's insulation integrity. The test is accomplished by ramping the applied voltage up to a specified "initial test voltage for partial discharge", $V_{pd(ini)}$, for a specified "initial time", t_{ini} , then ramping the voltage down to the "apparent charge measuring voltage", $V_{pd(m)}$, for a specified "partial discharge stress time", t_{st} , during which the apparent charge is measured. The apparent charge must be less than a specified threshold value to pass the test. For IEC60747-17, the values of $V_{pd(ini)}$ and $V_{pd(m)}$ depend on the stage of testing at which the partial discharge or apparent charge test is performed (e.g., routine testing, sample testing, or endurance testing). But in general, $V_{pd(ini)}$ is related to the maximum transient voltage V_{IOTM} , and $V_{pd(m)}$ is related to the maximum repetitive peak isolation voltage V_{IORM} . The apparent charge threshold is 5 pC.

4.4 Surge/Lightning Surge Test

Equipment connected to power mains, earth ground, or other cabling that runs outside of the building can be subject to large voltage surges when nearby lightning strikes occur. To ensure that isolators in safety-related applications continue to provide protection against electrical shock both during and after such surge events, safety standards may require components undergo surge testing using waveforms designed to emulate those that might occur due to lightning strikes. IEC 60747-17 type testing requires surge testing using a standardized “1.2/50 us” surge waveform, as depicted in the figure below.

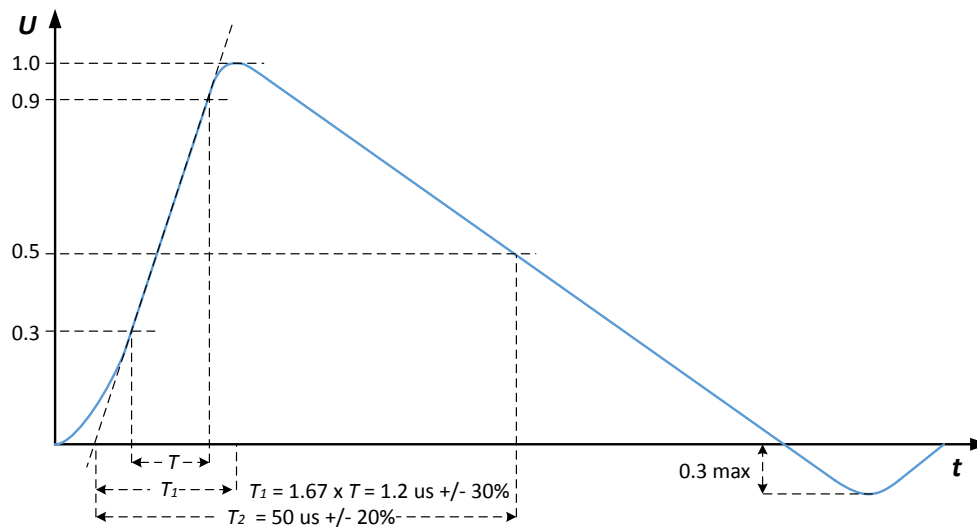

Figure 4.1. IEC 60747-17 Surge Test Waveform

The surge test voltages are typically high, so it may be necessary to test with the device submerged in oil to prevent arcing outside of the package.

For IEC 60747-17, the maximum surge isolation voltage V_{IOSM} for basic insulation is equal to 1.3 times the rated Impulse voltage V_{IMP} . The impulse voltage requirements are given in IEC 60664-1, and depend on the mains voltage supplied to the equipment, and on the “installation category”, or “overvoltage category” of the equipment. The installation/overvoltage category depends on how the equipment is connected to the mains (e.g., direct permanent connection vs. plug-connected equipment). Equipment operating at 220/240 Vac with plug-in connection (CAT II), for example, would have a required impulse withstand voltage of 4 kV, implying a surge test voltage of 5.2 kV. The surge test voltage requirement for reinforced insulation isolators is the larger of $V_{IMP} \times 1.3$ or 10 kV. So, a reinforced-rated isolator for the equipment in the example above would need to be tested at a surge voltage of 10 kV.

The IEC 60747-17 safety standard requires that magnetic and capacitive isolators maintain a minimum insulation resistance of $10^9 \Omega$ after being subjected to 25 surge discharges in one polarity followed by 25 surge discharges in the opposite polarity. The maximum repetition rate is 12 discharges/minute, and samples must be discharged for 1 hour (minimum) to 2 hours (maximum) before the polarity change.

Note that this “bipolar” surge testing for magnetic and capacitive isolators is more stringent than the “unipolar” surge required by the IEC 60747-5-5 safety standard for photocouplers, which allows different samples to be tested for each polarity.

4.5 TDDB/“End of Life - V_{IORM} “ Test

This testing uses accelerated life testing and statistical analysis to determine the isolator’s maximum rated repetitive peak isolation voltage, V_{IORM} . The testing must be performed by the isolator manufacturer and supporting data and signed documentation must be provided to the certifying test house to prove the safety requirement has been met.

Data is gathered by measuring the “time to failure” for different data sets at different voltages and temperatures, where a failure is an insulation resistance of less than 2 M Ω for basic insulation, or 4 M Ω for reinforced insulation, measured with 500 V_{DC} applied. A total of 288 parts, 32 parts each from 3 different lots, are tested at room temperature, and 144 parts, 16 each from 3 different lots, are tested at the maximum operating temperature. These sample groups are tested at a minimum of three different 50/60 Hz AC voltages, chosen such that the resulting mean time to failure values for the different voltages span two orders of magnitude.

The resulting time to failure data for each data set is analyzed per IEC 62539 to determine the time to failure probability line and confidence interval, and these results are then extrapolated to determine the reference working voltage (V_{REF}) for the required insulation grade. The V_{REF} extrapolation is based on a lifetime rated value of 20 years and specified failure rate of 1000 ppm for basic insulation or 1 ppm for reinforced insulation. IEC 60747-17 requires that a lifetime safety factor of 1.2 (equivalent to 24 years) be applied for basic insulation testing, and the factor is 1.5 (equivalent to 30 years) for reinforced insulation testing. A working voltage safety factor of 1.2 is applied to V_{REF} to determine V_{IORM} .

Note: The opto coupler safety standard (IEC60747-5-5) has no such life time estimation requirement. This represents another benefit of using digital isolators; their operating lifetime claims must be backed up with statistical data.

4.6 Creepage and Clearance Requirements to Prevent Arcing Outside of Device

To provide safety from electrical shock, an isolator’s insulation must be able to withstand the voltages expected in the target application. In addition, the spacing of metallic contacts on the outside of the device must be sufficient to prevent electrical conduction or “arcing” outside of the device. Equipment safety standards typically give spacing requirements in terms of minimum required “Creepage” and “Clearance” distances.

Creepage is the shortest distance along an insulating surface that an arc may travel (see figure below). Creepage requirements depend on the “comparative tracking index” (CTI) of the insulating material, the level of contamination (“pollution degree”) that may be present in the operating environment, and the working voltage of the device. Higher CTI numbers indicate a higher breakdown of the material, and generally reduce the creepage requirements. The creepage distance requirements for reinforced insulation are typically double of those for basic insulation certification.



Figure 4.2. Creepage

Clearance is the shortest path through air that an arc may travel (see figure below). A component’s clearance generally determines the “flashover voltage” (the voltage at which arcing will occur) for the device; the breakdown voltage of air is approximately 1 kV/mm, so arcing between contacts on either side of the barrier would be expected to occur at about 1 kV/mm times the clearance distance.



Figure 4.3. Clearance

The tables below show typical creepage and clearance requirements that might be applicable for telecom equipment certified to IEC 60950 or IEC 62368-1. For telecom equipment with a 320 Vrms lifetime working voltage, and requiring reinforced isolation, a minimum of 6.4 mm creepage would be required. Skyworks WB SOIC isolator package would meet this requirement. Designers should always consult the applicable equipment and component safety standards to understand the full creepage and clearance requirements for their application.

Table 4.1. Typical Creepage Requirements

Working Voltage	Minimum Creepage Distance, Pollution Degree 2, Material Group IIIa IIIb			
	IEC 60950		IEC 62368	
	Basic (mm)	Reinforced (mm)	Basic (mm)	Reinforced (mm)
250			2.5	5
300	3.2	6.4	3.0 (interpolated)	6.0 (interpolated)
320			3.2	6.4

Table 4.2. Typical Clearance Requirements

Required Withstand Voltage	Minimum Clearances			
	IEC 60950		IEC 62368	
	Basic (mm)	Reinforced (mm)	Basic (mm)	Reinforced (mm)
3000	2.6	5.2	2	3.8

4.7 Environmental Testing at Temperature and Humidity Extremes

To ensure that isolators continue to provide protection against shock after lifetime exposure to the various environmental conditions associated with their application, the equipment and component safety standards require temperature and humidity testing. Components are typically exposed to temperature and/or humidity extremes, followed by some form of isolator insulation integrity testing. This testing often takes 10 to 12 weeks to complete.

A typical temperature test required by safety standards such as IEC60950-1, IEC62368-1, or SAC GB4943-1 would consist of 10 cycles of the following temperature sequence:

1. 68 h at 135 °C
2. 1 h at 25 °C
3. 2 h at 0 °C
4. not less than 1 h at 25 °C

4.8 Observe “Safety Limiting Values” to Protect Against Insulation Damage from Excessive Power Dissipation in Nearby Circuitry

Isolators may still provide insulation to protect against electrical shock after being damaged by exposure to conditions outside of their normal operating conditions. IEC 60747-17 refers to the normal operating conditions, over which the isolator will function normally, as “limiting values”. The worst-case conditions (in excess of the limiting values) for which the device may cease to function but will still provide protection against shock are referred to as the “safety ratings” or “safety limiting values” of the device. If the safety limiting values are exceeded, the safety component may no longer provide its specified level of insulation.

Specific safety limiting values that must be specified in the isolator data sheet per IEC 60747-17 include:

- Max ambient or case safety temperature T_S
- Max input power dissipation P_{SI}
- Max output current or max power dissipation I_{SO} or P_{SO}

The equipment designer must make sure that an isolator used in a safety-related application is never exposed to conditions exceeding the device’s safety limiting values. IEC 60747-17 requires that datasheets for devices with reinforced insulation rating include a statement such as the following (there is a similar statement required for basic insulation):

“This coupler is suitable for “safe electrical insulation” only within the safety ratings. Compliance with the safety ratings shall be ensured by means of suitable protective circuits”².

It is therefore the equipment designer’s responsibility to ensure that operation within the device’s safety limiting values is maintained. In some applications, the designer may need to include additional protective circuitry, such as current limiting resistors or voltage clamping devices, to ensure that the safety limiting values are not exceeded.

Note that exceeding the safety limiting values on one side of a Skyworks series-capacitor-based isolator device does not necessarily mean that no insulation remains. As demonstrated later in this paper, exceeding the safety limiting values on one side of the device can damage one of the isolation capacitors, but leave the other isolation capacitor intact. In this case, although the insulating capability of the device is compromised, roughly half of the original insulation capability is retained.

4.9 Other Hazards

Isolator barrier insulation can also be directly or indirectly degraded by phenomena such as excessive common mode transients (CMT), electrical fast transient (EFT) events, or excessive electrostatic discharge (ESD). Requirements and test methodologies may be given in the relevant equipment and/or component safety standards. The CMTI, EFT, and ESD ratings should be provided in the component data sheets, and designers should be sure to select safety devices with ratings that meet the requirements of their applications.

5. Skyworks Series SiO₂ Capacitor-based Isolator Architecture

5.1 Skyworks Series Capacitor Architecture Inherently Provides Enhanced Safety

Skyworks isolators utilize two silicon dioxide (SiO₂) dielectric capacitors in series. This series capacitor architecture, pioneered and introduced by Skyworks in 2009 with the Si84xx series isolators, inherently provides enhanced safety as compared to a single-capacitor architecture. The two capacitors are located on separate dice, and this approach has a significant safety benefit, as damage or breakdown of only one capacitor's dielectric barrier insulation allows the remaining capacitor to continue providing safety isolation.

A cross sectional view of a typical Skyworks' isolator channel is depicted in the figure below. The isolation barrier comprises two capacitors, on separate dice, connected in series using bond wire(s). Each capacitor is composed of a SiO₂ dielectric (shown in red) with the capacitor plates implemented in metal on the top and bottom metallization layers of the integrated circuit die.

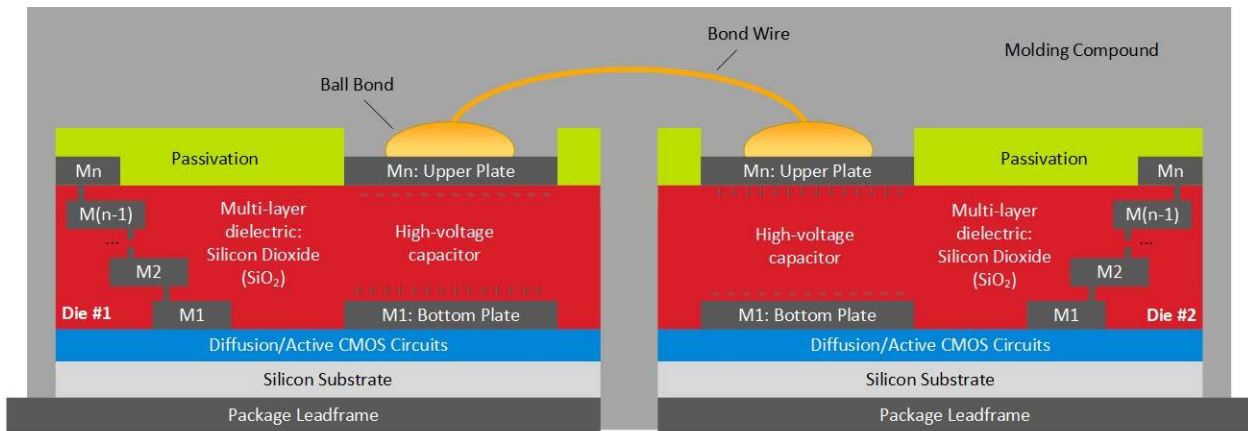

Figure 5.1. Cross-section of Skyworks Series SiO₂ Capacitor Isolation Architecture

The “Gen0” Si84xx family introduced in 2009 has been followed by three newer generations of Skyworks isolator families to date, with each new generation taking advantage of the original series SiO₂ capacitor architecture and bringing successive performance improvements. The Gen1 and Gen2 isolators are in full production, and engineering samples of Gen3 isolators are available at the time of this writing, with a Gen3 product launch scheduled for July 2019.

5.2 SiO₂ Dielectric Provides Long and Reliable Isolator Life

SiO₂ is an excellent material for isolation barrier insulation, because it is formed as a fundamental step in a tightly controlled semiconductor fabrication process, resulting in a very low defect density. This is important because isolation breakdown typically happens along defect paths in the insulation; so lower insulator defect density results in longer and more reliable isolator operating life.

New IEC safety standards require calculation of the isolator's maximum rated repetitive peak isolation voltage, V_{IORM} , based on statistical analysis of data gathered from accelerated life testing of a statistically valid sample set. The analysis is done per IEC60747-17, and the results are extrapolated to determine the operating lifetime for basic and/or reinforced isolation applications at a given working voltage. This testing and analysis process are often referred to as TDDB (time dependent dielectric breakdown) testing, and the results can provide both the manufacturer and the equipment designer with a broad assessment of how the isolator's barrier insulation will perform over time, temperature, and applied voltage. The figure below illustrates the TDDB performance for the Skyworks Si86xx isolator family. This curve indicates an expected 10 ppm failure rate operating life of 100 years for a 1000 V_{RMS} working voltage.

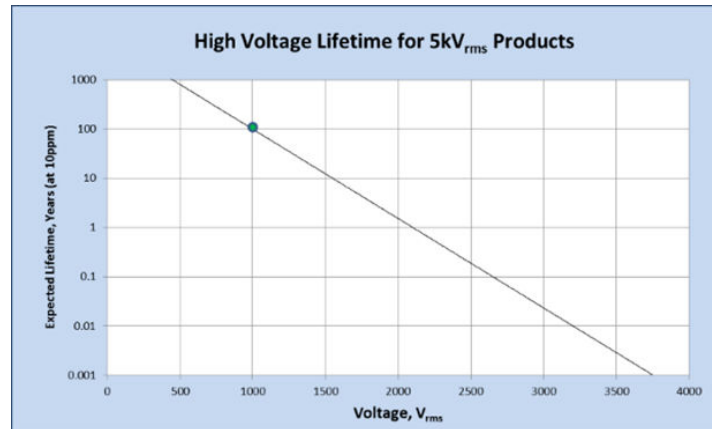

Figure 5.2. Typical Lifetime Curve for Si86xx Isolator

SiO₂ also has excellent dielectric strength, allowing very high withstand voltages to be achieved in small packages. The following are some of the salient advantages of silicon-dioxide as a dielectric/insulator for an isolation barrier:

- Proven, well controlled semiconductor process
- Characterized over more than 30 years of use
- Very low defects density means long isolator operating life
- Compact; no need for thick layers of SiO₂
- Dielectric strength: 500 V/ μ m (Other common dielectrics: ~ 50 - 200 V/ μ m)

5.3 EOS Events Can Damage the Isolation Barrier

Exceeding any isolator's specified maximum isolation voltage specifications (e.g., V_{IORM} , V_{IOTM} , V_{ISO} , V_{IOSM} , or V_{IMP}) can cause breakdown of the device's isolation barrier insulation. All standard isolator technologies, whether optical, magnetic, or capacitive, technically "fail shorted" (they no longer provide insulation resistance of $> 10^9 \Omega$) after breakdown and thus fail to provide safety from electrical shock. To maintain safety, designers must choose isolation devices with maximum isolation voltage specifications that are consistent with the requirements stated in the equipment safety standards for their equipment/application and ensure that the devices are operated within their safety limiting values, regardless of the isolator technology chosen.

As mentioned earlier, the isolation barrier insulation can also be damaged due to other events, such as the excessive heat that might result from excessive power dissipation in nearby circuitry under fault conditions. Skyworks series capacitor architecture has a safety advantage over other architectures in this case, because insulation damage caused by power dissipation on one die will typically be limited to that die, leaving the series isolation capacitor on the second die intact. In this case, the isolator device "fails open" and continues to provide safety from electric shock.

Operating conditions that exceed the maximum ratings for the device are considered electrical over stress (EOS) conditions. The table below lists some example minimum and maximum values that might apply to an isolator device. Conditions outside of these listed values represent EOS events which could cause degradation or permanent damage to the isolation barrier of the device.

As an example, the table indicates a maximum input supply voltage VDDI of 6 V. If 10 V was applied to VDDI, a "breakdown" event could occur, resulting in a low impedance to ground within the device. If the external supply for VDDI (often an LDO voltage regulator) can supply enough current to exceed the isolator's safety limiting values for input current or input power, then enough heat might be generated within the input-side die of the isolator to damage the dielectric insulator on that side. Because of Skyworks series capacitor architecture, it's likely that the output-side die, and thus half of the overall safety barrier, would remain intact. In this scenario, a 5 kVrms rated isolator which was damaged by an EOS event could still provide 2500 Vrms of withstand voltage.

Table 5.1. Example Minimum and Maximum Ratings for an Isolator

Parameter	Symbol	Min	Max	Unit
Storage Temperature	T_{STG}	-65	+150	°C
Ambient Temperature under Bias	T_A	-40	+125	°C
Junction Temperature	T_J	—	+150	°C
Input-side Supply Voltage V	VDDI	-0.6	6.0	V
Driver-side Supply Voltage	VDDA, VDDDB	-0.6	30.0	V
Voltage on any Pin with respect to Ground	V_{IO}	-0.5	VDD + 0.5	V
Peak Output Current (tPW = 10 μ s, duty cycle = 0.2%)	I_{OPK}	—	4.0	A
Lead Solder Temperature (10 sec.)		—	260	°C
Maximum Isolation (Input to Output) (1 sec) WB SOIC-16		—	6500	V_{RMS}
Maximum Isolation (Output to Output) (1 sec) WB SOIC-16		—	2500	V_{RMS}
Maximum Working Isolation Voltage	V_{IORM}	—	1200	V_{peak}
Surge Isolation Voltage	V_{IOSM}	—	6250	V_{peak}
Common-Mode Transient Immunity	CMTI	25	—	kV/ μ s
Device Power Dissipation	PD	—	1	W
ESD per AEC-Q100	HBM	—	4	kV
	CDM	—	2	kV

5.4 Single Faults and Double Faults for Skyworks Series Capacitive Isolator Architecture

For the following discussion, we will categorize failures in series capacitor-based isolators as either single fault events or double fault events. A single fault event occurs when one die in the two-dice structure fails to provide rated impedance ($> 10^9$ ohms), typically due to a high-power (exceeding limiting value) event on that side of the device. The extent of the damage to the given side depends on how much energy enters the component, and where that energy is dissipated within the component. A double fault event occurs when both dice are damaged, and both fail to provide rated impedance. A double fault condition is normally associated with insulation breakdown due to excessive voltage (greater than V_{IORM} , V_{IOTM} , V_{ISO} , V_{IOSM} , or V_{IMP}) applied across the barrier, but this could also be due to separate high-power “single fault”-type events occurring on each side of the device, or a single fault that generated enough heat to damage the mold compound encapsulating both dice.

The figure below illustrates three paths where energy from EOS conditions could enter, and potentially damage, an isolator. The damage from electrical overstresses EOS1 and EOS2 would typically be localized to a given side of the device, thus resulting in a single fault event that leaves a basic insulation capability intact. EOS3 represents electrical overstresses that transverse the isolation barrier. EOS3 conditions are generally more hazardous. Please see [Section 6](#) for results of EOS1 and EOS2 testing. See [Section 7](#) for more details on EOS3.

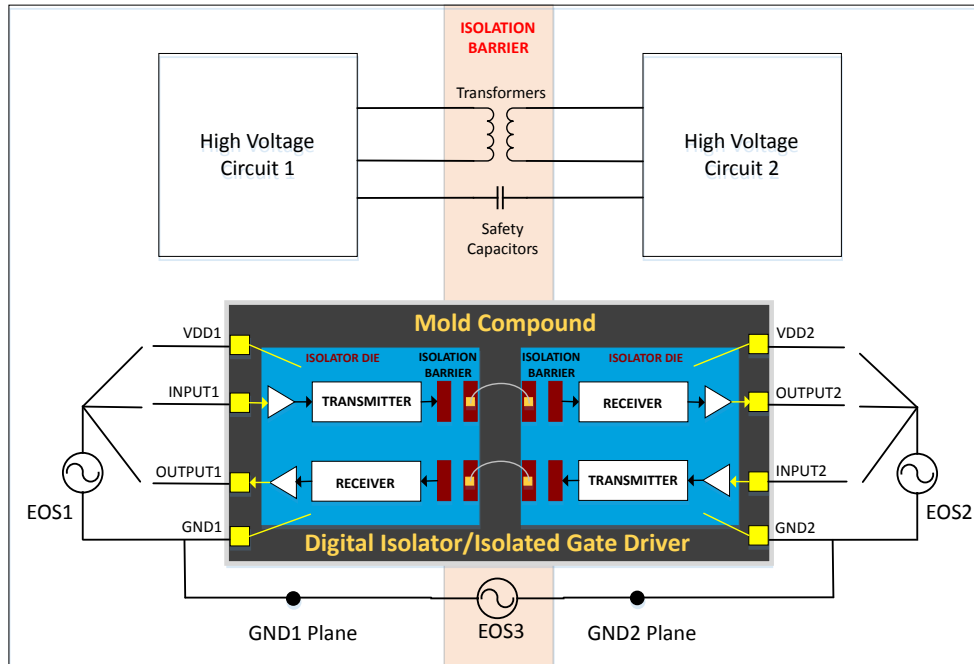

Figure 5.3. Possible EOS Locations on Digital Isolator/Isolated Gate Driver

Note: It’s common for isolated gate drivers to have 3 dice in a single package; one die for the input side, and separate dice for the low-side and high-side gate drivers on the output side of the device. For the purpose of this discussion, a “double fault” condition exists when the input side die and at least one of the two output side dice are damaged. Damage to both output dice but not to the input side die would be considered a “single fault” case.

6. Single Fault Performance for Skyworks Isolators

To test the single-fault performance of Skyworks Gen3 isolators, several devices were exposed to electrical overstress in either the EOS1 or the EOS2 configuration to intentionally induce failures.

In the first test sequence, the supply voltage for either side 1 or for side 2 was increased well beyond the absolute max rating (typically 7 V) for the isolator. After damage to the die structure was evidenced by excessive current draw, the current limit was increased to a point where the safety limiting values applicable for that side of the device were exceeded. It was then verified that the die on the electrically overstressed side of the device failed to provide the required isolation impedance, indicating damage to the isolation capacitor's insulating dielectric on this die. [Figure 6.1 Visible Package Damage after EOS1-Induced Failure on page 20](#) shows visible package damage typically resulting from this kind of testing. [Figure 6.2 Single Fault Failure Resulting from EOS1 Event on page 20](#) shows a photograph of an isolator that has been decapsulated, exposing the die, after an EOS1-induced failure. In this series of tests, damage was observed only on the die that was exposed to the EOS1 or EOS2 overstress, and in all cases, the device “failed open”, continuing to provide $> 10^9 \Omega$ of isolation resistance after the induced failure.



Figure 6.1. Visible Package Damage after EOS1-Induced Failure

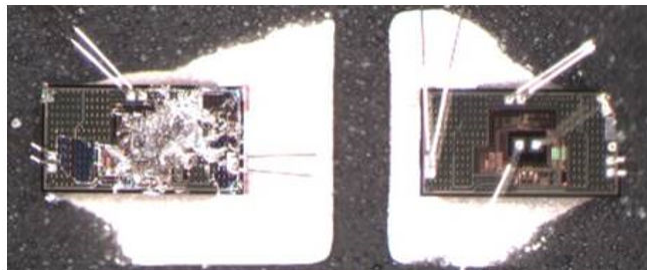

Figure 6.2. Single Fault Failure Resulting from EOS1 Event

In a second test sequence, the supply for either side 1 or side 2 was raised to 20 V to ensure damage. The EOS was followed by measurement of the side 1 to side 2 impedance, then a 60 second V_{ISO} hipot test was performed from side 1 to side 2 to ensure that the damaged devices still provided “basic isolation” withstand capability. Finally, to assess the extent of the damage, an EOS3-configuration insulation breakdown test was performed, by ramping the applied voltage at a 1 kVrms/sec rate until barrier break down occurred. The results from this test sequence are summarized in the table below.

Table 6.1. Gen3 Isolator Single Fault Performance Summary

Device Under Test (Gen3)	Test Condition	Impedance after Event	Hipot Test (3 kVrms 60 sec)	Breakdown Test (1 kVrms/sec ramp)
DUT1 Side 1	Side 1 VDD ramped to 20 V+ to induce damage	$>10^9 \Omega$	Pass	5.79 kVrms
DUT2 Side 1	Side 1 VDD ramped to 20 V+ to induce damage	$>10^9 \Omega$	Pass	4.64 kVrms
DUT3 Side 1	Side 1 VDD ramped to 20 V+ to induce damage	$>10^9 \Omega$	Pass	6.31 kVrms

Device Under Test (Gen3)	Test Condition	Impedance after Event	Hipot Test (3 kVrms 60 sec)	Breakdown Test (1 kVrms/sec ramp)
DUT4 Side 1	Side 1 VDD ramped to 20 V+ to induce damage	$>10^9 \Omega$	Pass	5.79 kVrms
DUT5 Side 2	Side 2 VDD ramped to 20 V+ to induce damage	$>10^9 \Omega$	Pass	4.4 kVrms
DUT6 Side 2	Side 2 VDD ramped to 20 V+ to induce damage	$>10^9 \Omega$	Pass	5.2 kVrms
DUT7 Side 2	Side 2 VDD ramped to 20 V+ to induce damage	$>10^9 \Omega$	Pass	4.85 kVrms
DUT8 Side 2	Side 2 VDD ramped to 20 V+ to induce damage	$>10^9 \Omega$	Pass	7.09 kVrms

Skyworks Gen1 and Gen2 isolation devices were tested in the same manner as Gen3. However, for these earlier generation devices, the post-damage hipot test voltage was reduced to correspond to the isolation voltage ratings for these device families. All devices from these earlier generations also “failed open”, continuing to provide the $>10^9 \Omega$ of insulation impedance required for basic insulation after faults were induced. The post EOS1- or EOS2-induced failure results for the three generations of Skyworks isolators are summarized in the table below.

Table 6.2. Summary of Isolation Performance after EOS1- or EOS2-induced Failure

Isolation Technology	Isolator Family	Viso (1 minute) after EOS1or EOS2	Post-Fault Impedance
Gen1	Si86xx, Si823x, Si890x	1 kVrms	$>10^9 \Omega$
Gen2	Si86xxT, Si87xx, Si826x	2.5 kVrms	$>10^9 \Omega$
Gen3	Si8921/3x/4x	3 kVrms	$>10^9 \Omega$

The results presented here indicate a high probability of Skyworks series capacitor isolators continuing to provide a high insulation impedance (a minimum of $10^9 \Omega$), even after being subjected to EOS1- or EOS2- induced faults. These results also provide a means to compare the post-single-fault isolation performance for the 3 generations of isolation devices. Of course, equipment designers should always consult the applicable equipment safety standards to determine the insulation requirements for their application, then select isolation devices with isolation voltage ratings that meet these requirements and ensure that the isolators are operated within their safety limiting values.

In addition to these tests, two other test sequences were performed on samples as follows:

Samples of Gen1 and Gen3 products were tested with 60 V applied to the VDD pin on either side and DUTs were then measured for insulation resistance, followed by breakdown testing as described in the section above. Other samples of Gen1 and Gen3 products were tested with 60 V applied to an I/O pin and were also tested for insulation resistance and breakdown test. Results are summarized in the table below:

Table 6.3. Insulation Resistance and Breakdown Test Results Summary

Product Family	Isolation Technology	Impedance After Event	Range for Breakdown Test (1 kVrms/sec Ramp Rate)
Si8921x	Gen3	$> 10^9 \Omega$	4.6 kVrms - 10.1 kVrms
Si86xx	Gen1	$> 10^9 \Omega$	2.5 kVrms - 7.0 kVrms

Note: The Si86xx Gen1 product family is in current production. Gen3 samples are available, product to be launched in 3Q2020.

7. Double Fault Performance for Skyworks Isolators

Isolator insulation breakdown is typically caused by excessive voltage (greater than V_{IORM} , V_{IOTM} , V_{ISO} , V_{IOSM} , or V_{IMP}) being applied across the isolation barrier, as depicted by EOS3 in the figure below. Breakdown from side 1 to side 2 of the isolator is referred to as a “double fault” in this discussion of series capacitor-based isolators, because this breakdown requires dielectric damage in the isolation capacitors on both dice. Note, however, that the outcome is generally the same with optical or magnetic isolators; following insulation breakdown due to excessive voltage across the isolation barrier, the damaged device fails to provide the $>10^9 \Omega$ of insulation impedance required for basic insulation, and thus “fails shorted”.

The following figure shows extensive damage on both dice of a decapsulated digital isolator after intentionally ramping the applied voltage until insulation breakdown occurred.

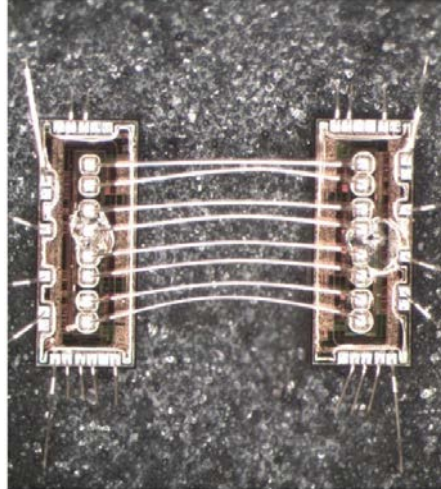

Figure 7.1. Double Fault Event: Both Side 1 and Side 2 Dice are Damaged

Skyworks pioneering series capacitor-based isolators provide the requisite isolation ratings while reducing the likelihood of isolation barrier breakdown as compared to competing technologies. The table below compares some key performance characteristics for the 3 generations of Skyworks isolators.

Table 7.1. Skyworks Reinforced Series Capacitor Isolation Performance by Generation

Characteristic	Symbol	Gen1	Gen2	Gen3	Units
UL Dielectric Isolation Voltage (60 sec withstand)	V_{ISO}	5	5	5	kV_{RMS}
VDE Working Voltage	V_{IORM}	Up to 891	Up to 1200	Up to 2121	V_{PK}
Rated Surge Voltage (1.2/50 us waveform, tested in oil)	V_{IOSM}	3077 (4 kV Unipolar Test)	6250 (10 kV Unipolar test)	6250 (10 kV Bipolar test)	V_{PK}
Dielectric thickness	DTI	14	16	36	μm

8. Summary

This Application Note addresses safety considerations for Skyworks' series capacitor-based isolator devices. When isolators are used to provide insulation from high voltages in safety-related applications, failure of the isolator's insulation could pose a risk of electric shock.

National and international equipment and component safety standards specify requirements and test methodologies that help ensure certified isolation devices meet their isolation ratings. Skyworks Gen3 isolators meet the stringent reinforced insulation requirements of the new international magnetic and capacitive isolator safety standard IEC 60747-17. And although all isolators, whether optical, magnetic, or capacitive, generally "fail short" when breakdown occurs due to voltages across the isolation barrier exceeding their rated maximums, the series capacitor isolator architecture pioneered by Skyworks can provide enhanced safety performance under "single fault" conditions.

When using isolators in safety-related circuit applications, designers must select isolation devices that meet the equipment safety requirements for their application and must also be sure that the selected isolation devices are operated within their safety limiting to ensure insulation integrity and safety from electric shock. It is therefore critical that designers understand the failure modes, specifications, and safety limiting values for isolators used in safety-related applications in their equipment. This is necessary both to enable selection of appropriate devices, and to understand if and when additional external circuitry must be added to keep the isolator operating conditions within the specified safety ratings.

Choosing isolator components that are pre-certified to the applicable component safety standards helps ensure that these components meet their specified performance characteristics and can also help speed the equipment qualification or certification process. Skyworks isolators are certified to several common safety standards, and documentation for these certifications is made available to customers.

9. References

1. Skyworks White Paper, *The Benefits of Opto-Coupled and Digital Isolators in Circuit Design Today*
2. IEC 62368-1 (UL 62368-1), *ICT and AV equipment- Part 1 Safety requirements*, International Electrotechnical Commission
3. IEC 60601-1 *Medical Electrical Equipment - Part 1: General Requirements for Basic Safety and Essential Performance*, International Electrotechnical Commission
4. IEC 61010-1 (UL-61010-1) *Safety Requirements for Electrical Equipment for Measurement, Control, and Laboratory Use*
5. SAC GB4943-1, *Information Technology Equipment – Safety, Part 1: General Requirements*, Standardization Administration of China
6. IEC 60747-5-5, *Semiconductor devices - Discrete devices - Part 5-5: Optoelectronic devices – Photocouplers*, International Electrotechnical Commission
7. VDE 0884-10 and VDI 0884-11, *Semiconductor Devices – Magnetic and Capacitive Coupler for Basic and Reinforced Isolation*, Verband der Elektrotechnik, Elektronik und Informationstechnik e.V.
8. IEC 60747-17 Preliminary Draft. January 2017, *Semiconductor Devices – Magnetic and Capacitive Coupler for Basic and Reinforced Insulation*, International Electrotechnical Commission
9. UL 1577 *Standard for Safety, Optical Isolators*, Underwriters Laboratories
10. IEC 60060-1:2010 Ed 3.0, *High-Voltage Test Techniques – Part 1: General Definitions and Test Requirements*. September 2010, International Electrotechnical Commission
11. IEC 60664-1, *Insulation Coordination for Equipment within Low-Voltage Systems - Part 1: Principles, Requirements and Tests*, International Electrotechnical Commission
12. IEC 62539 (IEEE 930), *Guide for the Statistical Analysis of Electrical Insulation Breakdown Data*, International Electrotechnical Commission
13. Si86xx Datasheets at www.skyworksinc.com
14. Si823x datasheets at www.skyworksinc.com
15. Skyworks Application Note, *AN583: Safety Considerations and Layout Recommendations for Digital Isolators*

10. Document Change List

Revision 0.5

January 2020

- General content updates of [Section 4.8](#) and [Section 5.4](#).

Revision 0.2

June 2019

- Updated various figures.
- General editing of various sections.

Revision 0.1

April 2019

- Initial release.



**Connecting Everyone
and Everything,
All the Time**



Portfolio

skyworksinc.com

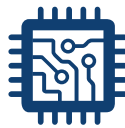

Quality

skyworksinc.com/quality



Support & Resources

skyworksinc.com/support

Copyright © 2022 Skyworks Solutions, Inc. All Rights Reserved.

Information in this document is provided in connection with Skyworks Solutions, Inc. ("Skyworks") products or services. These materials, including the information contained herein, are provided by Skyworks as a service to its customers and may be used for informational purposes only by the customer. Skyworks assumes no responsibility for errors or omissions in these materials or the information contained herein. Skyworks may change its documentation, products, services, specifications or product descriptions at any time, without notice. Skyworks makes no commitment to update the materials or information and shall have no responsibility whatsoever for conflicts, incompatibilities, or other difficulties arising from any future changes.

No license, whether express, implied, by estoppel or otherwise, is granted to any intellectual property rights by this document. Skyworks assumes no liability for any materials, products or information provided hereunder, including the sale, distribution, reproduction or use of Skyworks products, information or materials, except as may be provided in Skyworks' Terms and Conditions of Sale.

THE MATERIALS, PRODUCTS AND INFORMATION ARE PROVIDED "AS IS" WITHOUT WARRANTY OF ANY KIND, WHETHER EXPRESS, IMPLIED, STATUTORY, OR OTHERWISE, INCLUDING FITNESS FOR A PARTICULAR PURPOSE OR USE, MERCHANTABILITY, PERFORMANCE, QUALITY OR NON-INFRINGEMENT OF ANY INTELLECTUAL PROPERTY RIGHT; ALL SUCH WARRANTIES ARE HEREBY EXPRESSLY DISCLAIMED. SKYWORKS DOES NOT WARRANT THE ACCURACY OR COMPLETENESS OF THE INFORMATION, TEXT, GRAPHICS OR OTHER ITEMS CONTAINED WITHIN THESE MATERIALS. SKYWORKS SHALL NOT BE LIABLE FOR ANY DAMAGES, INCLUDING BUT NOT LIMITED TO ANY SPECIAL, INDIRECT, INCIDENTAL, STATUTORY, OR CONSEQUENTIAL DAMAGES, INCLUDING WITHOUT LIMITATION, LOST REVENUES OR LOST PROFITS THAT MAY RESULT FROM THE USE OF THE MATERIALS OR INFORMATION, WHETHER OR NOT THE RECIPIENT OF MATERIALS HAS BEEN ADVISED OF THE POSSIBILITY OF SUCH DAMAGE.

Skyworks products are not intended for use in medical, lifesaving or life-sustaining applications, or other equipment in which the failure of the Skyworks products could lead to personal injury, death, physical or environmental damage. Skyworks customers using or selling Skyworks products for use in such applications do so at their own risk and agree to fully indemnify Skyworks for any damages resulting from such improper use or sale.

Customers are responsible for their products and applications using Skyworks products, which may deviate from published specifications as a result of design defects, errors, or operation of products outside of published parameters or design specifications. Customers should include design and operating safeguards to minimize these and other risks. Skyworks assumes no liability for applications assistance, customer product design, or damage to any equipment resulting from the use of Skyworks products outside of Skyworks' published specifications or parameters.

Skyworks, the Skyworks symbol, Sky5[®], SkyOne[®], SkyBlue[™], Skyworks Green[™], Clockbuilder[®], DSPLL[®], ISOmodem[®], ProSLIC[®], and SiPHY[®] are trademarks or registered trademarks of Skyworks Solutions, Inc. or its subsidiaries in the United States and other countries. Third-party brands and names are for identification purposes only and are the property of their respective owners. Additional information, including relevant terms and conditions, posted at www.skyworksinc.com, are incorporated by reference.

Skyworks Solutions, Inc. | Nasdaq: SWKS | sales@skyworksinc.com | www.skyworksinc.com

USA: 781-376-3000 | Asia: 886-2-2735 0399 | Europe: 33 (0)1 43548540