



# Effective Design Techniques for Signal and Power Supply Isolation

## Introduction

Today, more than ever, electronics designers face a common set of goals: achieving higher throughput, higher resolution, more efficient systems and reduced time to market. In fields such as industrial automation, medical electronics or telecommunication systems, it is often necessary to electrically isolate multiple signals to enable sub-systems to share data or control signals without allowing noise or high voltages to interfere with system integrity and safety.

Isolating signals is not enough to provide true isolation from noise and high voltages – the power supplies need to be isolated too. Designing an isolated power supply is often something that takes specialized skills and experience. It costs precious time and multiple iterations to get it right.

## Signal Isolation Basics

Isolating signals is necessary to provide the following design-critical functions:

**Protection from high voltages:** Isolation provides a dielectric barrier that acts as an insulator against high voltages in systems where higher power levels are required.

**Level translation:** Enabling noise-free data transfer between circuits that operate at different voltage rails is a common challenge for electronics designers. Although there are many non-isolated level shifters available to circumvent this problem, using an isolator provides several solid advantages. Isolators are the most noise-free and robust solution, and they prevent parasitic paths that may inadvertently switch devices on or off.

**Noise elimination:** Isolated products restrict the ground current (return path) of an electrical circuit to only one side of the barrier, enabling a noise-free environment for sensitive measurements on the other side.

## System Considerations

In order to ensure that true isolation has been achieved, it is important for the circuit designer to eliminate all possible coupling paths from one circuit (Circuit A in Figure 1) to the other that needs to be isolated (Circuit B in Figure 1). Hence, when isolating signals, it is equally important to isolate the power supplies. For a circuit designer, the challenge of isolating signals is really two-fold: to provide safe, reliable and accurate signal isolation as well as power isolation. There are multiple solutions available for signal isolation to suit the needs of designers – based on data rate capabilities, jitter restrictions, noise immunity concerns, high voltage capability, compliance with the various isolation component safety standards etc. However, for many applications where only a watt or so of isolated power is required, there have not been readily available or easily implementable solutions for power isolation.

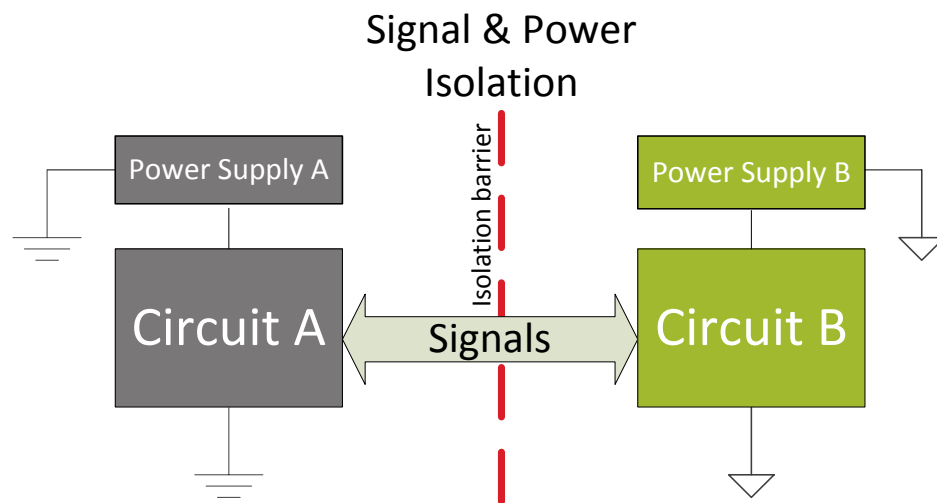

*Figure 1: Isolating signals and power is necessary*

## Application Example

Factory automation systems depend on efficient and reliable real time distributed networks to monitor and control complex manufacturing processes. A typical and simplified hierarchical structure used in these systems is shown in Figure 6. Human machine interface in the control room at the top is linked to an intermediary controller level and finally down to the physical layer where the sensors and actuators are situated as part of motor drive units or machines controlled by PLC's (programmable logic controllers).

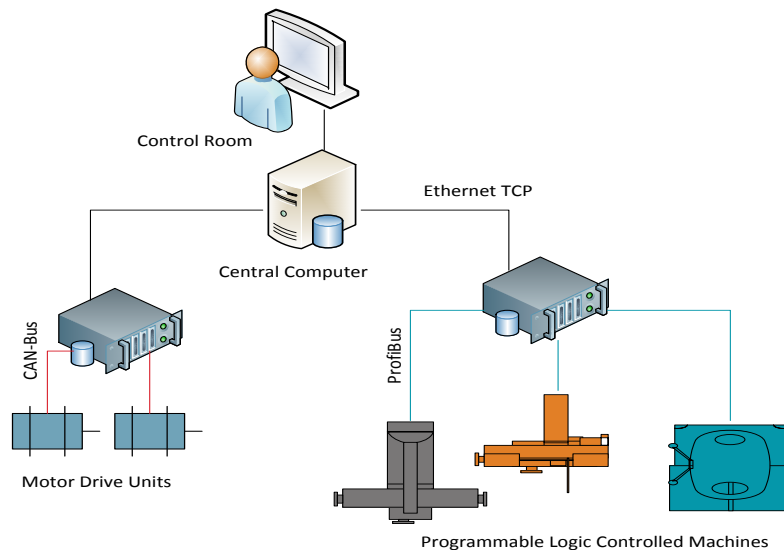

Figure 2: Example of factory automation system requiring isolation

The physical layer connects the sensors and actuators in a process module and across the factory floor or plant. As shown in Figure 2, a CAN-based bus communicates with the various motor control units while an RS-485-based bus (PROFIBUS) communicates with the various machines on the factory floor. These physical layers are used commonly in industrial automation because they are very robust even in a noisy environment and support the long distance, multi-point communication needed on a factory floor that may cover hundreds of square meters. These buses have multiple nodes that connect to the bus through a CAN or an RS-485 transceiver. Isolating these interfaces is critical to protect against high voltages, high electromagnetic (EM) noise and large ground potential differences within the network.

Figure 3 shows a detailed diagram of an RS-485 transceiver node that has been isolated from the processor. The isolated power solution is referred to as the isolated dc-dc converter block. Very few easy-to-deploy, high-performance solutions isolated power solutions are available to developers. Designers frequently have to design their own

solutions from scratch to provide isolated power to the secondary side of the isolator and to the RS-485 transceiver on the isolated side.

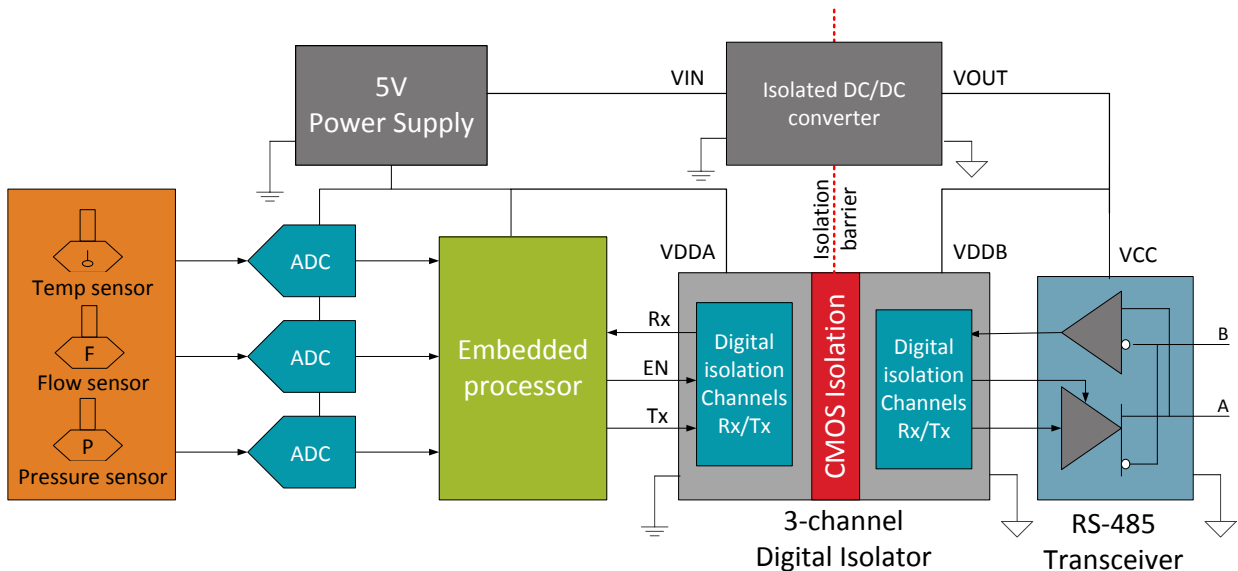

Figure 3. Isolating an RS-485 transceiver

The transceiver in Figure 3 is a half-duplex device with receive and transmit lines connected together. It communicates with the RS-485 bus through differential I/Os labelled A and B in Figure 3. The transceiver provides the interface to the processor through its single-ended digital I/Os labelled Rx (receiver) and Tx (transmitter) and an EN (enable pin) signal that controls the transmitter.

The transceiver typically has two to four digital signals that require fast and accurate digital isolation and needs 0.5W to 1W of power, which has to be supplied by a dedicated isolated source with the following characteristics:

**Compact solution:** Depending on the particular application, space may be at a premium, and, in general, a smaller BOM is always better for manufacturability, reliability and cost.

**High efficiency:** It is important to have a compact solution with high efficiency so that heat is kept to a minimum and green energy standards can be maintained.

**Low EMI:** It is critical to keep the overall system noise to a minimum for sensitive measurements. To fine tune the emissions spectrum to a specific use case, it is preferable to have a programmable frequency option which lets users choose the switching frequency of the DC/DC converter.

**Safety features:** In industrial environments where safety is a top concern, it is recommended that the device have a soft start option to avoid inrush currents, current limiting capability and thermal detection and auto shutdown in case of excessive heat conditions.

**Multiple isolation channels:** Lastly, the solution needs to support multiple isolation channels with a minimum of 2.5kVrms rated isolation capability for meeting safety standards. The isolator needs to have excellent signal integrity even in a high noise environment.

## Solutions for industrial isolation

There are only a few products on the market that strike the right balance between compactness and the ability to deliver power and between minimizing emissions while maximizing efficiency.

Discrete solutions that use FET's, controllers, single channel isolators (or optos) for feedback as well as other supporting BOM for power isolation are very common. Such solutions have to be designed from scratch and take specialized experience and skill and could take multiple iterations to get right.

Some solutions integrate digital isolation and the power transformer in a single IC package. These air core transformers have poor coupling coefficients and need to be driven at much high frequencies to deliver equivalent power. This results in a much higher emissions profile for EMI, which is a strong deterrent for many designers.

In addition, the power converter efficiency of such products is usually low, from 10-35%. In applications where space is at a premium, efficiency is a "don't-care" and high emissions not a problem, these might work. But more often than not, such solutions are not compelling.

There are other solutions that integrate the signal isolators and the dc-dc converter and are designed to work with a discrete transformer. This approach is optimized for the highest efficiency and integration. These solutions are a total solution, are compact and can deliver up-to 2W of power at about 78% efficiency.

For example, Silicon Labs' Si88xx isolation products combine quad digital isolators with a modified fly-back topology dc-dc converter with built-in secondary sensing feedback control. The Si88xx devices have been designed for very low emissions by employing dithering techniques.

Additional features include a soft start capability to avoid inrush currents on startup, cycle-by-cycle current limiting, thermal detection and shutdown for over-temperature events, and cycle skipping to reduce switching losses and thus boost efficiency at lighter loads.

Options for the Si88xx isolators are available for various voltage levels from 5 V to 24 V and for various combinations of digital isolation channels and their directionality. This solution leverages Silicon Labs' proprietary signal isolation technology, with its signature low EMI profile, to provide high integration, high efficiency and very low EMI.

Figure 4 provides a simplified block diagram of an Si88xx isolator. In addition to the four high-speed digital isolation channels, the Si88xx device integrates a dc-dc controller and internal FET switches that modulate power to the external transformer. The output side incorporates feedback through an external resistor divider to provide excellent line and load regulation.

The dc-dc converter uses dithering techniques to minimize EMI peaks and a zero voltage switching (ZVS) scheme to minimize power loss when modulating power to the transformer. The device uses cycle skipping at light loads to minimize switching losses and boost efficiency. Multiple safety features include cycle-by-cycle current limiting, soft start to avoid inrush currents and thermal shutdown. The device also incorporates several user-programmable features such as soft start time control, a shutdown option for the dc-dc converter and switching frequency control to fine-tune the EMI profile.

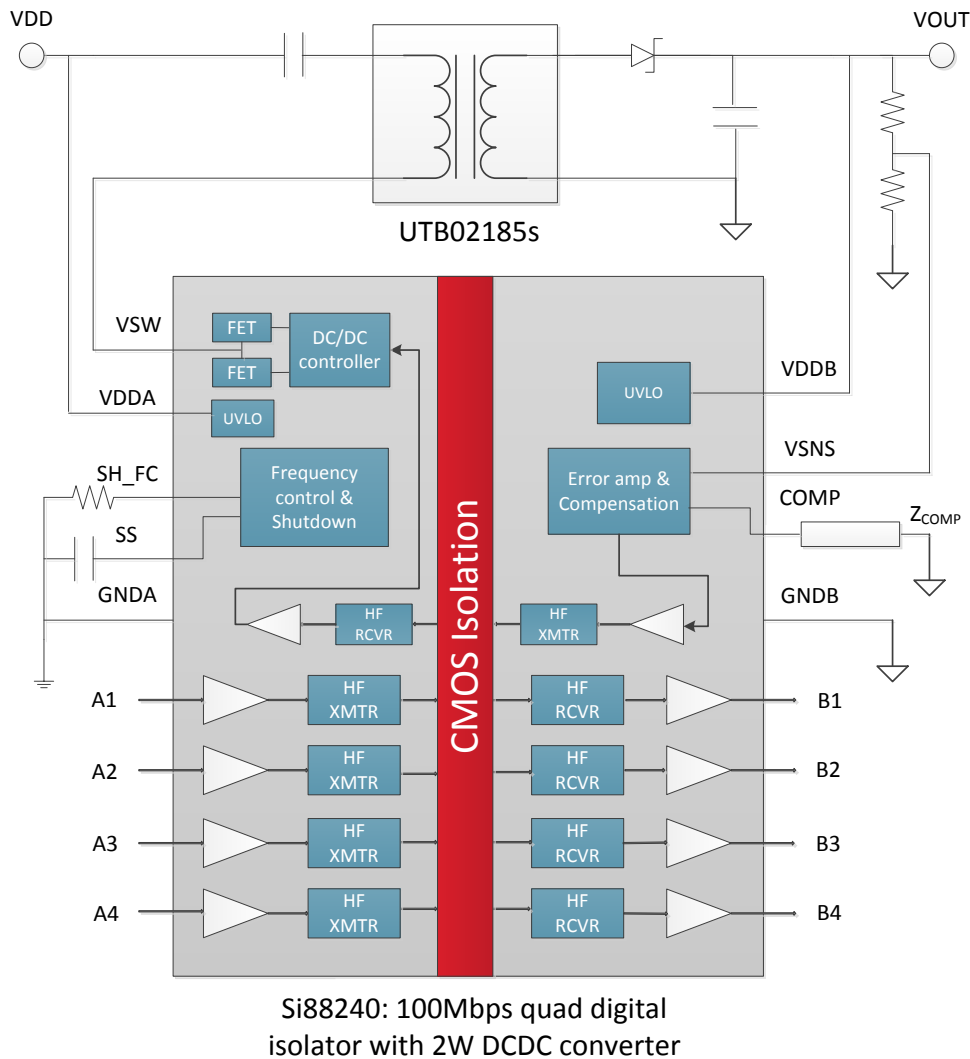

*Figure 4: High speed digital isolator with integrated dc-dc converter*

In the application example above, the Si88xx is an ideal fit as shown in Figure 5 below. The isolated transformer is rated to 2.5kVrms and is designed to work with the Si88xx IC. By adding a few other components like resistors, diodes and capacitors, a complete power and signal isolation solution is available.

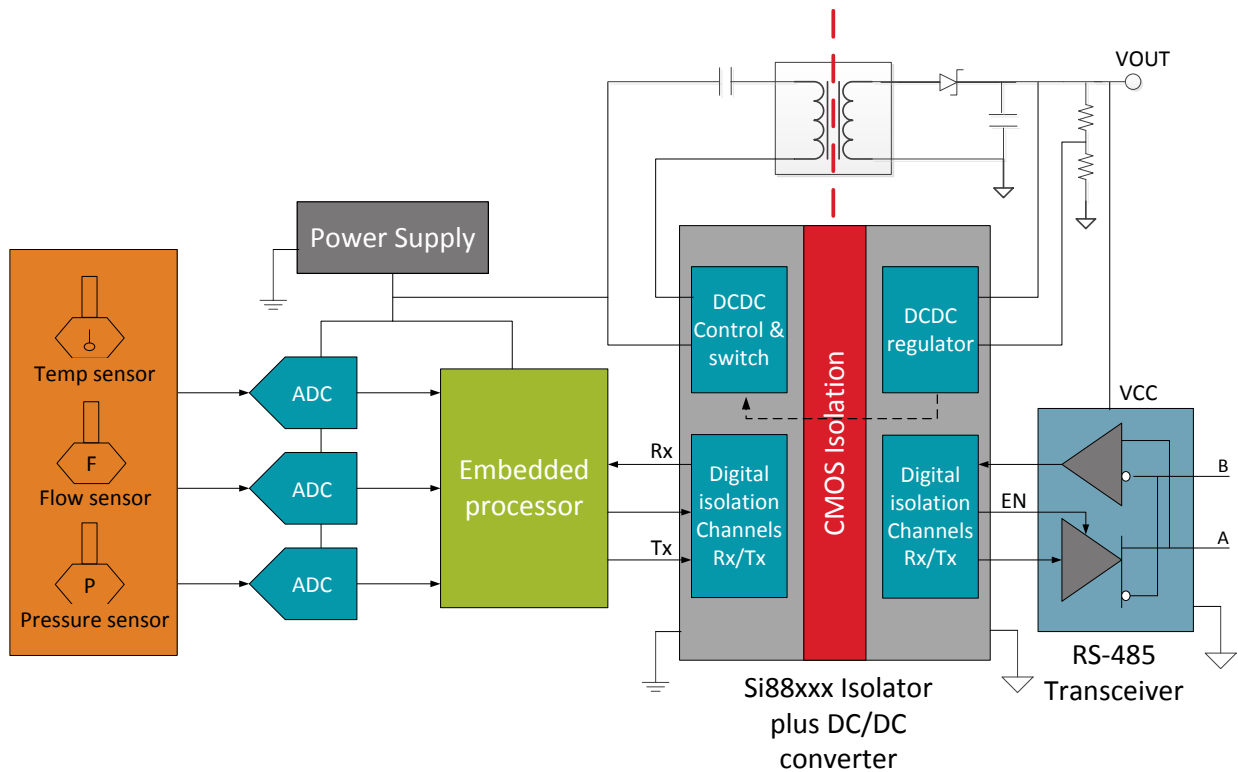

Figure 5: Si88xx solution used for isolating the RS-485 interface

## Summary

Elegant solutions that combine excellent digital isolation characteristics with high power conversion efficiency and extremely low EMI emissions are now available that make development easier for the digital designer. These are plug and play solutions that eliminate costly design time and iterations and take the guesswork completely out of the picture, ensuring first time success and the fastest time to market.

Learn more about the Si88xxx family of Isolation products at [www.silabs.com/Si88xx](http://www.silabs.com/Si88xx).



## **About Silicon Labs**

Silicon Labs (NASDAQ: SLAB) is a leading provider of silicon, software and system solutions for the Internet of Things, Internet infrastructure, industrial control, consumer and automotive markets. We solve the electronics industry's toughest problems, providing customers with significant advantages in performance, energy savings, connectivity and design simplicity. Backed by our world-class engineering teams with unsurpassed software and mixed-signal design expertise, Silicon Labs empowers developers with the tools and technologies they need to advance quickly and easily from initial idea to final product. [www.silabs.com](http://www.silabs.com)