



Si522xx PCI-Express Gen 1 to Gen 7 Clock Generator

The Si52212, Si52208, Si52204, and Si52202 are a family of high-performance and low-power PCI Express clock generators for 1.5 V to 1.8 V PCIe Gen 1/2/3/4/5/6/7 and SRIS applications. These devices can source twelve, eight, and four 100 MHz PCIe differential clock outputs, respectively, plus one 25 MHz LVCMOS reference clock output. The Si52202 can source two 100 MHz PCIe clock outputs only. All differential clock outputs are compliant with PCIe Gen1/2/3/4/5/6/7 common clock and separate reference clock architecture specifications.

The Si52212, Si52208, Si52204, and Si52202 feature individual hardware control pins for enabling and disabling each output, spread spectrum enable/disable for EMI reduction, and differential output frequency selections of 100 MHz, 133 MHz, or 200 MHz. These features can also be controlled via I²C.

Their small footprint and low power consumption make this family of PCIe clock generators ideal for industrial and consumer applications.

For more information about PCI-Express, Skyworks complete PCIe portfolio, application notes, and design tools, including the Skyworks PCIe Clock Jitter Tool for PCI-Express compliance, please visit the Skyworks [PCI Express Learning Center](#).

Applications

- Servers
- Storage
- Data centers
- PCIe add-on cards
- Network Interface Cards (NICs)
- Graphics adapter cards
- Multi-function printers
- Digital Single-Lens Reflex (DSLR) cameras
- Digital still cameras
- Digital video cameras
- Docking stations

Key Features

- 12/8/4/2-output PCI-Express Gen1/2/3/4/5/6/7 clock generators
- LP-HCSL output drivers
- Common clock and SRIS compliant
- Individual hardware control pins and I²C controls for output enable, spread spectrum enable, and frequency select
- Triangular spread-spectrum for EMI reduction, down-spread 0.25% or 0.5%
- Internal 100 Ω or 85 Ω line matching
- Adjustable output slew rate
- Power down (PWRDNb) function supports Wake-on LAN (except Si52202)
- One non-spread, LVCMOS reference clock output (except Si52202)
- 25 MHz crystal input or clock input
- I²C support with readback capabilities
- Extended temperature: -40 to 85 °C
- 1.5 to 1.8 V power supply, with separate VDD and VDD_IO
- For RoHS and other product compliance information, see the [Skyworks Certificate of Conformance](#).

1. Feature List

- 12/8/4/2-output 100 MHz PCIe Gen 1/2/3/4/5/6/7 and SRIS compliant clock generator, with push-pull HCSL output drivers
 - High port count with push-pull HCSL outputs to support highly integrated solution, eliminating external resistors for the HCSL output drivers
- Low jitter of 0.085 ps (RMS) max to meet PCIe Gen 6 specifications with design margin
- Low power consumption
 - Lowest power consumption in the industry for a two-output PCIe clock generator
- Individual hardware control pins and I²C controls for Output Enable, Spread Spectrum Enable, and Frequency Select functions
 - Output Enable function easily disables unused outputs for power saving
 - Spread Enable function to turn on/off spread spectrum and to select spread levels, either down spread 0.25% or 0.5%
 - Frequency Select function to select output frequency of 100 MHz, 133 MHz, or 200 MHz (except Si52202 where the output frequency is limited to 100 MHz. Please contact Skyworks for 133 MHz or 200 MHz in the Si52202)
 - All above functions are controlled by individual hardware pins or I²C
- Internal 100 Ω or 85 Ω impedance matching
 - Eliminates external line matching resistor to reduce board space
- Adjustable slew rate to improve signal quality for different applications and board designs
- Power-down (PWRDNb) function supports Wake-on LAN (except Si52202)
- One non-spread, 25 MHz LVCMOS reference clock output (except Si52202)
 - A buffered 25 MHz LVCMOS clock output to drive ASICs or SoCs on-board
- 25 MHz reference input
 - Supports a standard crystal or clock input for flexibility
- I²C support with read-back capabilities
- 1.5 V to 1.8 V power supply with separate VDD and VDD_IO (1.05 V to 1.8 V)
- Temperature range: -40 °C to 85 °C
- Small QFN packages to optimize board space. Smallest 2-output PCIe clock generator in the industry
 - 64-pin QFN (9 x 9 mm): 12-output
 - 48-pin QFN (6 x 6 mm): 8-output
 - 32-pin QFN (5 x 5 mm): 4-output
 - 20-pin QFN (3 x 3 mm): 2-output
- Pb-free, RoHS-6 compliant

2. Functional Block Diagrams

Si52212

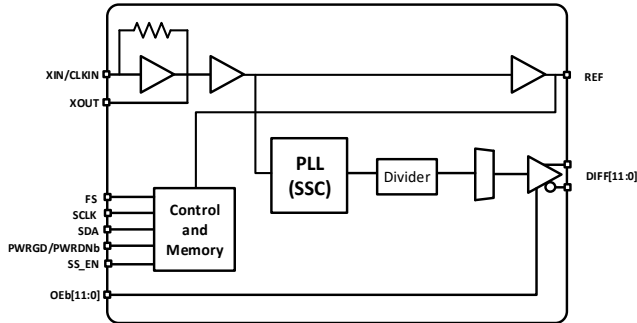

Figure 1. Si52212 Block Diagram
12-Output, 64-QFN

Si52208

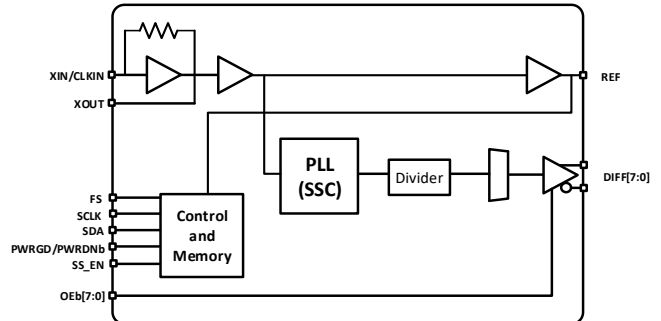

Figure 2. Si52208 Block Diagram
8-Output, 48-QFN

Si52204

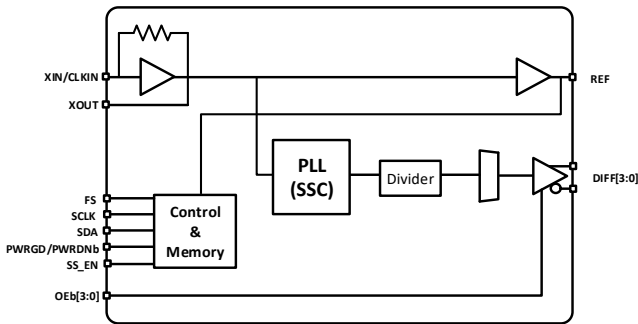

Figure 3. Si52204 Block Diagram
4-Output, 32-QFN

Si52202

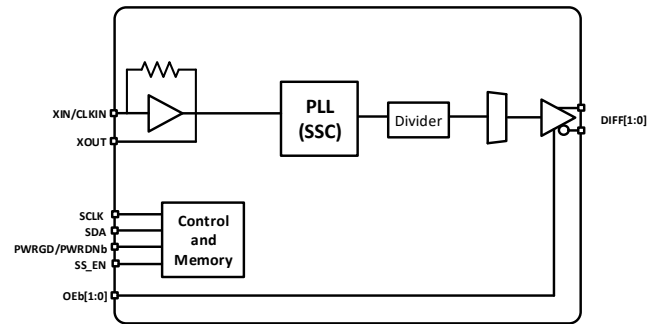

Figure 4. Si52202 Block Diagram
2-Output, 20-QFN

3. Pin Descriptions

3.1. Si52212 Pin Descriptions

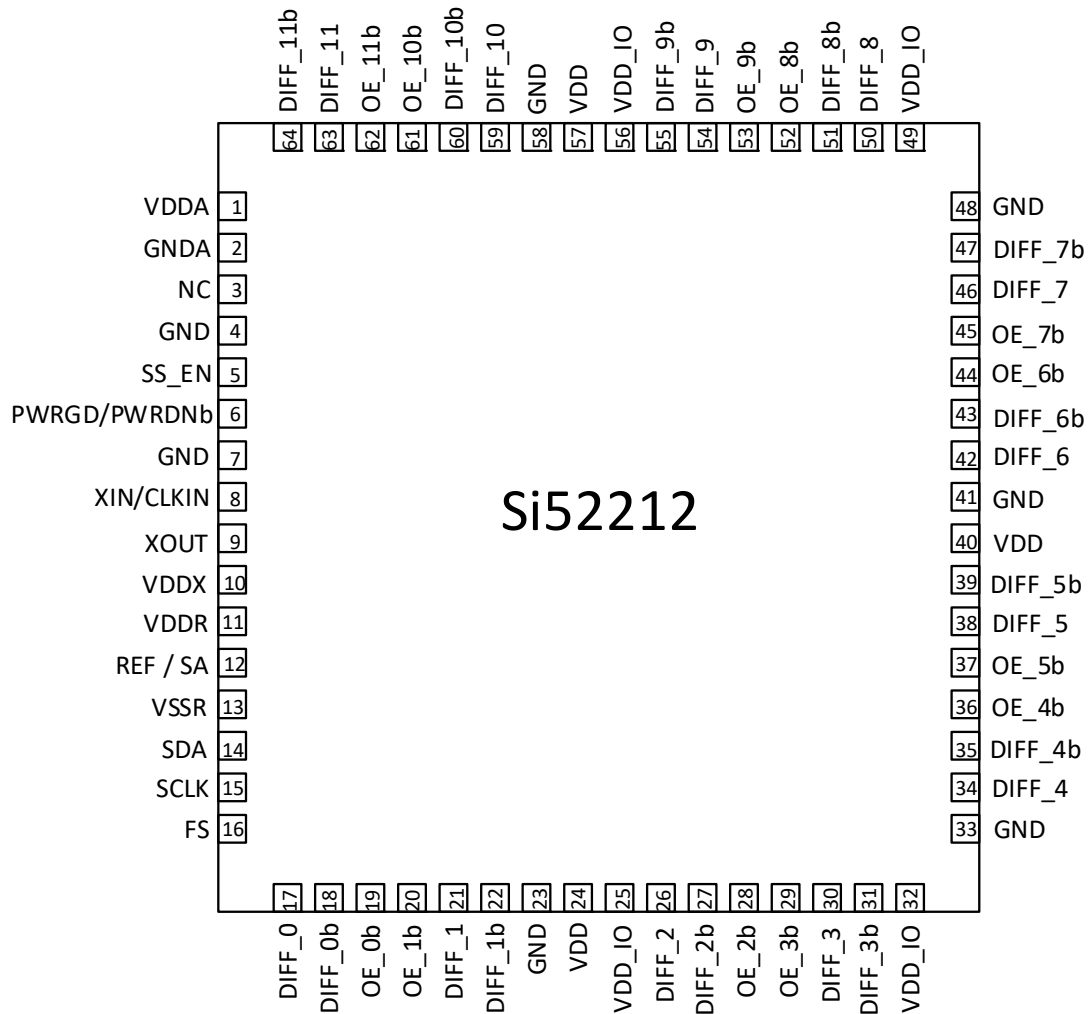

Figure 5. Si52212 64-Pin QFN Pinout

Table 1. Si52212 Signal Descriptions

Pin #	Name	Type	Description
1	VDDA	PWR	Analog power supply
2	GND	PWR	Analog ground
3	NC		No connect
4	GND	GND	Ground
5	SS_EN	I	Spread spectrum enable pin. 0 = -0.25% spread, mid = Off, 1 = -0.5% spread (This pin has an internal 100 kΩ pull-up)
6	PWRGD/ PWRDNb	I, PU	Active low input pin asserts power down (PDb) and disables all outputs (this pin has an internal 100 kΩ pull-up). Refer to settings of Byte 2, Bit2 and Bit3 for REF. Settings for Bit3 (REF_OE) will take precedence for REF.
7	GND	GND	Ground
8	XIN/CLKIN	I	25.00 MHz crystal input or 25 MHz Clock Inputs
9	XOUT	O	25.00 MHz crystal output, Float XOUT if using only CLKIN (Clock input)
10	VDDX	PWR	Power supply for crystal
11	VDDR	PWR	Power supply for REF output
12	REF /SA	O/I	REF = 25 MHz LVCMOS output. SA = Address select for I ² C. When part is powered up, SA will be latched to select the I ² C address. Refer to Table 12, "SA State on First Application of PWRDNb," on page 34. Refer also to "Feature List" on page 2 for termination (this pin has an internal 60 kΩ pull-up).
13	VSSR	GND	Ground
14	SDA	I/O	I ² C compatible SDATA
15	SCLK	I	I ² C compatible SCLOCK
16	FS	I	Frequency select pin, 0 = 100 MHz, mid = 200 MHz, 1 = 133 MHz (this pin has an internal 100 kΩ pull-down)
17	DIFF_0	O, DIF	0.7 V, 100 MHz differential clock
18	DIFF_0b	O, DIF	0.7 V, 100 MHz differential clock
19	OE_0b	I, PD	Output enable for DIFF_0 pair (this pin has an internal 100 kΩ pull-down), 0 = Enable outputs; 1 = Disable outputs
20	OE_1b	I, PD	Output enable for DIFF_1 pair (this pin has an internal 100 kΩ pull-down), 0 = Enable outputs; 1 = Disable outputs
21	DIFF_1	O, DIF	0.7 V, 100 MHz differential clock
22	DIFF_1b	O, DIF	0.7 V, 100 MHz differential clock
23	GND	GND	Ground
24	VDD	PWR	Power supply
25	VDD_IO	PWR	Output power supply
26	DIFF_2	O, DIF	0.7 V, 100 MHz differential clock
27	DIFF_2b	O, DIF	0.7 V, 100 MHz differential clock
28	OE_2b	I, PD	Output enable for DIFF_2 pair (this pin has an internal 100 kΩ pull-down), 0 = Enable outputs; 1 = Disable outputs
29	OE_3b	I, PD	Output enable for DIFF_3 pair (this pin has an internal 100 kΩ pull-down), 0 = Enable outputs; 1 = Disable outputs
30	DIFF_3	O, DIF	0.7 V, 100 MHz differential clock
31	DIFF_3b	O, DIF	0.7 V, 100 MHz differential clock
32	VDD_IO	PWR	Output power supply
33	GND	GND	Ground

Table 1. Si52212 Signal Descriptions (Continued)

Pin #	Name	Type	Description
34	DIFF_4	O, DIF	0.7 V, 100 MHz differential clock
35	DIFF_4b	O, DIF	0.7 V, 100 MHz differential clock
36	OE_4b	I, PD	Output enable for DIFF_4 pair (this pin has an internal 100 kΩ pull-down), 0 = Enable outputs; 1 = Disable outputs
37	OE_5b	I, PD	Output enable for DIFF_5 pair (this pin has an internal 100 kΩ pull-down), 0 = Enable outputs; 1 = Disable outputs
38	DIFF_5	O, DIF	0.7 V, 100 MHz differential clock
39	DIFF_5b	O, DIF	0.7 V, 100 MHz differential clock
40	VDD	PWR	Power supply
41	GND	GND	Ground
42	DIFF_6	O, DIF	0.7 V, 100 MHz differential clock
43	DIFF_6b	O, DIF	0.7 V, 100 MHz differential clock
44	OE_6b	I, PD	Output enable for DIFF_6 pair (this pin has an internal 100 kΩ pull-down), 0 = Enable outputs; 1 = Disable outputs
45	OE_7b	I, PD	Output enable for DIFF_7 pair (this pin has an internal 100 kΩ pull-down), 0 = Enable outputs; 1 = Disable outputs
46	DIFF_7	O, DIF	0.7 V, 100 MHz differential clock
47	DIFF_7b	O, DIF	0.7 V, 100 MHz differential clock
48	GND	GND	Ground
49	VDD_IO	PWR	Output power supply
50	DIFF_8	O, DIF	0.7 V, 100 MHz differential clock
51	DIFF_8b	O, DIF	0.7 V, 100 MHz differential clock
52	OE_8b	I, PD	Output enable for DIFF_8 pair (this pin has an internal 100 kΩ pull-down), 0 = Enable outputs; 1 = Disable outputs
53	OE_9b	I, PD	Output enable for DIFF_9 pair (this pin has an internal 100 kΩ pull-down), 0 = Enable outputs; 1 = Disable outputs
54	DIFF_9	O, DIF	0.7 V, 100 MHz differential clock
55	DIFF_9b	O, DIF	0.7 V, 100 MHz differential clock
56	VDD_IO	PWR	Output power supply
57	VDD	PWR	Power supply
58	GND	GND	Ground
59	DIFF_10	O, DIF	0.7 V, 100 MHz differential clock
60	DIFF_10b	O, DIF	0.7 V, 100 MHz differential clock
61	OE_10b	I, PD	Output enable for DIFF_10 pair (this pin has an internal 100 kΩ pull-down), 0 = Enable outputs; 1 = Disable outputs
62	OE_11b	I, PD	Output enable for DIFF_11 pair (this pin has an internal 100 kΩ pull-down), 0 = Enable outputs; 1 = Disable outputs
63	DIFF_11	O, DIF	0.7 V, 100 MHz differential clock
64	DIFF_11b	O, DIF	0.7 V, 100 MHz differential clock
	GND PAD	GND	The ground pad provides an electrical and thermal connection to ground and must be connected for proper operation. Use as many vias as practical, and keep the via length to an internal ground plane as short as possible.

3.2. Si52208 Pin Descriptions

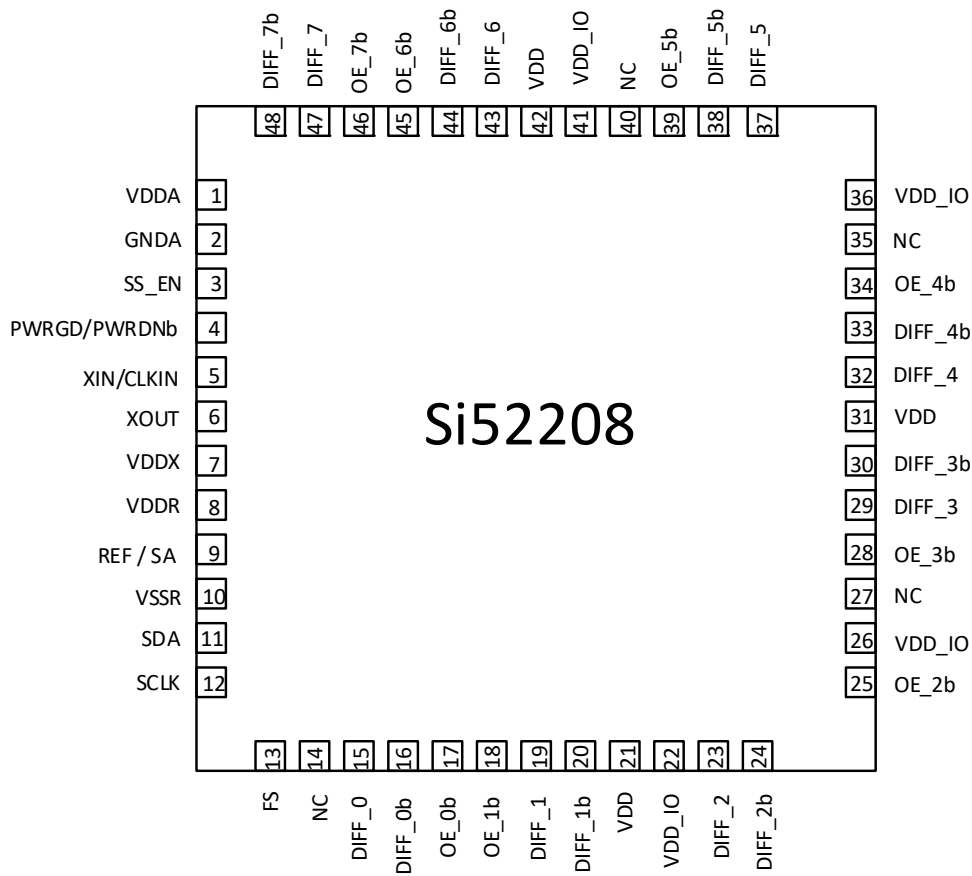

Figure 6. Si52208 48-pin QFN Pinout

Table 2. Si52208 Signal Descriptions

Pin	Name	Type	Description
1	VDDA	PWR	Analog power supply
2	GNDA	PWR	Analog ground
3	SS_EN	I	Spread spectrum enable pin. 0 = -0.25% spread, mid= Off, 1 = -0.5% spread (this pin has an internal 100 kΩ pull-up)
4	PWRGD/ PWRDNb	I, PU	Active low input pin asserts power down (PDb) and disables all outputs (this pin has an internal 100 kΩ pull-up). Refer to settings of Byte 2, Bit2 and Bit3 for REF. Settings for Bit3 (REF_OE) will take precedence for REF.
5	XIN/CLKIN	I	25.00 MHz crystal input or 25 MHz Clock Input
6	XOUT	O	25.00 MHz crystal output, float XOUT if using only CLKIN (clock input)
7	VDDX	PWR	Power supply for crystal
8	VDDR	PWR	Power supply for REF output

Table 2. Si52208 Signal Descriptions (Continued)

Pin	Name	Type	Description
9	REF /SA	O/I	REF = 25 MHz LVCMOS output. SA = Address select for I ² C. When part is powered up, SA will be latched to select the I ² C address. Refer to Table 12, "SA State on First Application of PWRDNb," on page 34. Refer also to "Feature List" on page 2 for termination (this pin has an internal 60 kΩ pull-up).
10	VSSR	GND	Power supply for crystal
11	SDA	I/O	I ² C compatible SDATA
12	SCLK	I	I ² C compatible SCLOCK
13	FS	I	Frequency select pin, 0 = 100 MHz, mid = 200 MHz, 1 = 133 MHz (this pin has an internal 100 kΩ pull-down)
14	NC	NC	No connection
15	DIFF_0	O, DIF	0.7 V, 100 MHz differential clock
16	DIFF_0b	O, DIF	0.7 V, 100 MHz differential clock
17	OE_0b	I, PD	Output enable for DIFF_0 pair (this pin has an internal 100 kΩ pull-down), 0 = Enable outputs; 1 = Disable outputs
18	OE_1b	I, PD	Output enable for DIFF_1 pair (this pin has an internal 100 kΩ pull-down), 0 = Enable outputs; 1 = Disable outputs
19	DIFF_1	O, DIF	0.7 V, 100 MHz differential clock
20	DIFF_1b	O, DIF	0.7 V, 100 MHz differential clock
21	VDD	PWR	Power supply
22	VDD_IO	PWR	Output power supply
23	DIFF_2	O, DIF	0.7 V, 100 MHz differential clock
24	DIFF_2b	O, DIF	0.7 V, 100 MHz differential clock
25	OE_2b	I, PD	Output enable for DIFF_2 pair (this pin has an internal 100 kΩ pull-down), 0 = Enable outputs; 1 = Disable outputs
26	VDD_IO	PWR	Output power supply
27	NC	NC	No connection
28	OE_3b	I, PD	Output enable for DIFF_3 pair (this pin has an internal 100 kΩ pull-down), 0 = Enable outputs; 1 = Disable outputs
29	DIFF_3	O, DIF	0.7 V, 100 MHz differential clock
30	DIFF_3b	O, DIF	0.7 V, 100 MHz differential clock
31	VDD	PWR	Power supply
32	DIFF_4	O, DIF	0.7 V, 100 MHz differential clock
33	DIFF_4b	O, DIF	0.7 V, 100 MHz differential clock
34	OE_4b	I, PD	Output enable for DIFF_4 pair (this pin has an internal 100 kΩ pull-down), 0 = Enable outputs; 1 = Disable outputs
35	NC	NC	No connection
36	VDD_IO	PWR	Output power supply
37	DIFF_5	O, DIF	0.7 V, 100 MHz differential clock
38	DIFF_5b	O, DIF	0.7 V, 100 MHz differential clock
39	OE_5b	I, PD	Output enable for DIFF_5 pair (this pin has an internal 100 kΩ pull-down), 0 = Enable outputs; 1 = Disable outputs
40	NC	NC	No connection
41	VDD_IO	PWR	Output power supply
42	VDD	PWR	Power supply
43	DIFF_6	O, DIF	0.7 V, 100 MHz differential clock

Table 2. Si52208 Signal Descriptions (Continued)

Pin	Name	Type	Description
44	DIFF_6b	O, DIF	0.7 V, 100 MHz differential clock
45	OE_6b	I, PD	Output enable for DIFF_6 pair (this pin has an internal 100 kΩ pull-down), 0 = Enable outputs; 1 = Disable outputs
46	OE_7b	I, PD	Output enable for DIFF_7 pair (This pin has an internal 100 kΩ pull-down), 0 = Enable outputs; 1 = Disable outputs
47	DIFF_7	O, DIF	0.7 V, 100 MHz differential clock
48	DIFF_7b	O, DIF	0.7 V, 100 MHz differential clock
	GND PAD	GND	The ground pad provides an electrical and thermal connection to ground and must be connected for proper operation. Use as many vias as practical, and keep the via length to an internal ground plane as short as possible.

3.3. Si52204 Pin Descriptions

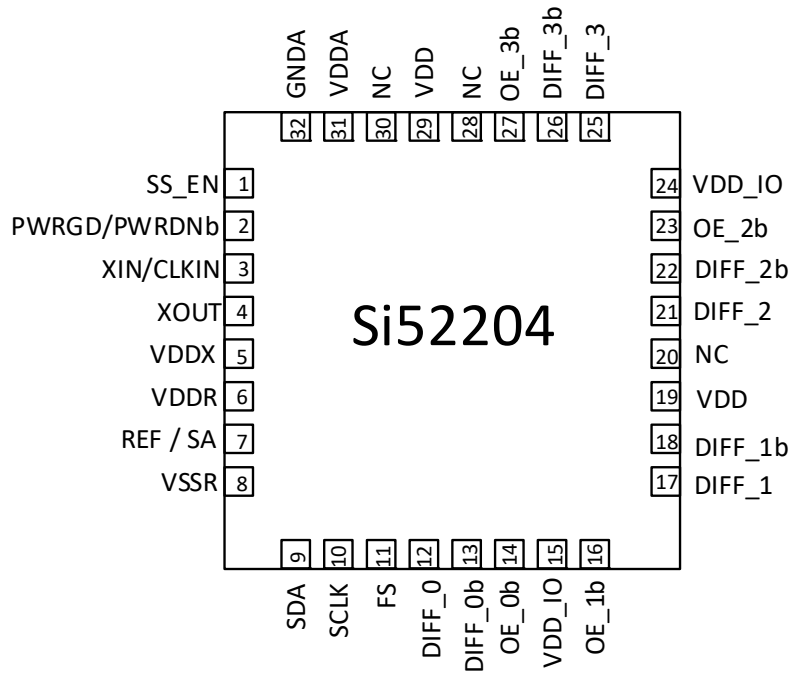

Figure 7. Si52204 32-pin QFN Pinout

Table 3. Si52204 Signal Descriptions

Pin #	Name	Type	Description
1	SS_EN	I	Spread spectrum enable pin, 0 = -0.25% spread; mid = Off; 1 = -0.5% spread (this pin has an internal 100 kΩ pull-up)
2	PWRGD/ PWRDNb	I, PU	Active low input pin asserts power down (PDb) and disables all outputs (this pin has an internal 100 kΩ pull-up). Refer to settings of Byte 2, Bit2 and Bit3 for REF. Settings for Bit3 (REF_OE) will take precedence for REF.
3	XIN/CLKIN	I	25.00 MHz crystal input or 25 MHz Clock Input
4	XOUT	O	25.00 MHz crystal output. Float XOUT if using only CLKIN (clock input)
5	VDDX	PWR	Power supply for crystal
6	VDDR	PWR	Power supply for REF output
7	REF /SA	O/I	REF = 25 MHz LVCMOS output. SA = Address select for I ² C. When part is powered up, SA will be latched to select the I ² C address. Refer to Table 12, “SA State on First Application of PWRDNb,” on page 34. Refer also to “Feature List” on page 2 for termination (this pin has an internal 60 kΩ pull-up).
8	VSSR	GND	Ground
9	SDA	I/O	I ² C compatible SDATA
10	SCLK	I	I ² C compatible SCLOCK
11	FS	I	Frequency select pin, 0 = 100 MHz; mid = 200 MHz; 1 = 133 MHz (this pin has an internal 100 kΩ pull-down)
12	DIFF_0	O, DIF	0.7 V, 100 MHz differential clock
13	DIFF_0b	O, DIF	0.7 V, 100 MHz differential clock

Table 3. Si52204 Signal Descriptions (Continued)

Pin #	Name	Type	Description
14	OE_0b	I, PD	Output enable for DIFF_0 pair (this pin has an internal 100 kΩ pull-down), 0 = Enable outputs; 1 = Disable outputs
15	VDD_IO	PWR	Output power supply
16	OE_1b	I, PD	Output enable for DIFF_1 pair (this pin has an internal 100 kΩ pull-down), 0 = Enable outputs; 1 = Disable outputs
17	DIFF_1	O, DIF	0.7 V, 100 MHz differential clock
18	DIFF_1b	O, DIF	0.7 V, 100 MHz differential clock
19	VDD	PWR	Power supply
20	NC	NC	No connection
21	DIFF_2	O, DIF	0.7 V, 100 MHz differential clock
22	DIFF_2b	O, DIF	0.7 V, 100 MHz differential clock
23	OE_2b	I, PD	Output enable for DIFF_2 pair (this pin has an internal 100 kΩ pull-down), 0 = Enable outputs; 1 = Disable outputs
24	VDD_IO	PWR	Output power supply
25	DIFF_3	O, DIF	0.7 V, 100 MHz differential clock
26	DIFF_3b	O, DIF	0.7 V, 100 MHz differential clock
27	OE_3b	I, PD	Output enable for DIFF_3 pair (this pin has an internal 100 kΩ pull-down), 0 = Enable outputs; 1 = Disable outputs
28	NC	NC	No connection
29	VDD	PWR	Power supply
30	NC	NC	No connect
31	VDDA	PWR	Analog power supply
32	GND A	PWR	Analog ground
	GND PAD	GND	The ground pad provides an electrical and thermal connection to ground and must be connected for proper operation. Use as many vias as practical, and keep the via length to an internal ground plane as short as possible.

3.4. Si52202 Pin Descriptions

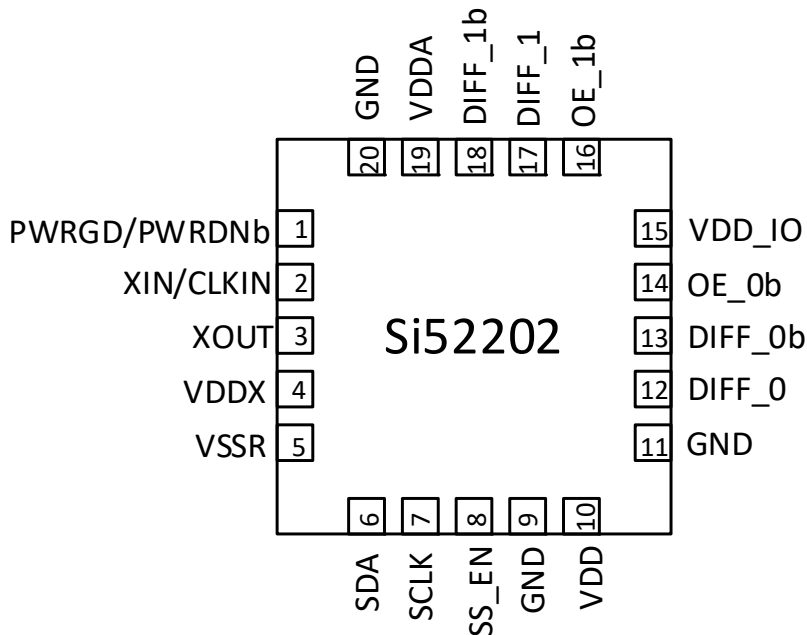

Figure 8. Si52202 20-pin QFN Pinout

Table 4. Si52202 Signal Descriptions¹

Pin #	Name	Type	Description
1	PWRGD/PWRDNb	I, PU	Active low input pin asserts power down (PDb) and disables all outputs (this pin has an internal pull-up)
2	XIN/CLKIN	I	25.00 MHz crystal input or 25 MHz Clock Input
3	XOUT	O	25.00 MHz crystal output. Float XOUT if using only CLKIN (clock input)
4	VDDX	PWR	Power supply for crystal
5	VSSR	GND	Ground
6	SDA	I/O	I ² C compatible SDATA
7	SCLK	I	I ² C compatible SCLOCK
8	SS_EN	I	Spread spectrum enable pin, 0 = -0.25% spread; mid = Off; 1 = -0.5% spread (this pin has an internal 100 kΩ pull-up)
9	GND	GND	Ground
10	VDD	PWR	Power supply
11	GND	GND	Ground
12	DIFF_0	O, DIF	0.7 V, 100 MHz differential clock
13	DIFF_0b	O, DIF	0.7 V, 100 MHz differential clock
14	OE_0b	I, PD	Output enable for DIFF_0 pair (this pin has an internal 100 kΩ pull-down), 0 = Enable outputs; 1 = Disable outputs
15	VDD_IO	PWR	Output power supply

Table 4. Si52202 Signal Descriptions¹ (Continued)

Pin #	Name	Type	Description
16	OE_1b	I, PD	Output enable for DIFF_1 pair (this pin has an internal 100 kΩ pull-down), 0 = Enable outputs; 1 = Disable outputs
17	DIFF_1	O, DIF	0.7 V, 100 MHz differential clock
18	DIFF_1b	O, DIF	0.7 V, 100 MHz differential clock
19	VDDA	PWR	Analog power supply
20	GND	GND	Ground
	GND PAD	GND	The ground pad provides an electrical and thermal connection to ground and must be connected for proper operation. Use as many vias as practical, and keep the via length to an internal ground plane as short as possible.

1. Contact factory for 133/200M output frequencies.

4. Electrical Specifications

4.1. Absolute Maximum Ratings

All minimum and maximum specifications in the following tables are assured and apply across the recommended operating conditions. Typical values apply at nominal supply voltages and an operating temperature of 25 °C, unless otherwise noted.

Table 5. Absolute Maximum Conditions^{1 2}

Parameter	Symbol	Test Condition	Min	Typ	Max	Units
Main supply voltage	$V_{DD_1.8V}$	Functional	—	—	2.5	V
Input voltage	V_{IN}	Relative to VSS	-0.5	—	VDD + 0.5	V
Input high voltage i^2c	V_{IH_I2C}	SDATA and SCLK	—	—	3.6	V
Temperature, storage	T_S	Non-functional	-65	—	150	°C
Temperature, operating ambient	T_A	Functional	-40	—	85	°C
Temperature, junction	T_J	Functional	—	—	125	°C
ESD protection (human body model)	ESDHBM	JEDEC (JESD 22-A114)	-2000	—	2000	V
Flammability rating	UL-94	UL (Class)	V-0			

1. While using multiple power supplies, the voltage on any input or I/O pin cannot exceed the power pin during power-up. Power supply sequencing is not required.
2. Exposure to maximum rating conditions for extended periods may reduce device reliability. There is no damage to device with only one parameter set at the limit and all other parameters set at or below their nominal value. Exceeding any of the limits listed here may result in permanent damage to the device.

ESD Handling: Industry-standard ESD handling precautions must be adhered to at all times to avoid damage to this device.

4.2. Thermal Characteristics

Table 6. Thermal Conditions

Parameter	Symbol	Test Condition	Value	Units
Si52202 - 20-QFN¹				
Thermal resistance, junction to ambient	θ_{JA}	Still Air Air Flow 1 m/s Air Flow 2 m/s	60 56 54.4	°C/W
Thermal resistance, junction to case	θ_{JC}		10.8	°C/W
Thermal resistance, junction to board	θ_{JB}		34.1	°C/W
Thermal resistance, junction to top center	ψ_{JT}		3.1	°C/W
Thermal resistance, junction to board	ψ_{JB}		33.9	°C/W
Si52204 - 32-QFN²				
Thermal resistance, junction to ambient	θ_{JA}	Still Air Air Flow 1 m/s Air Flow 2 m/s	50.3 47 45.6	°C/W
Thermal resistance, junction to case	θ_{JC}		10.3	°C/W
Thermal resistance, junction to board	θ_{JB}		30.9	°C/W
Thermal resistance, junction to top center	ψ_{JT}		2.3	°C/W
Thermal resistance, junction to board	ψ_{JB}		30.9	°C/W
Si52208 - 48-QFN³				
Thermal resistance, junction to ambient	θ_{JA}	Still Air Air Flow 1 m/s Air Flow 2 m/s	27.9 24.5 23.5	°C/W
Thermal resistance, junction to case	θ_{JC}		17	°C/W
Thermal resistance, junction to board	θ_{JB}		13.4	°C/W
Thermal resistance, junction to top center	ψ_{JT}		0.5	°C/W
Thermal resistance, junction to board	ψ_{JB}		13.1	°C/W
Si52212 - 64-QFN⁴				
Thermal resistance, junction to ambient	θ_{JA}	Still Air Air Flow 1 m/s Air Flow 2 m/s	27.2 23.9 22.5	°C/W
Thermal resistance, junction to case	θ_{JC}		13.7	°C/W
Thermal resistance, junction to board	θ_{JB}		14.4	°C/W
Thermal resistance, junction to top center	ψ_{JT}		0.5	°C/W
Thermal resistance, junction to board	ψ_{JB}		14.2	°C/W

1. Based on a 4 layer, PCB with Dimension 3" x 4.5". PCB Thickness of 1.6mm. PCB Center Land with 4 Via to top plane.
2. Based on PCB with dimension 3" x 4.5", PCB Thickness of 1.6 mm. PCB Center Land with 4 Via to top plane.
3. Based on 4 layer PCB with dimension 3" x 4.5", PCB Thickness of 1.6 mm. PCB Center Land with 9 Via to top plane.
4. Based on 4 Layer PCB with dimension 3" x 4.5", PCB Thickness of 1.6 mm. PCB Center Land with 25 Via to top plane.

4.3. Electrical Characteristics

Table 7. DC Electrical Specifications
($V_{DD} = V_{DDR} = V_{DDX} = V_{DDA} = 1.5\text{ V} \pm 5\%$)

Parameter	Symbol	Test Condition	Min	Typ	Max	Unit
1.5 V Operating voltage	VDD	1.5 V $\pm 5\%$	1.425	1.5	1.575	V
Output supply voltage	VDD_IO	Supply voltage for differential Low Power outputs	0.9975	1.05–1.5	1.575	V
1.5 V Input high voltage	V _{IH}	Control input pins, except SDATA, SCLK	0.75 VDD	—	VDD + 0.3	V
1.5 V Input mid voltage	V _{IM}	Tri-level control input pins, except SDATA, SCLK	0.4 VDD	0.5 VDD	0.6 VDD	V
1.5 V Input low voltage	V _{IL}	Control input pins, except SDATA, SCLK	–0.3	—	0.25 VDD	V
Input high voltage	V _{IHI2C}	SDATA, SCLK	1.14	—	3.3	V
Input low voltage	V _{ILI2C}	SDATA, SCLK	—	—	0.6	V
SDATA, SCLK sink current	I _{PULLUP}	At V _{OL}	4	—	—	mA
Input current	I _{IN}	Single-ended inputs, V _{IN} = GND, V _{IN} = VDD	–5	—	5	μ A
	I _{INP}	Single-ended inputs, V _{IN} = 0 V, inputs with internal pull-up resistors V _{IN} = VDD, inputs with internal pull-down resistors	–200	—	200	μ A
Input pin capacitance	C _{IN}		1.5	—	5	pF
Output pin capacitance	C _{OUT}		—	—	6	pF
Pin inductance	L _{IN}		—	—	7	nH
Si52212 Current Consumption (VDD = VDDR = VDDX = VDDA = 1.5 V $\pm 5\%$)						
Power down current PWRGD/ PWRDNb = “0” Byte 2, bit 2 = 0	I _{DD_PD_total}	All outputs off	—	1.3	1.8	mA
	I _{DD_PD}	VDD, except VDDA and VDD_IO, all outputs off	—	0.4	1.0	mA
	I _{DD_APD}	VDDA, all outputs off	—	0.6	0.75	mA
	I _{DD_IOPD}	VDD_IO, all outputs off	—	0.3	0.5	mA
Wake-on LAN current PWRGD_PWRDNb = “0” Byte 2, bit 2 = 1	I _{DD_WOL}	VDD, except VDDA and VDD_IO, all differential outputs off, REF running	—	2.5	3.2	mA
	I _{DD_AWOL}	VDDA, all differential outputs off, REF running	—	0.6	0.75	mA
	I _{DD_IOWOL}	VDD_IO, all differential outputs off, REF running	—	0.3	0.5	mA
Dynamic supply current	I _{DD_1.5V_Total}	All outputs enabled. Differential clocks with 5” traces and 2 pF load.	—	66	77	mA
	I _{DD_OP}	VDD, except VDDA and VDD_IO, all differential outputs active at 100 MHz	—	13	14.5	mA
	I _{DD_AOP}	VDDA, all differential outputs active at 100 MHz	—	7	8.5	mA
	I _{DD_IOOP}	VDD_IO, all differential outputs active at 100 MHz	—	46	55.5	mA

Table 7. DC Electrical Specifications (Continued)

(V_{DD} = V_{DDR} = V_{DDX} = V_{VDDA} = 1.5 V ±5%)

Parameter	Symbol	Test Condition	Min	Typ	Max	Unit
Si52208 Current Consumption (VDD = VDDR = VDDX = VDDA = 1.5 V ±5%)						
Power down current PWRGD/ PWRDNb = "0" Byte 2, bit 2 = 0	I _{DD_PD_total}	All outputs off	—	1.3	1.8	mA
	I _{DD_PD}	VDD, except VDDA and VDD_IO, all outputs off	—	0.4	1.0	mA
	I _{DD_APD}	VDDA, all outputs off	—	0.6	0.75	mA
	I _{DD_IOPD}	VDD_IO, all outputs off	—	0.3	0.5	mA
Wake-on LAN current PWRGD_PWRDNb = "0" Byte 2, bit 2 = 1	I _{DD_WOL}	VDD, except VDDA and VDD_IO, all differential outputs off, REF running	—	2.5	3.2	mA
	I _{DD_AWOL}	VDDA, all differential outputs off, REF running	—	0.6	0.75	mA
	I _{DD_IOWOL}	VDD_IO, all differential outputs off, REF running	—	0.3	0.5	mA
Dynamic supply current	I _{DD_1.5V_Total}	All outputs enabled. Differential clocks with 5" traces and 2 pF load.	—	48	58.5	mA
	I _{DD_OP}	VDD, except VDDA and VDD_IO, all differential outputs active at 100 MHz	—	11	12.5	mA
	I _{DD_AOP}	VDDA, all differential outputs active at 100 MHz	—	7	8.5	mA
	I _{DD_IOOP}	VDD_IO, all differential outputs active at 100 MHz	—	30	37.5	mA
Si52204 Current Consumption (VDD = VDDR = VDDX = VDDA = 1.5 V ±5%)						
Power down current PWRGD/ PWRDNb = "0" Byte 2, bit 2 = 0	I _{DD_PD_total}	All outputs off	—	1.3	1.8	mA
	I _{DD_PD}	VDD, except VDDA and VDD_IO, all outputs off	—	0.4	1.0	mA
	I _{DD_APD}	VDDA, all outputs off	—	0.6	0.75	mA
	I _{DD_IOPD}	VDD_IO, all outputs off	—	0.3	0.5	mA
Wake-on LAN current PWRGD_PWRDNb = "0" Byte 2, bit 2 = 1	I _{DD_WOL}	VDD, except VDDA and VDD_IO, all differential outputs off, REF running	—	2.5	3.2	mA
	I _{DD_AWOL}	VDDA, all differential outputs off, REF running	—	0.6	0.75	mA
	I _{DD_IOWOL}	VDD_IO, all differential outputs off, REF running	—	0.3	0.5	mA
Dynamic supply current	I _{DD_1.5V_Total}	All outputs enabled. Differential clocks with 5" traces and 2 pF load.	—	32	37	mA
	I _{DD_OP}	VDD, except VDDA and VDD_IO, all differential outputs active at 100 MHz	—	9.5	11	mA
	I _{DD_AOP}	VDDA, all differential outputs active at 100 MHz	—	7	8.5	mA
	I _{DD_IOOP}	VDD_IO, all differential outputs active at 100 MHz	—	15.5	19	mA

Table 7. DC Electrical Specifications (Continued)

($V_{DD} = V_{DDR} = V_{DDX} = V_{DDA} = 1.5\text{ V} \pm 5\%$)

Parameter	Symbol	Test Condition	Min	Typ	Max	Unit
Si52202 Current Consumption ($V_{DD} = V_{DDR} = V_{DDX} = V_{DDA} = 1.5\text{ V} \pm 5\%$)						
Power down current PWRGD/ PWRDNb = "0"	$I_{DD_PD_total}$	All outputs off	—	1.3	1.8	mA
	I_{DD_PD}	VDD, except VDDA and VDD_IO, all outputs off	—	0.4	1.0	mA
	I_{DD_APD}	VDDA, all outputs off	—	0.3	0.75	mA
	I_{DD_IOPD}	VDD_IO, all outputs off	—	0.6	0.5	mA
Dynamic supply current	$I_{DD_1.5V_Total}$	All outputs enabled. Differential clocks with 5" traces and 2 pF load.	—	22	25.5	mA
	I_{DD_OP}	VDD, except VDDA and VDD_IO, all differential outputs active at 100 MHz	—	7	8	mA
	I_{DD_AOP}	VDDA, all differential outputs active at 100 MHz	—	7	8.5	mA
	I_{DD_IOOP}	VDD_IO, all differential outputs active at 100 MHz	—	8	10	mA

Table 8. DC Electrical Specifications

($V_{DD} = V_{DDR} = V_{DDX} = V_{DDA} = 1.8\text{ V} \pm 5\%$)

Parameter	Symbol	Test Condition	Min	Typ	Max	Unit
1.8 V Operating voltage	VDD	1.8 V $\pm 5\%$	1.71	1.8	1.89	V
Output supply voltage	VDD_IO	Supply voltage for differential Low Power outputs	0.9975	1.05 to 1.8	1.9	V
1.8 V Input high voltage	V_{IH}	Control input pins, except SDATA, SCLK	0.75 V_{DD}	—	VDD+0.3	V
1.8 V Input mid voltage	V_{IM}	Tri-level control input pins, except SDATA, SCLK	0.4 V_{DD}	0.5 V_{DD}	0.6 VDD	V
1.8 V Input low voltage	V_{IL}	Control input pins, except SDATA, SCLK	-0.3	—	0.25 VDD	V
Input high voltage	V_{IH12C}	SDATA, SCLK	1.11	—	3.3	V
Input low voltage	V_{IL12C}	SDATA, SCLK	—	—	0.6	V
SDATA, SCLK sink current	I_{PULLUP}	At VOL	4	—	—	mA
Input current	I_{IN}	Single-ended inputs, VIN = GND, VIN = VDD	-5	—	5	uA
	I_{INP}	Single-ended inputs, VIN = 0 V, inputs with internal pull-up resistors VIN = VDD, inputs with internal pull-down resistors	-200	—	200	uA
Input pin capacitance	C_{IN}		1.5	—	5	pF
Output pin capacitance	C_{OUT}		—	—	6	pF
Pin inductance	L_{IN}		—	—	7	nH
Si52212 Current Consumption ($V_{DD} = V_{DDR} = V_{DDX} = V_{DDA} = 1.8\text{ V} \pm 5\%$)						
Power down current PWRGD/PWRDNb = "0" Byte 2, bit 2 = 0	$I_{DD_PD_total}$	All outputs off	—	1.4	2.9	mA
	I_{DD_PD}	VDD, except VDDA and VDD_IO, all outputs off	—	0.5	2.0	mA
	I_{DD_APD}	VDDA, all outputs off	—	0.6	0.9	mA
	I_{DD_IOPD}	VDD_IO, all outputs off	—	0.3	0.65	mA

Table 8. DC Electrical Specifications (Continued)

(V_{DD} = V_{DDR} = V_{DDX} = V_{DDA} = 1.8 V ±5%)

Parameter	Symbol	Test Condition	Min	Typ	Max	Unit
Wake-on LAN current PWRGD/PWRDNb = "0" Byte 2, bit 2 = 1	I _{DD_WOL}	VDD, except VDDA and VDD_IO, all differential outputs off, REF running	—	3.0	4.6	mA
	I _{DD_AWOL}	VDDA, all differential outputs off, REF running	—	0.7	0.9	mA
	I _{DD_IOWOL}	VDD_IO, all differential outputs off, REF running	—	0.5	0.65	mA
Dynamic supply current	I _{DD_1.8V_Total}	All outputs enabled. Differential clocks with 5" traces and 2 pF load.	—	67	78	mA
	I _{DD_OP}	VDD, except VDDA and VDD_IO, all differential outputs active at 100 MHz	—	13	16	mA
	I _{DD_AOP}	VDDA, all differential outputs active at 100 MHz	—	7	8.5	mA
	I _{DD_IOOP}	VDD_IO, all differential outputs active at 100 MHz	—	47	56.5	mA
Si52208 Current Consumption (VDD = VDDR = VDDX = VDDA = 1.8 V ±5%)						
Power down current PWRGD/ PWRDNb = "0" Byte 2, bit 2 = 0	I _{DD_PD_total}	All outputs off	—	1.4	2.9	mA
	I _{DD_PD}	VDD, except VDDA and VDD_IO, all outputs off	—	0.5	2.0	mA
	I _{DD_APD}	VDDA, all outputs off	—	0.6	0.9	mA
	I _{DD_IOPD}	VDD_IO, all outputs off	—	0.3	0.65	mA
Wake-on LAN current PWRGD/ PWRDNb = "0" Byte 2, bit 2 = 1	I _{DD_WOL}	VDD, except VDDA and VDD_IO, all differential outputs off, REF running	—	3.0	4.6	mA
	I _{DD_AWOL}	VDDA, all differential outputs off, REF running	—	0.7	0.9	mA
	I _{DD_IOWOL}	VDD_IO, all differential outputs off, REF running	—	0.5	0.65	mA
Dynamic supply current	I _{DD_1.8V_Total}	All outputs enabled. Differential clocks with 5" traces and 2 pF load.	—	49.5	58.5	mA
	I _{DD_OP}	VDD, except VDDA and VDD_IO, all differential outputs active at 100 MHz	—	11.5	14	mA
	I _{DD_AOP}	VDDA, all differential outputs active at 100 MHz	—	7	8.5	mA
	I _{DD_IOOP}	VDD_IO, all differential outputs active at 100 MHz	—	31	38	mA
Si52204 Current Consumption (VDD = VDDR = VDDX = VDDA = 1.8 V ±5%)						
Power down current PWRGD/ PWRDNb = "0" Byte 2, bit 2 = 0	I _{DD_PD_total}	All outputs off	—	1.4	2.9	mA
	I _{DD_PD}	VDD, except VDDA and VDD_IO, all outputs off	—	0.5	2.0	mA
	I _{DD_APD}	VDDA, all outputs off	—	0.6	0.9	mA
	I _{DD_IOPD}	VDD_IO, all outputs off	—	0.3	0.65	mA
Wake-on LAN current PWRGD/ PWRDNb = "0" Byte 2, bit 2 = 1	I _{DD_WOL}	VDD, except VDDA and VDD_IO, all differential outputs off, REF running	—	3.0	4.6	mA
	I _{DD_AWOL}	VDDA, all differential outputs off, REF running	—	0.7	0.9	mA
	I _{DD_IOWOL}	VDD_IO, all differential outputs off, REF running	—	0.5	0.65	mA
Dynamic supply current	I _{DD_1.8V_Total}	All outputs enabled. Differential clocks with 5" traces and 2 pF load.	—	33	38	mA
	I _{DD_OP}	VDD, except VDDA and VDD_IO, all differential outputs active at 100 MHz	—	10	12	mA
	I _{DD_AOP}	VDDA, all differential outputs active at 100 MHz	—	7	8.5	mA
	I _{DD_IOOP}	VDD_IO, all differential outputs active at 100 MHz	—	16	19.5	mA

Table 8. DC Electrical Specifications (Continued)

($V_{DD} = V_{DDR} = V_{DDX} = V_{DDA} = 1.8\text{ V} \pm 5\%$)

Parameter	Symbol	Test Condition	Min	Typ	Max	Unit
Si52202 Current Consumption ($V_{DD} = V_{DDR} = V_{DDX} = V_{DDA} = 1.8\text{ V} \pm 5\%$)						
Power down current PWRGD/ PWRDNb = "0"	$I_{DD_PD_total}$	All outputs off	—	1.4	2.9	mA
	I_{DD_PD}	VDD, except VDDA and VDD_IO, all outputs off	—	0.5	2.0	mA
	I_{DD_APD}	VDDA, all outputs off	—	0.6	0.9	mA
	I_{DD_IOPD}	VDD_IO, all outputs off	—	0.3	0.65	mA
Dynamic supply current	$I_{DD_1.8V_Total}$	All outputs enabled. Differential clocks with 5" traces and 2 pF load.	—	24	26.5	mA
	I_{DD_OP}	VDD, except VDDA and VDD_IO, all differential outputs active at 100 MHz	—	8	9	mA
	I_{DD_AOP}	VDDA, all differential outputs active at 100 MHz	—	7	8.5	mA
	I_{DD_IOOP}	VDD_IO, all differential outputs active at 100 MHz	—	8	10.5	mA

Table 9. AC Electrical Specifications

Parameter	Symbol	Test Condition	Min	Typ	Max	Unit
Clock Input						
CLKIN frequency			—	25	—	MHz
CLKIN duty cycle	T_{DC}	Measured at $V_{DD}/2$	45	—	55	%
CLKIN rising and falling slew rate	T_R/T_F	Measured between 0.2 V_{DD} and 0.8 V_{DD}	0.5	—	4	V/ns
Input high voltage	V_{IH}	XIN/CLKIN pin	$0.75 V_{DD}$	—	—	V
Input low voltage	V_{IL}	XIN/CLKIN pin	—	—	$0.25 V_{DD}$	V
Input common mode	V_{COM}	Common mode input voltage	300	—	1000	mV
Input amplitude	V_{SWING}	Peak-to-peak value	300	—	1450	mV
Control Input Pins						
Trise	T_r	Rise time of single-ended control inputs	—	—	5	ns
Tfall	T_f	Fall time of single-ended control inputs	—	—	5	ns
SDATA, SCLK rise time	T_{r12C}	(Max $V_{IL} - 0.15$) to (Min $V_{IH} + 0.15$)	—	—	1000	ns
SDATA, SCLK fall time	T_{f12C}	(Min $V_{IH} + 0.15$) to (Max $V_{IL} - 0.15$)	—	—	300	ns
I ² C operating frequency	F_{maxI^2C}	Maximum I ² C operating frequency	—	—	400	kHz
LVC MOS – REF ($V_{DD} = 1.5\text{ V} \pm 5\%$)						
Long accuracy	ppm	Variation from reference frequency	0			ppm
Clock period	T_{PERIOD}	25 MHz output	—	40	—	ns

Table 9. AC Electrical Specifications (Continued)

Parameter	Symbol	Test Condition	Min	Typ	Max	Unit
Slew rate	T_{rf}	Byte 2[1:0] = 48 (Slowest), 20% to 80% of VDDREF	—	0.5	1.0	V/ns
		Byte 2[1:0] = 49 (Slow), 20% to 80% of VDDREF	—	0.7	1.3	V/ns
		Byte 2[1:0] = 4A (Fast), 20% to 80% of VDDREF	—	0.9	1.5	V/ns
		Byte 2[1:0] = 4B (Fastest), 20% to 80% of VDDREF	—	0.9	1.6	V/ns
Duty cycle ¹	T_{DC_REF}	$V_T = V_{DD}/2$ V	45	50	55	%
Cycle-to-cycle jitter	T_{CCJ_REF}	$V_T = V_{DD}/2$ V using "SLOW" Setting	—	40	70	ps
Phase jitter	RMS_{REF}	12 kHz to 5 MHz	—	0.35	0.45	ps
REF noise floor	T_{J1kHz_REF}	1 kHz offset	—	-132	-124	dBc/Hz
REF noise floor	T_{J10kHz_REF}	10 kHz offset to Nyquist	—	-145	-138	dBc/Hz
LVC MOS – REF ($V_{DD} = 1.8$ V $\pm 5\%$)						
Long accuracy	ppm	Variation from reference frequency	0			ppm
Clock period	T_{PERIOD}	25 MHz output	—	40	—	ns
Slew rate	T_{rf}	Byte 2[1:0] = 48 (Slowest), 20% to 80% of VDDREF	—	0.7	1.3	V/ns
		Byte 2[1:0] = 49 (Slow), 20% to 80% of VDDREF	—	1.0	1.6	V/ns
		Byte 2[1:0] = 4A (Fast), 20% to 80% of VDDREF	—	1.1	1.9	V/ns
		Byte 2[1:0] = 4B (Fastest), 20% to 80% of VDDREF	—	1.2	2.0	V/ns
Duty cycle ¹	T_{DC_REF}	$V_T = V_{DD}/2$ V	45	50	55	%
Cycle-to-cycle jitter	T_{CCJ_REF}	$V_T = V_{DD}/2$ V using "SLOW" Setting	—	30	50	ps
Phase jitter	RMS_{REF}	12 kHz to 5 MHz	—	0.3	0.4	ps
REF noise floor	T_{J1kHz_REF}	1 kHz offset	—	-132	-124	dBc
REF noise floor	T_{J10kHz_REF}	10 kHz offset to Nyquist	—	-145	-139	dBc
DIFF HCSL						
Duty cycle	T_{DC}	Measured at 0 V differential	45	50	55	%
Output-to-output skew	T_{SKEW}	Measured at 0 V differential	—	10	50	ps
Slew rate	T_R/T_F	Measured differentially from ± 150 mV (fast setting)	—	2.4	3.7	V/ns
		Measured differentially from ± 150 mV (slow setting)	—	1.9	2.9	V/ns
Slew rate matching	$\Delta T_R/T_F$		—	2	10	%
Max modulation frequency df/dt	$T_{max-freqmod-slew}$		—	—	1250	ppm/ μ sec
Voltage high	V_{HIGH}		600	—	850	mV
Voltage low	V_{LOW}		-150	—	150	mV
Max voltage	V_{MAX}		—	750	1150	mV
Min voltage	V_{MIN}		-300	0	—	mV
Crossing point voltage	V_{OX}	Absolute crossing point voltage at 0.7 V Swing	250	—	550	mV
Crossing point voltage (var)	V_{OX_DELTA}	Variation of VOX over all rising clock edges	—	35	70	mV
Modulation frequency	F_{MOD}		30	31.5	33	kHz

Table 9. AC Electrical Specifications (Continued)

Parameter	Symbol	Test Condition	Min	Typ	Max	Unit
Enable/Disable and Setup						
Clock stabilization from power-up	T _{STABLE}	Min ramp rate 200 V/s	—	1	5	ms
OE_b latency	T _{OEBLAT}	Differential outputs start after OE_b assertion differential outputs stop after OE_b deassertion	—	2	3.5	clocks
PWRDNb latency to differential outputs enable	T _{PWRDNb}	Differential outputs enable after PD_b deassertion	—	490	520	μs

1. This is for XTAL mode only. For CLKIN mode, there would be a duty cycle distortion spec of ±0.5 ns.

Table 10. PCIe and Intel QPI Jitter Specifications

Parameter	Condition	Min	Typ	Max	Jitter Limit	Unit
100 MHz PCIe common-clock jitter performance	PCIe Gen 1 (2.5 GT/s)	—	25	33	86	ps (pk-pk)
	PCIe Gen 2 Hi Band (5.0 GT/s)	—	1.4	1.7	3.1	ps (RMS)
	PCIe Gen 2 Lo Band (5.0 GT/s)	—	0.18	0.24	3	ps (RMS)
	PCIe Gen 3 (8 GT/s)	—	0.3	0.38	1	ps (RMS)
	PCIe Gen 4 (16 GT/s)	—	0.3	0.38	0.5	ps (RMS)
	PCIe Gen 5 (32 GT/s) ¹	—	0.11	0.135	0.15	ps (RMS)
	PCIe Gen 6 (64 GT/s) ²	—	0.066	0.085	0.1	ps (RMS)
	PCIe Gen 7 (128 GT/s) ³	—	0.04	0.058	0.067	ps (RMS)
100 MHz PCIe separate reference clock jitter performance ⁴	PCIe Gen 3 (8 GT/s)	—	0.37	0.44	0.7	ps (RMS)
	PCIe Gen 4 (16 GT/s)	—	0.38	0.45	0.5	ps (RMS)
	PCIe Gen 5 (32 GT/s) ¹	—	0.11	0.13	0.18	ps (RMS)
	PCIe Gen 6 (64 GT/s) ²	—	0.087	0.105	0.106	ps (RMS)
	PCIe Gen 7 (128 GT/s) ³	—	0.055	0.07	0.071	ps (RMS)
PSNR⁵						
Spurs induced by external power supply noise on VDDA, 100 mVpp ripple, 1.8 V ³	100 kHz	—	-63.4	—	—	dBc
	200 kHz	—	-61.5	—	—	dBc
	300 kHz	—	-59.1	—	—	dBc
	500 kHz	—	-54.5	—	—	dBc
	1 MHz	—	-50.4	—	—	dBc
Spurs induced by external power supply noise on VDDA, 100 mVpp ripple, 1.5 V ³	100 kHz	—	-65.9	—	—	dBc
	200 kHz	—	-63.9	—	—	dBc
	300 kHz	—	-60.3	—	—	dBc
	500 kHz	—	-53.5	—	—	dBc
	1 MHz	—	-46.0	—	—	dBc

Table 10. PCIe and Intel QPI Jitter Specifications (Continued)

Parameter	Condition	Min	Typ	Max	Jitter Limit	Unit
Intel QPI Specifications for 100 MHz and 133 MHz						
Intel QPI and SMI REFCLK accumulated jitter ^{6,7}	8 Gb/s, 100 MHz, 12UI	—	0.13	0.22	0.3	ps (RMS)
Intel QPI and SMI REFCLK accumulated jitter ^{6,7}	9.6 Gb/s, 100 MHz, 12UI	—	0.11	0.19	0.2	ps (RMS)
Intel QPI and SMI REFCLK accumulated jitter ^{6,7}	6.4 Gb/s, 100/133 MHz, 12UI, 7.8M	—	0.15	0.35	0.5	ps (RMS)

1. Based on PCI Express® Base Specifications Revision 5.0 Version 1.0.
2. Based on PCI Express® Base Specifications Revision 6.0 Version 1.0.
3. Based on PCI Express® Base Specifications Revision 7.0 Version 1.0.
4. The SRIS jitter limit is the system RefClk simulation budget divided by sqrt (2) for equal allocation of uncorrelated jitter between two clocks.
5. For PSNR testing methodology, see “AN491: Power Supply Rejection for Low-Jitter Clocks”.
6. Post processed evaluation through Intel supplied Matlab scripts.
7. Measuring on 100 MHz output using the template file in the PCIe Jitter Tool.

5. Functional Description

5.1. Crystal Recommendations

The clock device requires a parallel resonance crystal.

Table 11. Crystal Recommendations

Frequency (Fund)	Cut	Loading	Load Cap	Shunt Cap (Max)	Motional (Max)	Tolerance (Max)	Stability (Max)	Aging (Max)
25 MHz	AT	Parallel	8 to 15 pF	5 pF	0.016 pF	35 ppm	30 ppm	5 ppm

5.2. Crystal Loading

Crystal loading is critical in achieving low ppm performance. To realize low ppm performance, use the total capacitance the crystal sees to calculate the appropriate capacitive loading (CL).

The figure below shows a typical crystal configuration using the two trim capacitors. It is important that the trim capacitors are in series with the crystal.

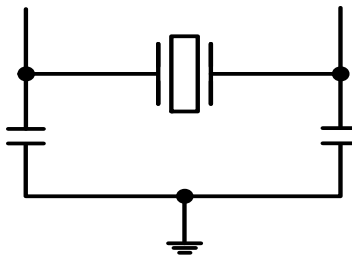

Figure 9. Crystal Capacitive Clarification

5.3. Calculating Load Capacitors

In addition to the standard external trim capacitors, consider the trace capacitance and pin capacitance to calculate the crystal loading correctly. The total capacitance on both sides is twice the specified crystal load capacitance (CL). Trim capacitors are calculated to provide equal capacitive loading on both sides.

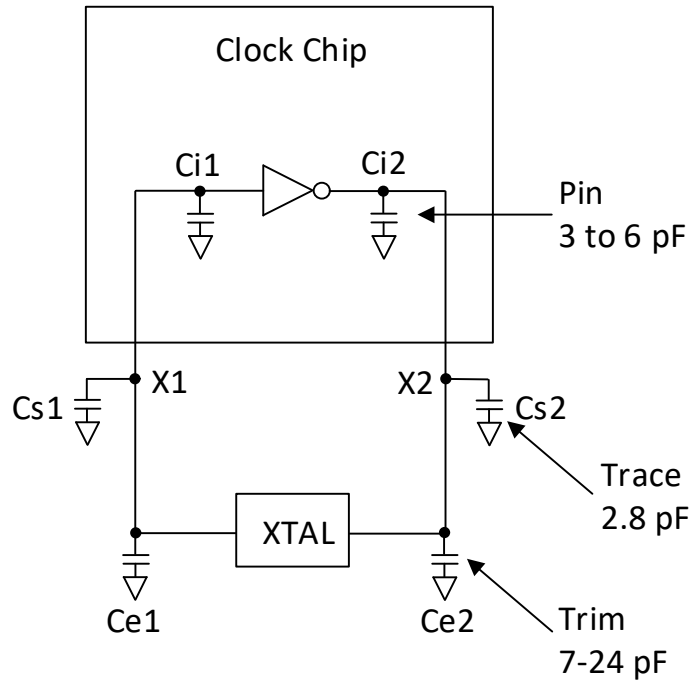

Figure 10. Crystal Loading Example

Use the following formulas to calculate the trim capacitor values for C_{e1} and C_{e2} :

Load Capacitance (Each Side)

$$C_e = 2 \times CL - (C_s + C_i)$$

Total Capacitance (As Seen by the Crystal)

$$CL_e = \frac{1}{\left(\frac{1}{C_e + C_{s1} + C_{i1}} + \frac{1}{C_{e2} + C_{s2} + C_{i2}} \right)}$$

- CL: Crystal load capacitance
- CL_e: Actual loading seen by crystal using standard value trim capacitors
- C_e: External trim capacitors
- C_s: Stray capacitance (terraced)
- C_i: Internal capacitance (lead frame, bond wires, etc.)

5.4. Power Supply Filtering Recommendations

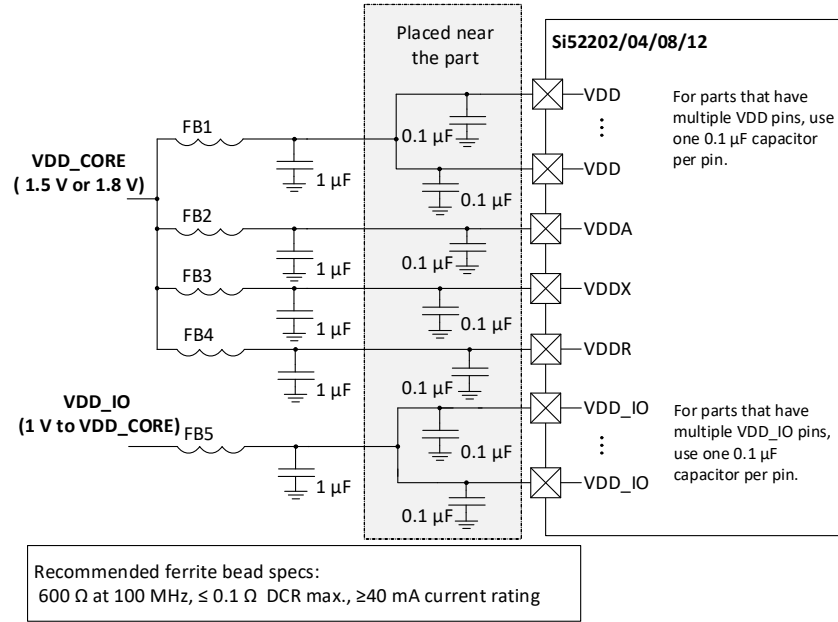

Figure 11. Power Supply Filtering

Separate out each type of VDD (VDD, VDDA, VDDX, VDDR, and VDD_IO) using ferrite beads. Then, for each VDD type use one 1 μF bulk capacitor along with an additional 0.1 μF capacitor for each individual VDD pin. All VDD Core (VDD, VDDA, VDDX, and VDDR) pins should be tied to the same voltage, either 1.8 V or 1.5 V. The VDD_IO pins can be tied to a voltage between 1 V and the selected VDD Core voltage. Note, the VDD_IO pins must all be tied to the same voltage.

5.5. PWRGD/PWRDNb (Power Down) Pin

The PWRGD/PWRDNb pin is a dual-function pin. During initial power up, the pin functions as the PWRGD pin. Upon the first power up, if the PWRGD pin is low, all outputs, the crystal oscillator, and the I²C logics will be disabled. Once the PWRGD pin has been sampled high by the clock chip, the pin assumes a PWRDNb functionality. When the pin has assumed a PWRDNb functionality and is pulled low, the device will be placed in power down mode. The assertion and deassertion of PWRDNb is asynchronous. This pin has a 100 kΩ internal pull-up.

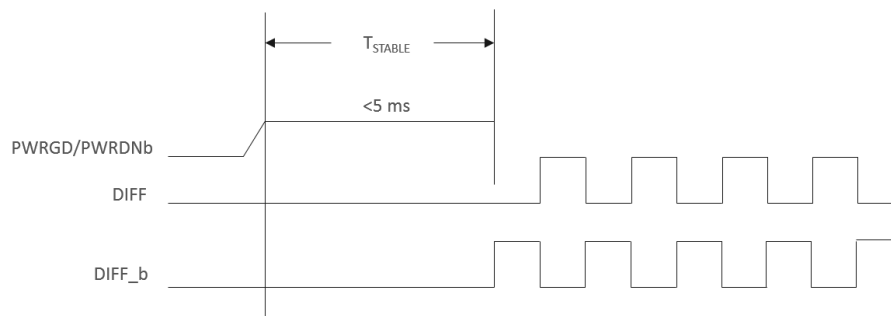

Figure 12. Initial Sample High of PWRGD/PWRDNb After Power Up

5.6. PWRDNb (Power Down) Assertion

The PWRDNb pin is an asynchronous active low input used to disable all output clocks in a glitch-free manner. In power down mode, all outputs, the crystal oscillator, and the I²C logic are disabled. In cases where the REF PWRDN (Byte 2, bit 2) is set to 1, the crystal oscillator and REF output will still be enabled. All disabled outputs will be driven low.

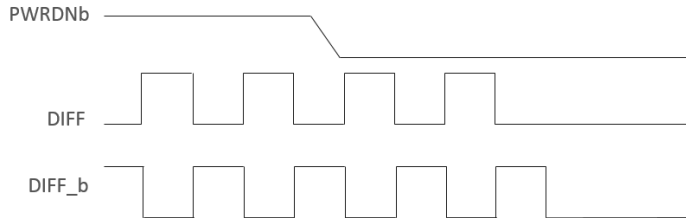

Figure 13. PWRDNb Assertion

5.7. PWRDNb (Power Down) Deassertion

When a valid rising edge on PWRGD/PWRDNb pin is applied, all outputs are enabled in a glitch-free manner within 520 μs.

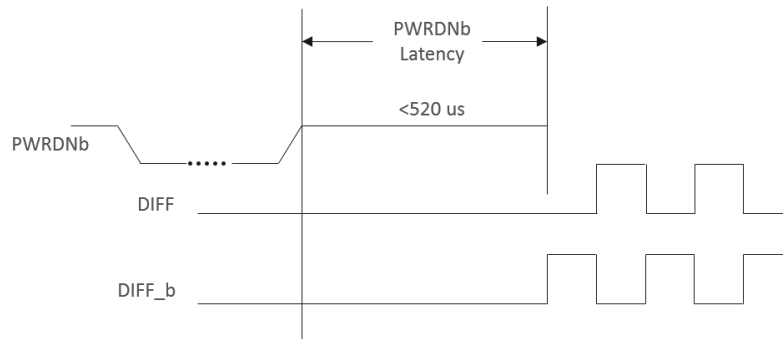

Figure 14. Subsequent Deassertion of PWRDNb

5.8. OEB Pin

The OEB pin is an active low input used to enable and disable the output clock. To enable the output clock, the OEB pin needs to be logic low, and I²C OE bit needs to be logic high. By default, the OEB pin is set to logic low, and I²C OE bit is set to logic high. There are two methods to disable the output clock: the OEB pin is pulled to a logic high, or the I²C OE bit is set to a logic low. This pin has a 100 kΩ internal pull-down.

5.9. OEB Assertion

The OEB pin is an active low input used for synchronous stopping and starting the respective output clock while the rest of the clock generator continues to function. The assertion of the OEB function is achieved by pulling the OEB pin low while the I²C OE bit is high, which causes the respective stopped output to resume normal operation. No short or stretched clock pulses are produced when the clocks resume.

5.10. OEB Deassertion

The OEB function is deasserted by pulling high or writing the I²C OE bit to a logic low. The corresponding output is stopped cleanly and the final output state is driven low.

5.11. FS Pin

The FS pin will select 0 = 100 MHz, mid = 200 MHz, and 1 = 133 MHz. This is a tri-state pin, which has a weak internal pull-down of approximately 100 kΩ.

The default output frequency is 100 MHz.

5.12. SS_EN Pin

The SS_EN pin will select 0 = -0.25% spread, mid = Spread is off, and 1 = -0.5% spread. This is a tri-state pin, which has a weak internal pull-up of approximately 100 kΩ.

The default is -0.5% spread.

5.13. Recommendations for Driving Tri-State Pins

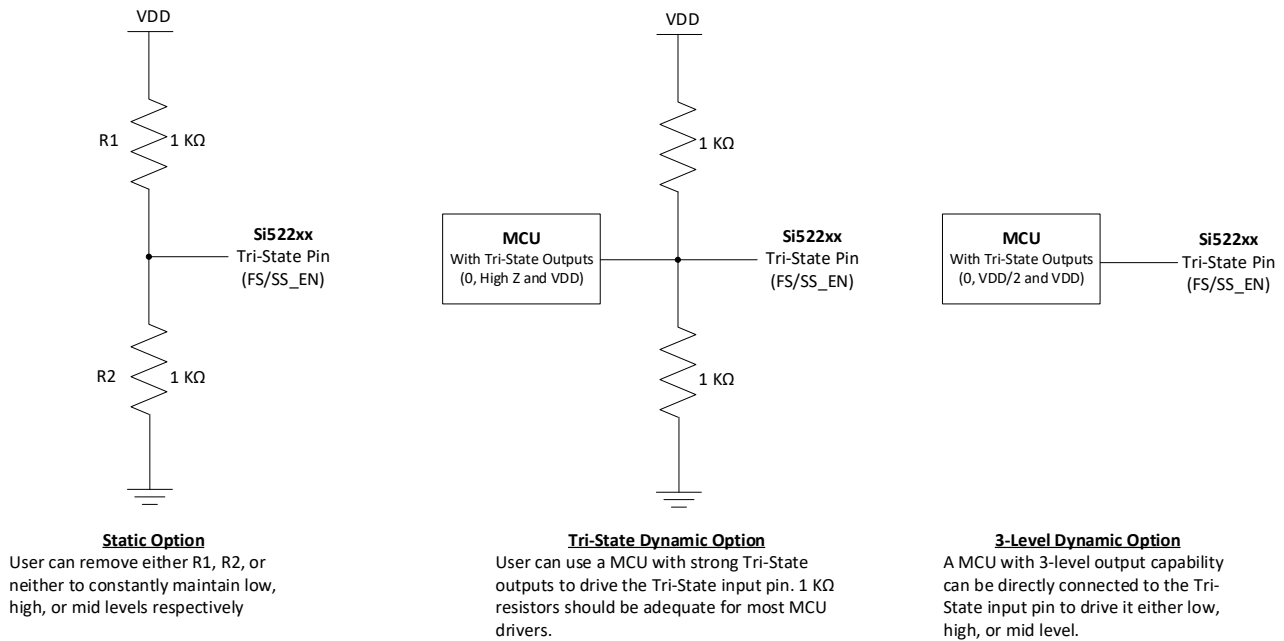

Figure 15. Tri-State Pin Schematics

5.14. REF/SA Pin

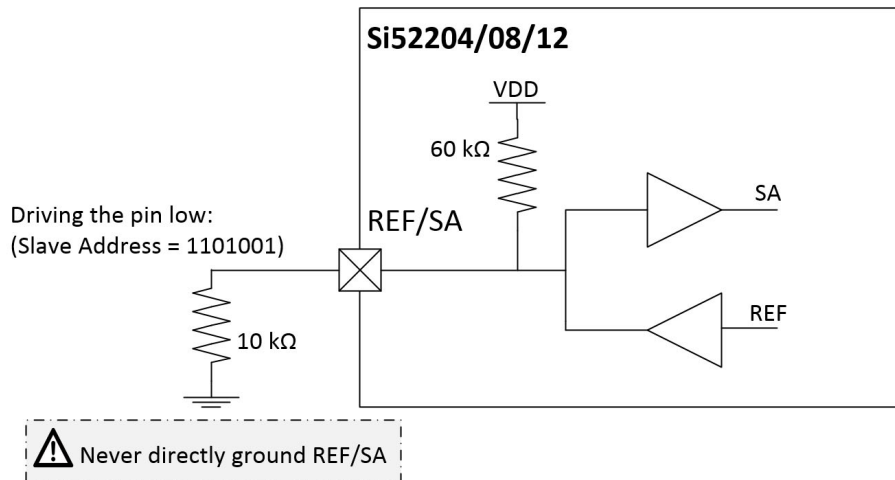

Figure 16. REF/SA Pin Function

The REF/SA pin is a dual-function input/output pin.

The SA functionality sets the Slave Address of the part. This address is latched to the value of the pin when the part initially powers up. See [Table 12, “SA State on First Application of PWRDNb,” on page 34](#) for the available addresses. By default, the internal 60 kΩ pull-up resistor will set SA to a value of 1. To drive the pin low, use a 10 kΩ pull-down resistor.

After the I²C address is latched on first power up, the REF/SA pin assumes its REF functionality. In REF mode, it will output a 25 MHz LVCMOS signal.

6. Test and Measurement Setup

The following diagrams show the test load configuration for the differential clock signals.

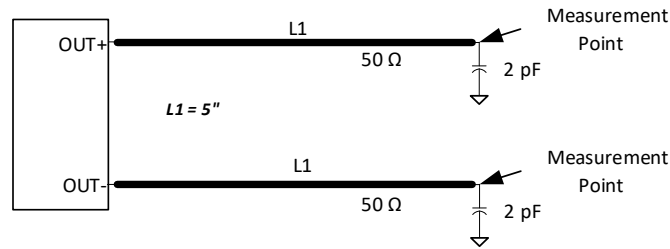

Figure 17. 0.7 V Differential Load Configuration

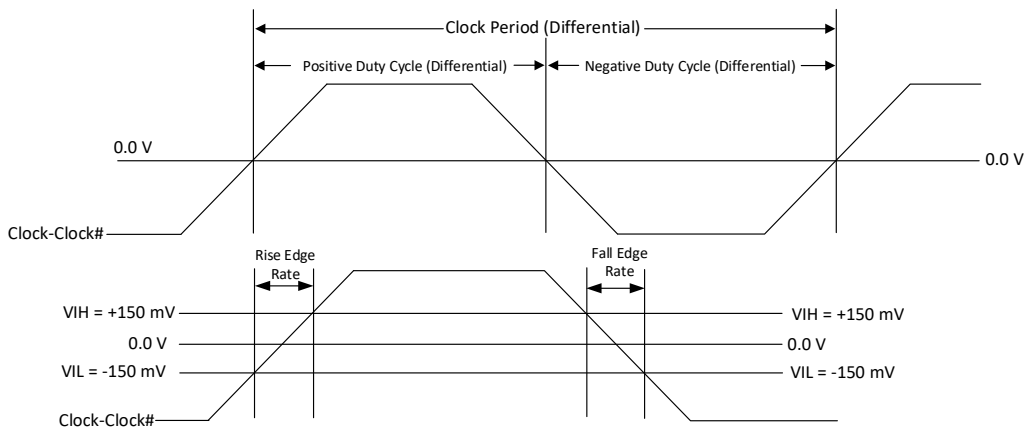

Figure 18. Differential Output Signals (for AC Parameters Measurement)

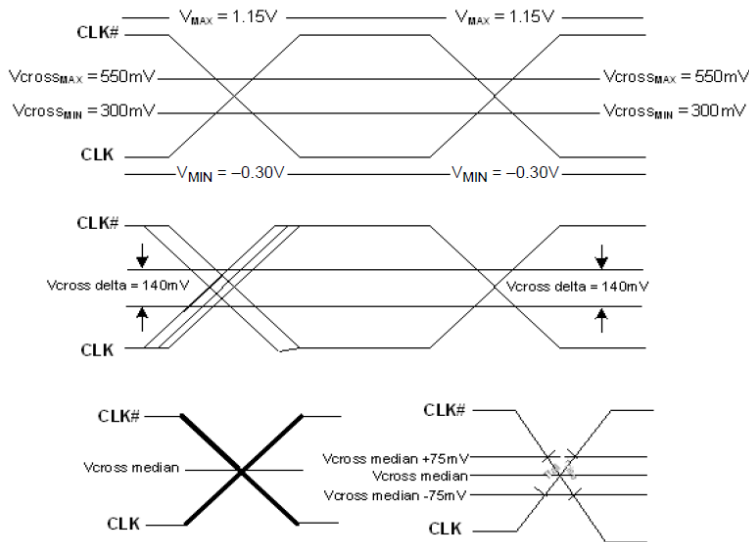

Figure 19. Single-Ended Measurement for Differential Output Signals (for AC Parameters Measurement)

7. PCIe Clock Jitter Tool

The PCIe Clock Jitter Tool is designed to enable users to quickly and easily take jitter measurements for PCIe Gen1/2/3/4/5 and SRNS/SRIS. This software removes all the guesswork for PCIe Gen1/2/3/4/5 and SRNS/SRIS jitter measurements and margins in board designs. This software tool will provide accurate results in just a few clicks, and is provided in an executable format to support various common input waveform files, such as .csv, .wfm, and .bin. The easy-to-use GUI and helpful tips guide users through each step. Release notes and other documentation are also included in the software package.

Download it for free at [Timing - PCI Express Learning Center](#).

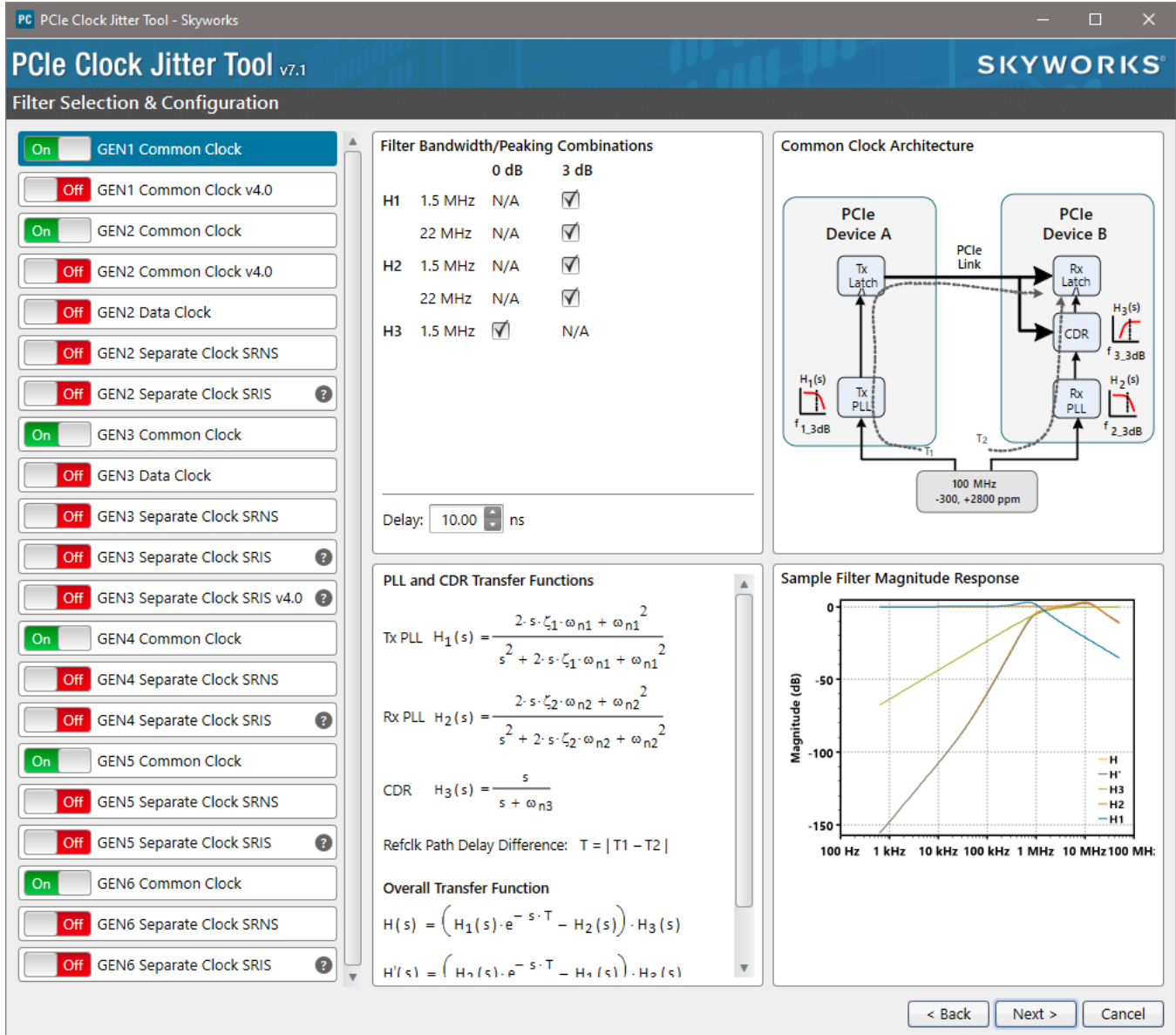

Figure 20. PCIe Clock Jitter Tool

8. Control Registers

8.1. I²C Interface

To enhance the flexibility and function of the clock synthesizer, an I²C interface is provided. Through the I²C interface, various device functions, such as individual clock output buffers, are individually enabled or disabled. The registers associated with the I²C interface initialize to their default setting at power-up. The use of this interface is optional. Clock device register changes are normally made at system initialization, if any are required.

8.2. Block Read/Write

The clock driver I²C protocol accepts block write and block read operations from the controller. For block write/read operation, access the bytes in sequential order from lowest to highest (most significant bit first) with the ability to stop after any complete byte is transferred. The block read and block write protocols are outlined in Table 13, “Block Read and Block Write Protocol,” on page 34.

8.3. Block Read

After the slave address is sent with the R/W condition bit set, the command byte is sent with the MSB = 0. The slave acknowledges the register index in the command byte. The master sends a repeat start function. After the slave acknowledges this, the slave sends the number of bytes it wants to transfer (>0 and ≤7). The master acknowledges each byte except the last and sends a stop condition.

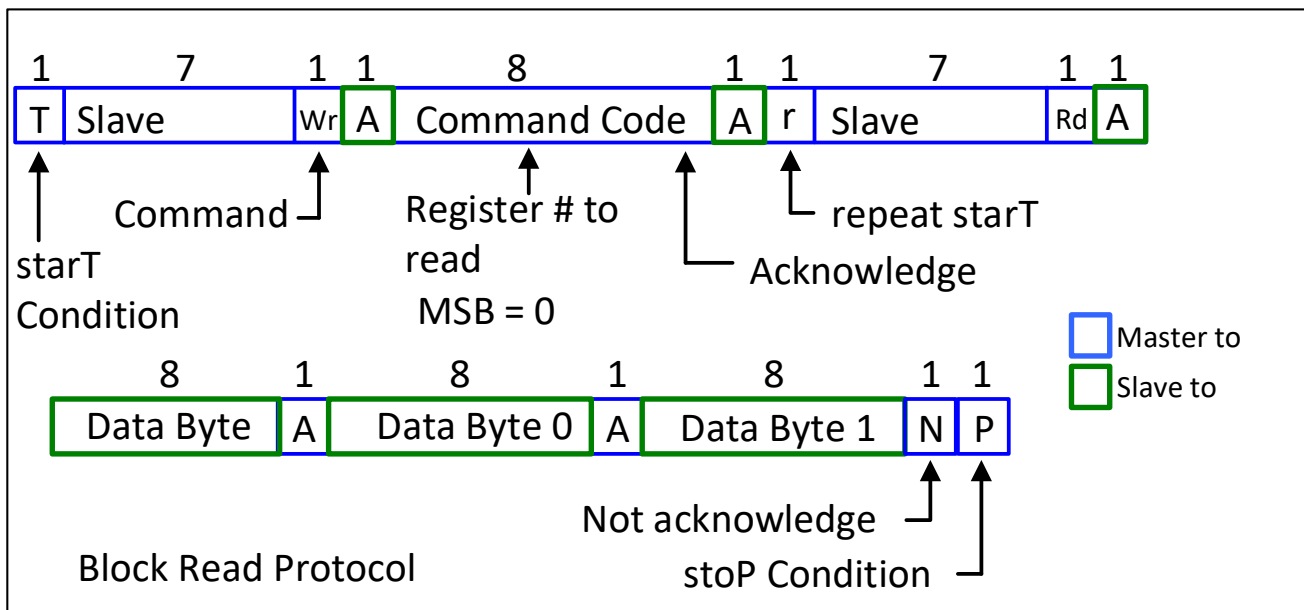

Figure 21. Block Read Protocol

8.4. Block Write

After the slave address is sent with the R/W condition bit not set, the command byte is sent with the MSB = 0. The lower seven bits indicate the register at which to start the transfer. If the command byte is 00h, the slave device will be compatible with existing block mode slave devices. The next byte of a block write must be the count of bytes that the master will transfer to the slave device. The byte count must be greater than zero and less than 7. Following this byte are the data bytes to be transferred to the slave device. The slave device always acknowledges each byte received. The transfer is terminated after the slave sends the Ack and the master sends a stop function.

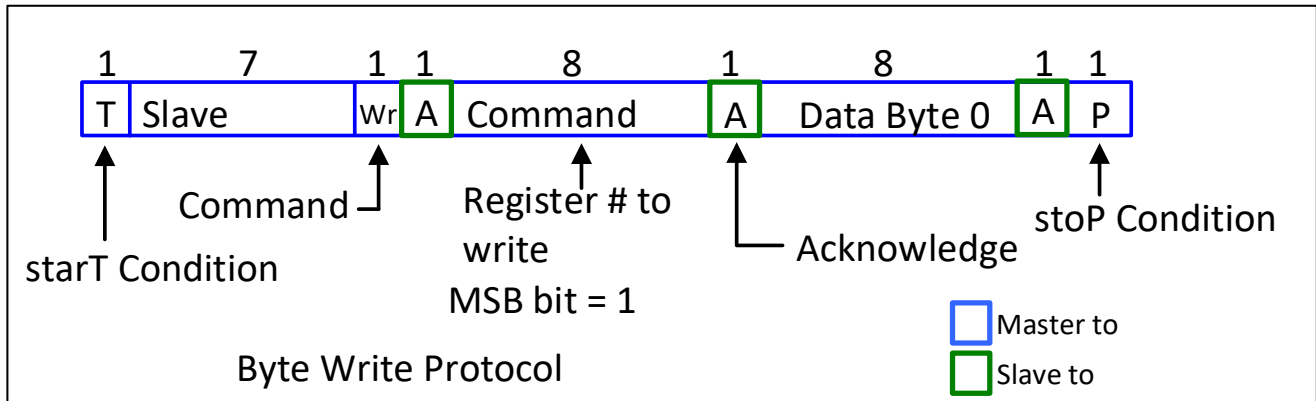

Figure 22. Block Write Protocol

8.5. Byte Read/Write

Reading or writing a register in an I²C slave device in byte mode always involves specifying the register number. Refer to Table 14, “Byte Read and Byte Write Protocol,” on page 35 for byte read and byte write protocol.

8.6. Byte Read

The standard byte read is as shown in the figure below. It is an extension of the byte write. The write start condition is repeated; then, the slave device starts sending data, and the master acknowledges it until the last byte is sent. The master terminates the transfer with a Nack, then a stop condition. For byte operation, the MSB bit of the command byte must be set. For block operations, the MSB bit must be set low. If the bit is not set low, the next byte must be the byte transfer count.

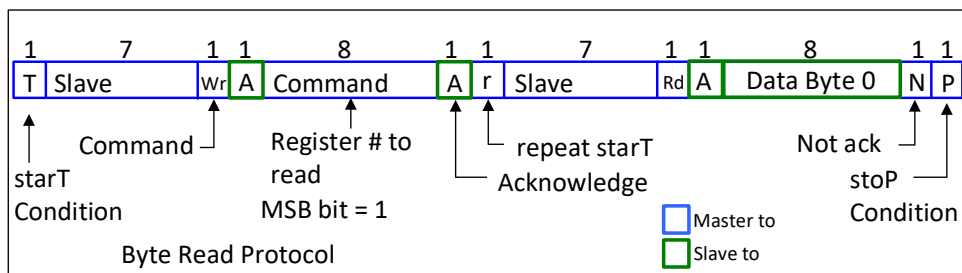

Figure 23. Byte Read Protocol

8.7. Byte Write

The figure below illustrates a simple, typical byte write. For byte operation, the MSB bit of the command byte must be set high. For block operations, the MSB bit must be set. If the bit is not set, the next byte must be the byte transfer count. The count can be between 1 and 32. It is not allowed to be zero or to exceed 32.

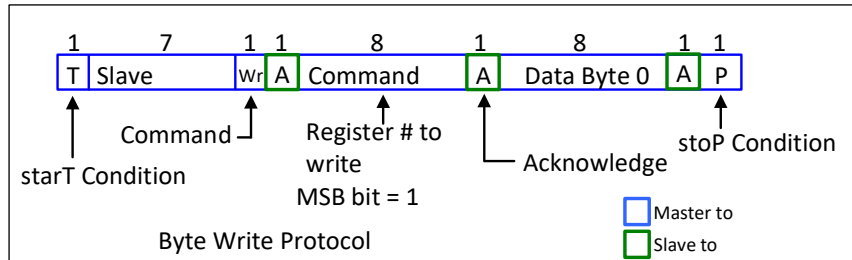

Figure 24. Byte Write Protocol

8.8. Data Protocol

The clock driver I²C protocol accepts byte write, byte read, block write, and block read operations from the controller. For block write/read operations, the system controller can access the bytes in sequential order from lowest to highest (most significant bit first) with the ability to stop after any complete byte is transferred. For byte write and byte read operations, the system controller can access individually indexed bytes. The block write and block read protocol is outlined in Table 13. "Block Read and Block Write Protocol" while Table 14, "Byte Read and Byte Write Protocol," on page 35 outlines byte write and byte read protocol. SA is the address select for I²C. When the part is powered up, SA will be latched to select the I²C address.

Table 12. SA State on First Application of PWRDNb

Description	SA	Address
State of SA on first deassertion of PWRDNb	0	1101001
	1	1101010

Table 13. Block Read and Block Write Protocol

Block Write Protocol		Block Read Protocol	
Bit	Description	Bit	Description
1	Start	1	Start
8:2	Slave address—7 bits	8:2	Slave address—7 bits
9	Write	9	Write
10	Acknowledge from slave	10	Acknowledge from slave
18:11	Command Code—8 bits	18:11	Command Code—8 bits
19	Acknowledge from slave	19	Acknowledge from slave

Table 13. Block Read and Block Write Protocol (Continued)

Block Write Protocol		Block Read Protocol	
Bit	Description	Bit	Description
27:20	Byte count—8 bits	20	Repeat start
28	Acknowledge from slave	27:21	Slave address—7 bits
36:29	Data byte 1—8 bits	28	Read = 1
37	Acknowledge from slave	29	Acknowledge from slave
45:38	Data byte 2—8 bits	37:30	Byte Count from slave—8 bits
46	Acknowledge from slave	38	Acknowledge
....	Data Byte/Slave Acknowledges	46:39	Data byte 1 from slave—8 bits
....	Data Byte N—8 bits	47	Acknowledge
....	Acknowledge from slave	55:48	Data byte 2 from slave—8 bits
....	Stop	56	Acknowledge
		Data bytes from slave/Acknowledge
		Data Byte N from slave—8 bits
		NOT Acknowledge
		Stop

Table 14. Byte Read and Byte Write Protocol

Byte Write Protocol		Byte Read Protocol	
Bit	Description	Bit	Description
1	Start	1	Start
8:2	Slave address—7 bits	8:2	Slave address—7 bits
9	Write	9	Write
10	Acknowledge from slave	10	Acknowledge from slave
18:11	Command Code—8 bits	18:11	Command Code—8 bits
19	Acknowledge from slave	19	Acknowledge from slave
27:20	Data byte—8 bits	20	Repeated start
28	Acknowledge from slave	27:21	Slave address—7 bits
29	Stop	28	Read
		29	Acknowledge from slave
		37:30	Data from slave—8 bits
		38	NOT Acknowledge
		39	Stop

8.9. Register Tables

8.9.1. Si52212 Registers

Table 15. Si52212 Control Register 0. Byte 0

Bit	Name	If Bit = 0	If Bit = 1	Type	Default	Function
7	DIFF7_OE	Disabled	Enabled	RW	1	Output enable for DIFF[7]
6	DIFF6_OE	Disabled	Enabled	RW	1	Output enable for DIFF[6]
5	DIFF5_OE	Disabled	Enabled	RW	1	Output enable for DIFF[5]
4	DIFF4_OE	Disabled	Enabled	RW	1	Output enable for DIFF[4]
3	DIFF3_OE	Disabled	Enabled	RW	1	Output enable for DIFF[3]
2	DIFF2_OE	Disabled	Enabled	RW	1	Output enable for DIFF[2]
1	DIFF1_OE	Disabled	Enabled	RW	1	Output enable for DIFF[1]
0	DIFF0_OE	Disabled	Enabled	RW	1	Output enable for DIFF[0]

Table 16. Si52212 Control Register 1. Byte 1

Bit	Name	If Bit = 0	If Bit = 1	Type	Default	Function
7	DIFF11_OE	Disabled	Enabled	RW	1	Output enable for DIFF[11]
6	DIFF10_OE	Disabled	Enabled	RW	1	Output enable for DIFF[10]
5	DIFF9_OE	Disabled	Enabled	RW	1	Output enable for DIFF[9]
4	DIFF8_OE	Disabled	Enabled	RW	1	Output enable for DIFF[8]
3	Reserved				0	Reserved
2					0	
1	SS_EN_READ1			R	0	Spread Enable software readback 00 = -0.25%; 01 = OFF; 10 = OFF; 11 = -0.5% The value of SS_EN_READ is latched on power-up.
0	SS_EN_READ0			R	0	

Table 17. Si52212 Control Register 2. Byte 2

Bit	Name	If Bit = 0	If Bit = 1	Type	Default	Function
7	SS_EN_SW_HW_CTRL	Read back Byte 1[1:0]	SS control by Byte 2 [6:5]	RW	0	Enable software control of spread
6	SS_EN_SW1			RW	0	Software control of spread 00 = -0.25%; 01 = OFF; 10 = OFF; 11 = -0.5%
5	SS_EN_SW0			RW	1	
4	Reserved				0	Reserved
3	REF_OE	Disabled	Enabled	RW	1	Output Enable for REF
2	REF_PWRDN	REF output is disabled in Power Down.	REF output is enabled in Power Down	RW	0	Wake-on LAN for REF. To have REF output enabled in Power Down, REF_OE needs to be enabled at the same time.
1	REF_SLR			RW	0	REF Output Slew Rate Control 00 = Slowest; 01 = Slow; 10 = Fast; 11 = Fastest
0				RW	1	

Table 18. Si52212 Control Register 3. Byte 3

Bit	Name	If Bit = 0	If Bit = 1	Type	Default	Function
7	SR_SEL_DIFF7	Slow setting	Fast setting	RW	1	Slew rate control for DIFF7
6	SR_SEL_DIFF6	Slow setting	Fast setting	RW	1	Slew rate control for DIFF6
5	SR_SEL_DIFF5	Slow setting	Fast setting	RW	1	Slew rate control for DIFF5
4	SR_SEL_DIFF4	Slow setting	Fast setting	RW	1	Slew rate control for DIFF4
3	SR_SEL_DIFF3	Slow setting	Fast setting	RW	1	Slew rate control for DIFF3
2	SR_SEL_DIFF2	Slow setting	Fast setting	RW	1	Slew rate control for DIFF2
1	SR_SEL_DIFF1	Slow setting	Fast setting	RW	1	Slew rate control for DIFF1
0	SR_SEL_DIFF0	Slow setting	Fast setting	RW	1	Slew rate control for DIFF0

Table 19. Si52212 Control Register 4. Byte 4

Bit	Name	If Bit = 0	If Bit = 1	Type	Default	Function
7	SR_SEL_DIFF11	Slow setting	Fast setting	RW	1	Slew rate control for DIFF11
6	SR_SEL_DIFF10	Slow setting	Fast setting	RW	1	Slew rate control for DIFF10
5	SR_SEL_DIFF9	Slow setting	Fast setting	RW	1	Slew rate control for DIFF9
4	SR_SEL_DIFF8	Slow setting	Fast setting	RW	1	Slew rate control for DIFF8
3	AMP			RW	1	DIFF Differential Outputs Amplitude Adjustment. 0110 : 600 mV 0111 : 650 mV 1000 : 700 mV 1001 : 750 mV 1010 : 800 mV 1011 : 850 mV
2	AMP			RW	0	
1	AMP			RW	0	
0	AMP			RW	0	

Table 20. Si52212 Control Register 5. Byte 5

Bit	Name	If Bit = 0	If Bit = 1	Type	Default	Function
7	Rev Code [7:4]			R	0	Revision Code
6				R	0	
5				R	0	
4				R	0	
3	Vendor ID[3:0]			R	1	Vendor Identification Code
2				R	0	
1				R	0	
0				R	0	

Table 21. Si52212 Control Register 6. Byte 6

Bit	Name	If Bit = 0	If Bit = 1	Type	Default	Function
7	Programming ID [7:0]			R	0	Programming ID (Internal Only)
6				R	0	
5				R	0	
4				R	0	
3				R	0	
2				R	0	
1				R	0	
0				R	0	

8.9.2. Si52208 Registers

Table 22. Si52208 Control Register 0. Byte 0

Bit	Name	If Bit = 0	If Bit = 1	Type	Default	Function
7	Reserved				0	Reserved
6	DIFF4_OE	Disabled	Enabled	RW	1	Output enable for DIFF_4
5	DIFF3_OE	Disabled	Enabled	RW	1	Output enable for DIFF_3
4	Reserved				0	Reserved
3	Reserved				0	Reserved
2	DIFF2_OE	Disabled	Enabled	RW	1	Output enable for DIFF_2
1	DIFF1_OE	Disabled	Enabled	RW	1	Output enable for DIFF_1
0	DIFF0_OE	Disabled	Enabled	RW	1	Output enable for DIFF_0

Table 23. Si52208 Control Register 1. Byte 1

Bit	Name	If Bit = 0	If Bit = 1	Type	Default	Function
7	DIFF7_OE	Disabled	Enabled	RW	1	Output enable for DIFF_7
6	DIFF6_OE	Disabled	Enabled	RW	1	Output enable for DIFF_6
5	Reserved				0	Reserved
4	DIFF5_OE	Disabled	Enabled	RW	1	Output enable for DIFF_5
3	Reserved				0	Reserved
2					0	
1	SS_EN_READ1			R	0	Spread Enable software readback 00 = -0.25%; 01 = OFF; 10 = OFF; 11 = -0.5% The value of SS_EN_READ is latched on power-up.
0	SS_EN_READ0			R	0	

Table 24. Si52208 Control Register 2. Byte 2

Bit	Name	If Bit = 0	If Bit = 1	Type	Default	Function
7	SS_EN_SW_HW_CTRL	Read back Byte 1[1:0]	SS control by Byte 2 [6:5]	RW	0	Enable software control of spread
6	SS_EN_SW1			RW	0	Software control of spread 00 = -0.25%; 01 = OFF; 10 = OFF; 11 = -0.5%
5	SS_EN_SW0			RW	1	
4	Reserved				0	Reserved
3	REF_OE	Disabled	Enabled	RW	1	Output Enable for REF
2	REF PWRDN	REF output is disabled in Power Down.	REF output is enabled in Power Down	RW	0	Wake-on LAN for REF. To have REF output enabled in Power Down, REF_OE needs to be enabled at the same time.

Table 24. Si52208 Control Register 2. Byte 2 (Continued)

Bit	Name	If Bit = 0	If Bit = 1	Type	Default	Function
1	REF_SLR			RW	0	REF Output Slew Rate Control 00 = Slowest; 01 = Slow; 10 = Fast; 11 = Fastest
0				RW	1	

Table 25. Si52208 Control Register 3. Byte 3

Bit	Name	If Bit = 0	If Bit = 1	Type	Default	Function
7	Reserved			RW	1	Reserved
6	SR_SEL_DIFF_4	Slow setting	Fast setting	RW	1	Slew rate control for DIFF_4
5	SR_SEL_DIFF_3	Slow setting	Fast setting	RW	1	Slew rate control for DIFF_3
4	Reserved			RW	1	Reserved
3	Reserved			RW	1	Reserved
2	SR_SEL_DIFF_2	Slow setting	Fast setting	RW	1	Slew rate control for DIFF_2
1	SR_SEL_DIFF_1	Slow setting	Fast setting	RW	1	Slew rate control for DIFF_1
0	SR_SEL_DIFF_0	Slow setting	Fast setting	RW	1	Slew rate control for DIFF_0

Table 26. Si52208 Control Register 4. Byte 4

Bit	Name	If Bit = 0	If Bit = 1	Type	Default	Function
7	SR_SEL_DIFF_7	Slow setting	Fast setting	RW	1	Slew rate control for DIFF_7
6	SR_SEL_DIFF_6	Slow setting	Fast setting	RW	1	Slew rate control for DIFF_6
5	Reserved			RW	1	Reserved
4	SR_SEL_DIFF_5	Slow setting	Fast setting	RW	1	Slew rate control for DIFF_5
3	AMP			RW	1	DIFF Differential Outputs Amplitude Adjustment. 0110 : 600 mV 0111 : 650 mV 1000 : 700 mV 1001 : 750 mV 1010 : 800 mV 1011 : 850 mV
2	AMP			RW	0	
1	AMP			RW	0	
0	AMP			RW	0	

Table 27. Si52208 Control Register 5. Byte 5

Bit	Name	If Bit = 0	If Bit = 1	Type	Default	Function
7	Rev Code [7:4]			R	0	Revision Code
6				R	0	
5				R	0	
4				R	0	
3	Vendor ID[3:0]			R	1	Vendor Identification Code
2				R	0	
1				R	0	
0				R	0	

Table 28. Si52208 Control Register 6. Byte 6

Bit	Name	If Bit = 0	If Bit = 1	Type	Default	Function
7	Programming ID [7:0]			R	0	Programming ID (Internal Only)
6				R	0	
5				R	0	
4				R	0	
3				R	0	
2				R	0	
1				R	0	
0				R	0	

8.9.3. Si52204 Registers

Table 29. Si52204 Control Register 0. Byte 0

Bit	Name	If Bit = 0	If Bit = 1	Type	Default	Function
7	Reserved				0	Reserved
6	DIFF2_OE	Disabled	Enabled	RW	1	Output enable for DIFF_2
5	DIFF1_OE	Disabled	Enabled	RW	1	Output enable for DIFF_1
4	Reserved				0	Reserved
3	Reserved				0	Reserved
2	DIFF0_OE	Disabled	Enabled	RW	1	Output enable for DIFF_0
1	Reserved			RW	0	Reserved
0	Reserved			RW	0	Reserved

Table 30. Si52204 Control Register 1. Byte 1

Bit	Name	If Bit = 0	If Bit = 1	Type	Default	Function
7	Reserved				0	Reserved
6	Reserved				0	Reserved
5	Reserved				0	Reserved
4	DIFF3_OE	Disabled	Enabled	RW	1	Output enable for DIFF_3
3	Reserved				0	Reserved
2					0	
1	SS_EN_READ1			R	0	Spread Enable software readback 00 = -0.25%; 01 = OFF; 10 = OFF; 11 = -0.5% The value of SS_EN_READ is latched on power-up.
0	SS_EN_READ0			R	0	

Table 31. Si52204 Control Register 2. Byte 2

Bit	Name	If Bit = 0	If Bit = 1	Type	Default	Function
7	SS_EN_SW_HW_CTRL	Read back Byte 1[1:0]	SS control by Byte 2 [6:5]	RW	0	Enable software control of spread
6	SS_EN_SW1			RW	0	Software control of spread 00 = -0.25%; 01 = OFF; 10 = OFF; 11 = -0.5%
5	SS_EN_SW0			RW	1	
4	Reserved				0	Reserved
3	REF_OE	Disabled	Enabled	RW	1	Output Enable for REF
2	REF_PWRDN	REF output is disabled in Power Down.	REF output is enabled in Power Down	RW	0	Wake-on LAN for REF. To have REF output enabled in Power Down, REF_OE needs to be enabled at the same time.

Table 31. Si52204 Control Register 2. Byte 2 (Continued)

Bit	Name	If Bit = 0	If Bit = 1	Type	Default	Function
1	REF_SLR			RW	0	REF Output Slew Rate Control 00 = Slowest; 01 = Slow; 10 = Fast; 11 = Fastest
0				RW	1	

Table 32. Si52204 Control Register 3. Byte 3

Bit	Name	If Bit = 0	If Bit = 1	Type	Default	Function
7	Reserved			RW	1	Reserved
6	SR_SEL_DIFF_2	Slow setting	Fast setting	RW	1	Slew rate control for DIFF_2
5	SR_SEL_DIFF_1	Slow setting	Fast setting	RW	1	Slew rate control for DIFF_1
4	Reserved			RW	1	Reserved
3	Reserved			RW	1	Reserved
2	SR_SEL_DIFF_0	Slow setting	Fast setting	RW	1	Slew rate control for DIFF_0
1	Reserved			RW	1	Reserved
0	Reserved			RW	1	Reserved

Table 33. Si52204 Control Register 4. Byte 4

Bit	Name	If Bit = 0	If Bit = 1	Type	Default	Function
7	Reserved			RW	1	Reserved
6	Reserved			RW	1	Reserved
5	Reserved			RW	1	Reserved
4	SR_SEL_DIFF_3	Slow setting	Fast setting	RW	1	Slew rate control for DIFF_3
3	AMP			RW	1	DIFF Differential Outputs Amplitude Adjustment. 0110 : 600 mV 0111 : 650 mV 1000 : 700 mV 1001 : 750 mV 1010 : 800 mV 1011 : 850 mV
2	AMP			RW	0	
1	AMP			RW	0	
0	AMP			RW	0	

Table 34. Si52204 Control Register 5. Byte 5

Bit	Name	If Bit = 0	If Bit = 1	Type	Default	Function
7	Rev Code [7:4]			R	0	Revision Code
6				R	0	
5				R	0	
4				R	0	
3	Vendor ID[3:0]			R	1	Vendor Identification Code
2				R	0	
1				R	0	
0				R	0	

Table 35. Si52204 Control Register 6. Byte 6

Bit	Name	If Bit = 0	If Bit = 1	Type	Default	Function
7	Programming ID [7:0]			R	0	Programming ID (Internal Only)
6				R	0	
5				R	0	
4				R	0	
3				R	0	
2				R	0	
1				R	0	
0				R	0	

8.9.4. Si52202 Registers

Table 36. Si52202 Control Register 0. Byte 0

Bit	Name	If Bit = 0	If Bit = 1	Type	Default	Function
7	Reserved				0	Reserved
6	DIFF0_OE	Disabled	Enabled	RW	1	Output enable for DIFF_0
5	Reserved				0	Reserved
4	Reserved				0	Reserved
3	Reserved				0	Reserved
2	Reserved				0	Reserved
1	Reserved				0	Reserved
0	Reserved				0	Reserved

Table 37. Si52202 Control Register 1. Byte 1

Bit	Name	If Bit = 0	If Bit = 1	Type	Default	Function
7	Reserved				0	Reserved
6	Reserved				0	Reserved
5	DIFF1_OE	Disabled	Enabled	RW	1	Output enable for DIFF_1
4	Reserved				0	Reserved
3	Reserved				0	Reserved
2					0	
1	SS_EN_READ1			R	0	Spread Enable software readback 00 = -0.25%; 01 = OFF; 10 = OFF; 11 = -0.5% The value of SS_EN_READ is latched on power-up.
0	SS_EN_READ0			R	0	

Table 38. Si52202 Control Register 2. Byte 2

Bit	Name	If Bit = 0	If Bit = 1	Type	Default	Function
7	SS_EN_SW_HW_CTRL	Read back Byte 1[1:0]	SS control by Byte 2 [6:5]	RW	0	Enable software control of spread
6	SS_EN_SW1			RW	0	Software control of spread 00 = -0.25%; 01 = OFF; 10 = OFF; 11 = -0.5%
5	SS_EN_SW0			RW	1	
4	Reserved				0	Reserved
3	Reserved				0	Reserved
2	Reserved				0	Reserved
1	Reserved				0	Reserved

Table 38. Si52202 Control Register 2. Byte 2 (Continued)

Bit	Name	If Bit = 0	If Bit = 1	Type	Default	Function
0	Reserved				1	Reserved

Table 39. Si52202 Control Register 3. Byte 3

Bit	Name	If Bit = 0	If Bit = 1	Type	Default	Function
7	Reserved				1	Reserved
6	SR_SEL_DIFF_0	Slow setting	Fast setting	RW	1	Slew rate control for DIFF_2
5	Reserved				1	Reserved
4	Reserved				1	Reserved
3	Reserved				1	Reserved
2	Reserved				1	Reserved
1	Reserved				1	Reserved
0	Reserved				1	Reserved

Table 40. Si52202 Control Register 4. Byte 4

Bit	Name	If Bit = 0	If Bit = 1	Type	Default	Function
7	Reserved				1	Reserved
6	Reserved				1	Reserved
5	SR_SEL_DIFF_1	Slow setting	Fast setting	RW	1	Slew rate control for DIFF_1
4	Reserved				1	Reserved
3	AMP			RW	1	DIFF Differential Outputs Amplitude Adjustment. 0110 : 600 mV 0111 : 650 mV 1000 : 700 mV 1001 : 750 mV 1010 : 800 mV 1011 : 850 mV
2	AMP			RW	0	
1	AMP			RW	0	
	AMP			RW	0	
0	AMP			RW	0	

Table 41. Si52202 Control Register 5. Byte 5

Bit	Name	If Bit = 0	If Bit = 1	Type	Default	Function
7	Rev Code [7:4]			R	0	Revision Code
6				R	0	
5				R	0	
4				R	0	
3	Vendor ID[3:0]			R	1	Vendor Identification Code
2				R	0	
1				R	0	
0				R	0	

Table 42. Si52202 Control Register 6. Byte 6

Bit	Name	If Bit = 0	If Bit = 1	Type	Default	Function
7	Programming ID [7:0]			R	0	Programming ID (Internal Only)
6				R	0	
5				R	0	
4				R	0	
3				R	0	
2				R	0	
1				R	0	
0				R	0	

9. Packaging

9.1. Si52212 Package

The figure below illustrates the package details for the Si52212 in a 64-Lead 9 x 9 mm QFN package. The table lists the values for the dimensions shown in the illustration.

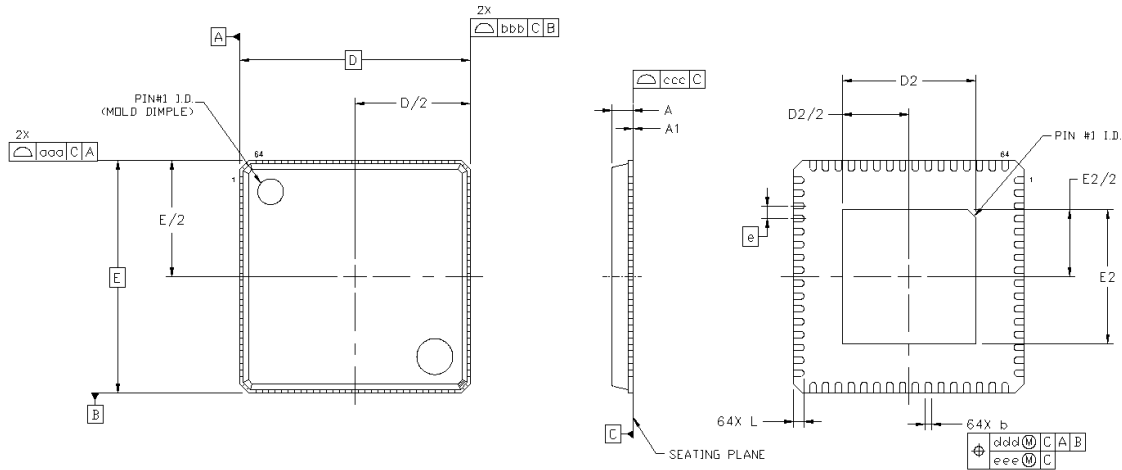

Figure 25. Si52212 Package Diagram

Table 43. Si52212 Package Dimensions

Dimension	Min	Nom	Max	Notes
A	0.80	0.85	0.90	All dimensions shown are in millimeters (mm) unless otherwise noted. Dimensioning and Tolerancing per ANSI Y14.5M-1994. This drawing conforms to JEDEC Outline MO-220. Recommended card reflow profile is per JEDEC/IPC J-STD-020D specification for Small Body Components.
A1	0.00	0.02	0.05	
b	0.18	0.25	0.30	
D	9.00 BSC			
D2	5.10	5.20	5.30	
e	0.50 BSC			
E	9.00 BSC			
E2	5.10	5.20	5.30	
L	0.30	0.40	0.50	
aaa	0.15			
bbb	0.10			
ccc	0.08			
ddd	0.10			
eee	0.05			

9.2. Si52212 Land Pattern

The following figure illustrates the land pattern details for the Si52212 in a 64-Lead 9 x 9 mm QFN package. The table lists the values for the dimensions shown in the illustration.

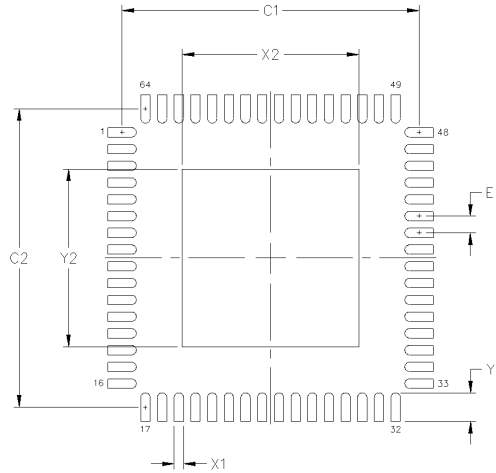

Figure 26. Si52212 Land Pattern

Table 44. Si52212 PCB Land Pattern Dimensions

Dimension	mm	Notes
C1	8.90	General 1. All dimensions shown are in millimeters (mm). 2. This land pattern design is based on the IPC-7351 guidelines. 3. All dimensions shown are at Maximum Material Condition (MMC). Least Material Condition (LMC) is calculated based on a fabrication allowance of 0.05 mm. Solder Mask Design 1. All metal pads are to be Non-Solder Mask Defined (NSMD). Clearance between the solder mask and the metal pad is to be 60 mm minimum, all the way around the pad. Stencil Design 1. A stainless steel, laser-cut and electro-polished stencil with trapezoidal walls should be used to assure good solder paste release. 2. The stencil thickness should be 0.125 mm (5 mils). 3. The ratio of stencil aperture to land pad size should be 1:1 for all pads. 4. A 3x3 array of 1.25 mm square openings on a 1.80 mm pitch should be used for the center ground pad. Card Assembly 1. A no-clean, Type-3 solder paste is recommended. 2. The recommended card reflow profile is per the JEDEC/IPC J-STD-020 specification for small body components.
C2	8.90	
E	0.50	
X1	0.30	
Y1	0.85	
X2	5.30	
Y2	5.30	

9.3. Si52212 Top Markings

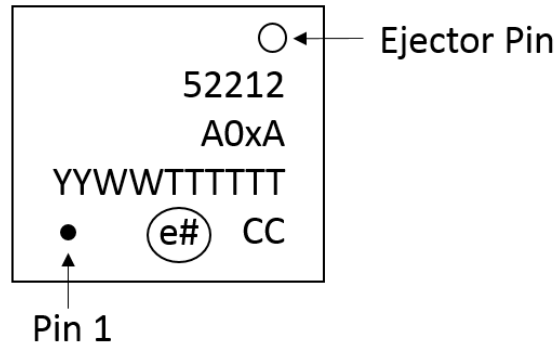

Figure 27. Si52212 Top Marking

Table 45. Si52212 Top Marking Explanation

Line	Characters	Description
1	52212	Device part number
2	A0xA	Device part number x = 1 = Internal 100 Ω impedance matching x = 2 = Internal 85 Ω impedance matching
3	YYWWTTTTTT	YY = Assembly year WW = Assembly work week TTTTTT = Manufacturing trace code
4	e# CC	e# = Lead finish symbol. # is a number CC = Country of origin (ISO abbreviation)

9.4. Si52208 Package

The figure below illustrates the package details for the Si52208 in a 48-Lead 6 x 6 mm QFN package. The table lists the values for the dimensions shown in the illustration.

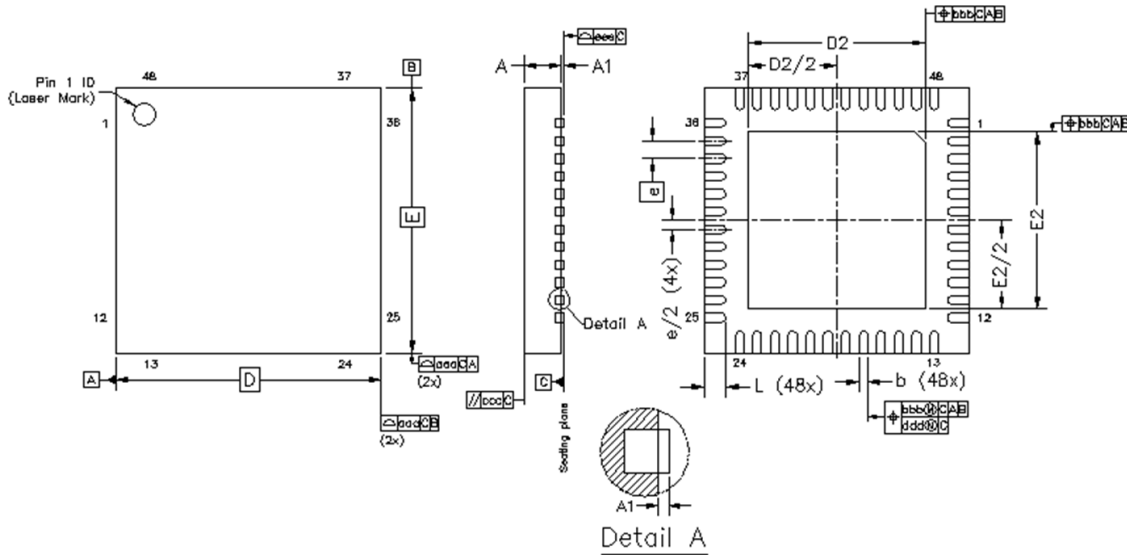

Figure 28. Si52208 Package Diagram

Table 46. Si52208 Package Dimensions

Dimension	Min	Nom	Max	Notes
A	0.80	0.85	0.90	All dimensions shown are in millimeters (mm) unless otherwise noted. Dimensioning and Tolerancing per ANSI Y14.5M-1994. This drawing conforms to JEDEC Outline MO-220. Recommended card reflow profile is per JEDEC/IPC J-STD-020 specification for Small Body Components.
A1	0.00	0.02	0.05	
b	0.15	0.20	0.25	
D	6.00 BSC			
D2	3.5	3.6	3.7	
e	0.40 BSC			
E	6.00 BSC			
E2	3.5	3.6	3.7	
L	0.30	0.40	0.50	
aaa	0.10			
bbb	0.10			
ccc	0.10			
ddd	0.05			
eee	0.08			

9.5. Si52208 Land Pattern

The figure below illustrates the land pattern details for the Si52208 in a 48-Lead, 6 x 6 mm QFN package. The table lists the values for the dimensions shown in the illustration.

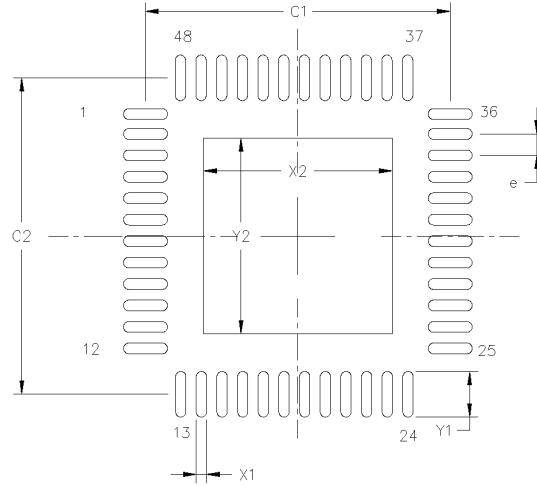

Figure 29. Si52208 Land Pattern

Table 47. Si52208 PCB Land Pattern Dimensions

Dimension	mm	Notes
C1	5.90	General 1. All dimensions shown are in millimeters (mm) unless otherwise noted. 2. Dimensioning and tolerancing is per the ANSI Y14.5M-1994 specification. 3. This land pattern design is based on IPC-7351 guidelines. 4. All dimensions shown are at Maximum Material Condition (MMC). Least Material Condition (LMC) is calculated based on a fabrication allowance of 0.05 mm. Solder Mask Design 1. All metal pads are to be Non-Solder Mask Defined (NSMD). Clearance between the solder mask and the metal pad is to be 60 μm minimum, all the way around the pad. Stencil Design 1. A stainless steel, laser-cut and electro-polished stencil with trapezoidal walls should be used to assure good solder paste release. 2. The stencil thickness should be 0.125 mm (5 mils). 3. The ratio of stencil aperture to land pad size should be 1:1 for the perimeter pads. 4. A 3x3 array of 0.90 mm square openings on 1.15 mm pitch should be used for the center ground pad. Card Assembly 1. A no-clean, Type-3 solder paste is recommended. 2. The recommended card reflow profile is per the JEDEC/IPC J-STD-020 specification for small body components.
C2	5.90	
X1	0.20	
X2	3.60	
Y1	0.85	
Y2	3.60	
e	0.40 BSC	

9.6. Si52208 Top Markings



Figure 30. Si52208 Top Marking

Table 48. Si52208 Top Marking Explanation

Line	Characters	Description
1	52208	Device part number
2	A0xA	Device part number x = 1 = Internal 100 Ω impedance matching x = 2 = Internal 85 Ω impedance matching
3	TTTTTT	TTTTTT = Manufacturing trace code
4	YYWW	YY = Assembly year WW = Assembly work week

9.7. Si52204 Package

The figure below illustrates the package details for the Si52204 in a 32-Lead, 5 x 5 mm QFN package. The table lists the values for the dimensions shown in the illustration.

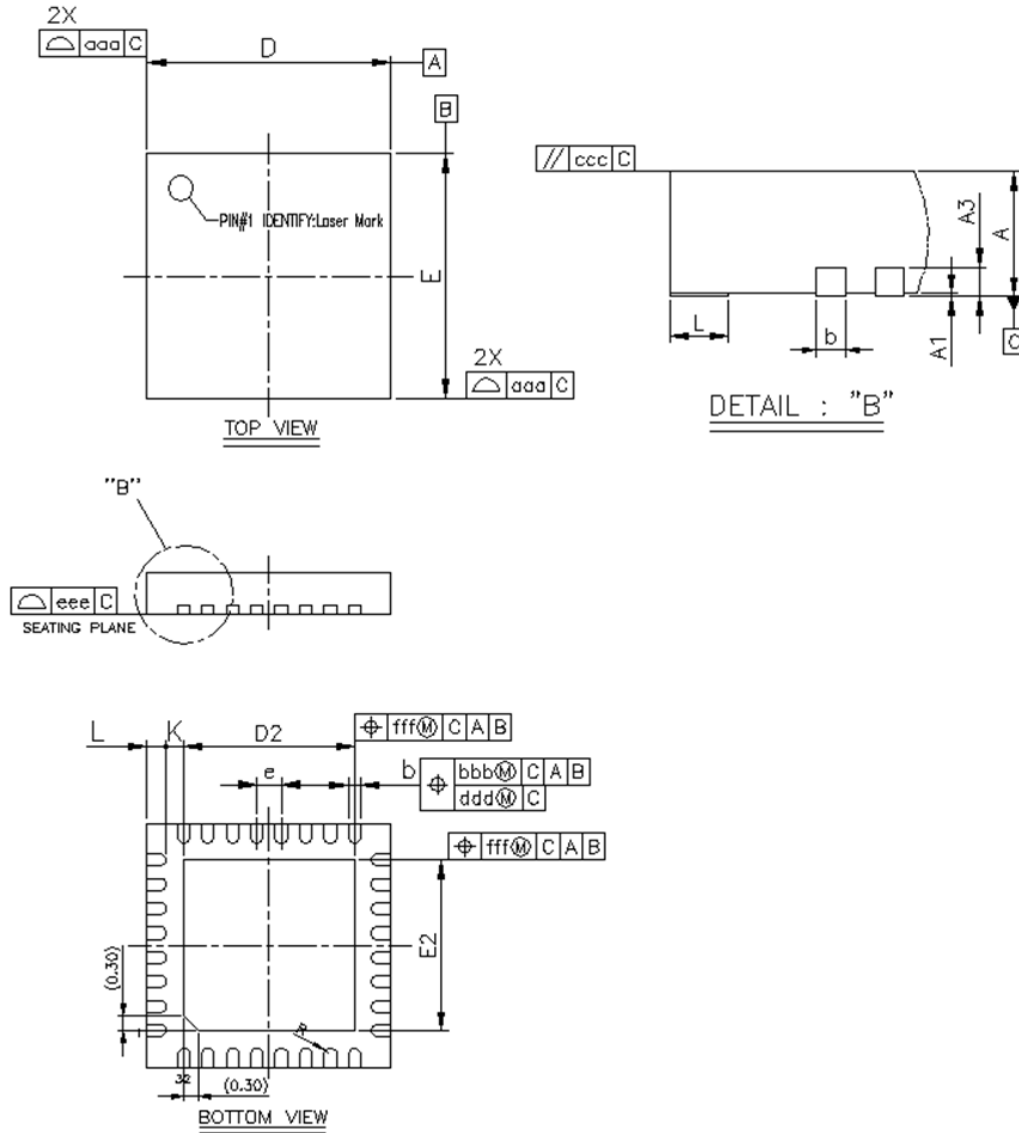

Figure 31. Si52204 Package Diagram

Table 49. Si52204 Package Dimensions

Dimension	Min	Nom	Max	Notes
A	0.80	0.85	0.90	All dimensions shown are in millimeters (mm) unless otherwise noted. Dimensioning and Tolerancing per ANSI Y14.5M-1994. This drawing conforms to the JEDEC Solid State Outline MO-220, Variation VKKD-4. Recommended card reflow profile is per JEDEC/IPC J-STD-020 specification for Small Body Components.
A1	0.00	0.02	0.05	
A3	0.20 REF			
b	0.18	0.25	0.30	
D/E	4.90	5.00	5.10	
D2/E2	3.40	3.50	3.60	
E	0.50 BSC			
K	0.20	—	—	
L	0.30	0.40	0.50	
R	0.09	—	0.14	
aaa	0.15			
bbb	0.10			
ccc	0.10			
ddd	0.05			
eee	0.08			
fff	0.10			

9.8. Si52204 Land Pattern

The figure below illustrates the land pattern details for the Si52204 in a 32-Lead, 5 x 5 mm QFN package. The table lists the values for the dimensions shown in the illustration.

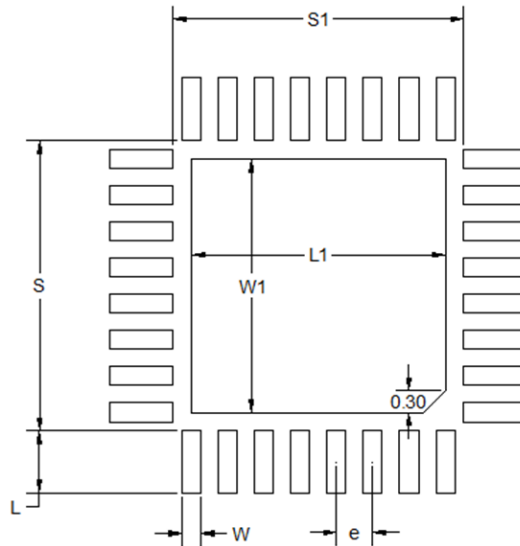

Figure 32. Si52204 Land Pattern

Table 50. Si52204 PCB Land Pattern Dimensions

Dimension	mm	Notes
S1	4.01	General 1. All dimensions shown are in millimeters (mm) unless otherwise noted. 2. This Land Pattern Design is based on IPC-7351 guidelines. Solder Mask Design 1. All metal pads are to be Non-Solder Mask Defined (NSMD). Clearance between the solder mask and the metal pad is to be 60 mm minimum, all the way around the pad. Stencil Design 1. A stainless steel, laser-cut and electro-polished stencil with trapezoidal walls should be used to assure good solder paste release. 2. The stencil thickness should be 0.125 mm (5 mils). 3. The ratio of stencil aperture to land pad size can be 1:1 for all perimeter pads. 4. A 3x3 array of 0.85 mm square openings on 1.00 mm pitch can be used for the center ground pad. Card Assembly 1. A No-Clean, Type-3 solder paste is recommended. 2. The recommended card reflow profile is per the JEDEC/IPC J-STD-020 specification for small body components.
S	4.01	
L1	3.50	
W1	3.50	
e	0.50	
W	0.26	
L	0.86	

9.9. Si52204 Top Markings

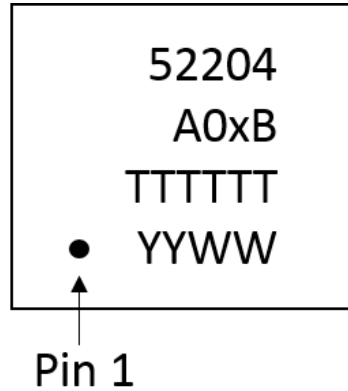

Figure 33. Si52204 Top Marking

Table 51. Si52204 Top Marking Explanation

Line	Characters	Description
1	52204	Device part number
2	A0xB	Device part number x = 1 = Internal 100 Ω impedance matching x = 2 = Internal 85 Ω impedance matching
3	TTTTTT	TTTTTT = Manufacturing trace code
4	YYWW	YY = Assembly year WW = Assembly work week

9.10. Si52202 Package

The figure below illustrates the package details for the Si52202 in a 20-Lead, 3 x 3 mm QFN package. The table lists the values for the dimensions shown in the illustration.

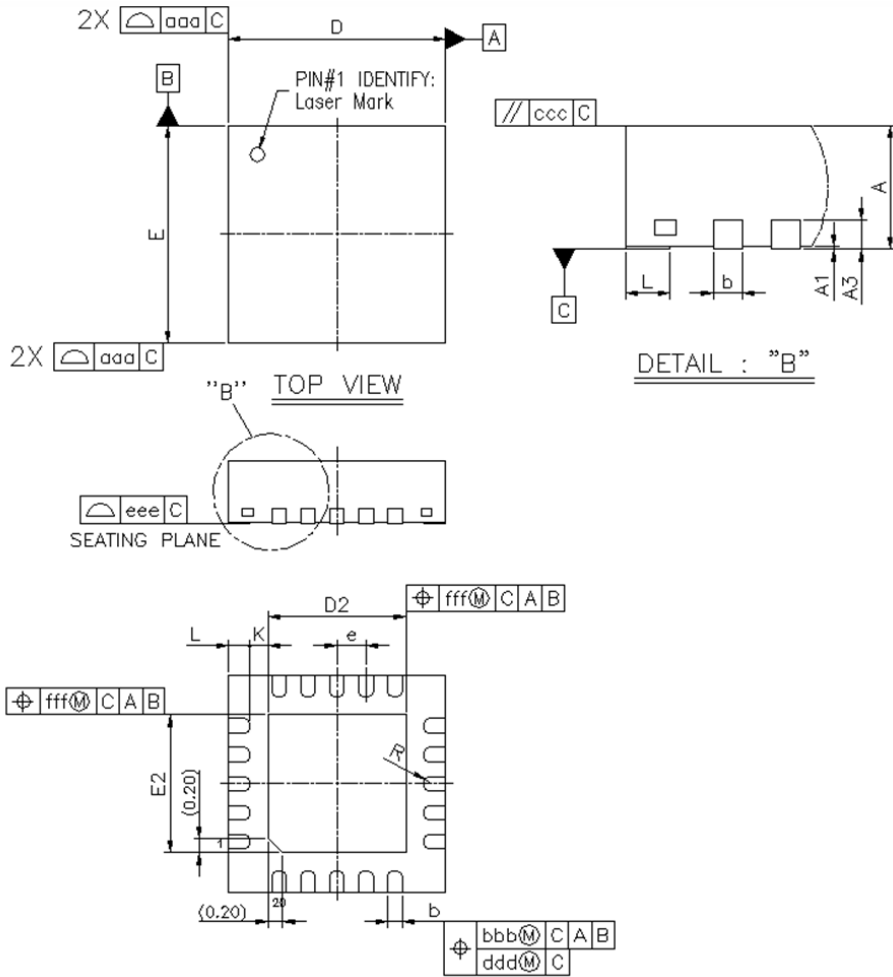

Figure 34. Si52202 Package Diagram

Table 52. Si52202 Package Dimensions

Dimension	Min	Nom	Max	Notes
A	0.80	0.85	0.90	All dimensions shown are in millimeters (mm) unless otherwise noted. Dimensioning and Tolerancing per ANSI Y14.5M-1994. The drawing complies with JEDEC MO-220. Recommended card reflow profile is per the JEDEC/IPC J-STD-020 specification for Small Body Components.
A1	0.00	0.02	0.05	
A3	—	0.65	—	
A3	0.20 REF			
b	0.15	0.20	0.25	
D	3.00 BSC			
D2	1.8	1.9	2.0	
E	3.00 BSC			
E2	1.8	1.9	2.0	
e	0.40 BSC			
K	0.20	—	—	
L	0.20	0.30	0.40	
R	0.075	—	0.125	
aaa	0.10			
bbb	0.07			
ccc	0.10			
ddd	0.05			
eee	0.08			
fff	0.10			

9.11. Si52202 Land Pattern

The figure below illustrates the land pattern details for the Si52202 in a 20-Lead, 3 x 3 mm QFN package. The table lists the values for the dimensions shown in the illustration.

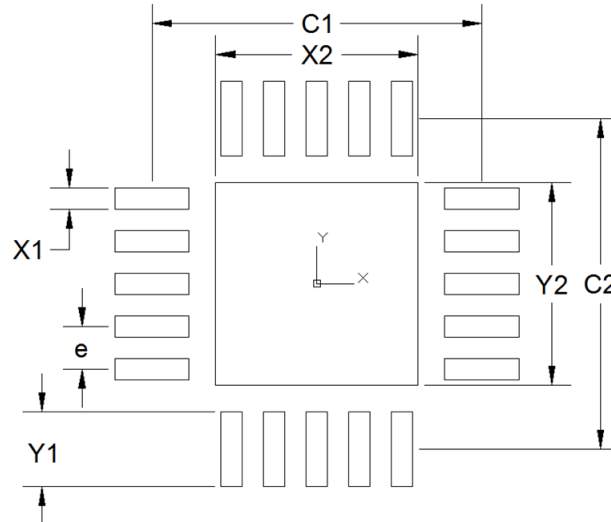

Figure 35. Si52202 Land Pattern

Table 53. Si52202 PCB Land Pattern Dimensions

Dimension	mm	Notes
C1	3.10	General 1. All dimensions shown are in millimeters (mm) unless otherwise noted. 2. Dimensioning and Tolerancing is per the ANSI Y14.5M-1994 specification. 3. This Land Pattern Design is based on IPC-7351 guidelines. 4. All dimensions shown are at Maximum Material Condition (MMC). Least Material Condition (LMC) is calculated based on a fabrication allowance of 0.05 mm.
C2	3.10	
X1	0.20	
X2	1.90	
Y1	0.70	Solder Mask Design 1. All metal pads are to be Non-Solder Mask Defined (NSMD). Clearance between the solder mask and the metal pad is to be 60 μm minimum, all the way around the pad.
Y2	1.90	
e	0.40 BSC	Stencil Design 1. A stainless steel, laser-cut and electro-polished stencil with trapezoidal walls should be used to assure good solder paste release. 2. The stencil thickness should be 0.125 mm (5 mils). 3. The ratio of stencil aperture to land pad size should be 1:1 for the perimeter pads. 4. A 3x3 array of 0.90 mm square openings on 1.15 mm pitch should be used for the center ground pad.
		Card Assembly 1. A No-Clean, Type-3 solder paste is recommended. 2. The recommended card reflow profile is per the JEDEC/IPC J-STD-020 specification for small body components.

9.12. Si52202 Top Markings

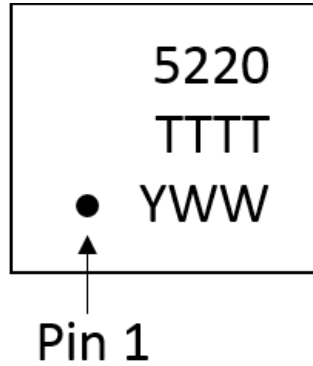

Figure 36. Si52202 Top Marking

Table 54. Si52202 Top Marking Explanation

Line	Characters	Description
1	5220	Device part number
2	TTTT	TTTT = Manufacturing trace code
3	YWW	Y = Assembly year WW = Assembly work week

10. Ordering Information

Table 55. Si522x Ordering Guide

Number of Outputs	Internal Termination	Part Number	Package Type	Temperature
12-output	100 Ω	Si52212-A01AGM	64-QFN	Extended, -40 to 85 °C
		Si52212-A01AGMR	64-QFN - Tape and Reel	Extended, -40 to 85 °C
	85 Ω	Si52212-A02AGM	64-QFN	Extended, -40 to 85 °C
		Si52212-A02AGMR	64-QFN - Tape and Reel	Extended, -40 to 85 °C
8-output	100 Ω	Si52208-A01AGM	48-QFN	Extended, -40 to 85 °C
		Si52208-A01AGMR	48-QFN - Tape and Reel	Extended, -40 to 85 °C
	85 Ω	Si52208-A02AGM	48-QFN	Extended, -40 to 85 °C
		Si52208-A02AGMR	48-QFN - Tape and Reel	Extended, -40 to 85 °C
4-output	100 Ω	Si52204-A01BGM	32-QFN	Extended, -40 to 85 °C
		Si52204-A01BGMR	32-QFN - Tape and Reel	Extended, -40 to 85 °C
	85 Ω	Si52204-A02BGM	32-QFN	Extended, -40 to 85 °C
		Si52204-A02BGMR	32-QFN - Tape and Reel	Extended, -40 to 85 °C
2-output	100 Ω	Si52202-A01BGM	20-QFN	Extended, -40 to 85 °C
		Si52202-A01BGMR	20-QFN - Tape and Reel	Extended, -40 to 85 °C
	85 Ω	Si52202-A02BGM	20-QFN	Extended, -40 to 85 °C
		Si52202-A02BGMR	20-QFN - Tape and Reel	Extended, -40 to 85 °C

10.1. Technical Support

Table 56. Technical Support URLs

PCIe Clock Jitter Tool	https://www.skyworksinc.com/en/Products/Timing
PCIe Learning Center	https://www.skyworksinc.com/en/application-pages/pci-express-learning-center
Development Kit	https://www.skyworksinc.com/en/products/timing/evaluation-kits/clock/si52204-evaluation-kit

11. Revision History

Revision	Date	Description
B	April, 2026	<ul style="list-style-type: none"> • Added PCIe Gen7 specifications.
A	May, 2023	<ul style="list-style-type: none"> • Based on Revision 1.0 (March, 2019). • Reformatted to new standards. • Added PCIe Gen 6 support. • Updated Table 8, PCIe and Intel QPI Jitter Specifications.

Copyright © 2016-2017, 2019, 2023, 2026, Skyworks Solutions, Inc. All Rights Reserved.

Information in this document is provided in connection with Skyworks Solutions, Inc., and its subsidiaries (“Skyworks”) products or services. These materials, including the information contained herein, are provided by Skyworks as a service to its customers and may be used for informational purposes only by the customer. Skyworks assumes no responsibility for errors or omissions in these materials or the information contained herein. Skyworks may change its documentation, products, services, specifications or product descriptions at any time, without notice. Skyworks makes no commitment to update the materials or information and shall have no responsibility whatsoever for conflicts, incompatibilities, or other difficulties arising from any future changes.

No license, whether express, implied, by estoppel or otherwise, is granted to any intellectual property rights by this document. Skyworks assumes no liability for any materials, products or information provided hereunder, including the sale, distribution, reproduction or use of Skyworks products, information or materials, except as may be provided in Skyworks’ Terms and Conditions of Sale.

THE INFORMATION IN THIS DOCUMENT AND THE MATERIALS AND PRODUCTS DESCRIBED THEREIN ARE PROVIDED “AS IS” WITHOUT WARRANTY OF ANY KIND, WHETHER EXPRESS, IMPLIED, STATUTORY, OR OTHERWISE, INCLUDING FITNESS FOR A PARTICULAR PURPOSE OR USE, MERCHANTABILITY, PERFORMANCE, QUALITY OR NON-INFRINGEMENT OF ANY INTELLECTUAL PROPERTY RIGHT; ALL SUCH WARRANTIES ARE HEREBY EXPRESSLY DISCLAIMED. SKYWORKS DOES NOT WARRANT THE ACCURACY OR COMPLETENESS OF THE INFORMATION, TEXT, GRAPHICS OR OTHER ITEMS CONTAINED WITHIN THESE MATERIALS. SKYWORKS SHALL NOT BE LIABLE FOR ANY DAMAGES, INCLUDING BUT NOT LIMITED TO ANY SPECIAL, INDIRECT, INCIDENTAL, STATUTORY, OR CONSEQUENTIAL DAMAGES, INCLUDING WITHOUT LIMITATION, LOST REVENUES OR LOST PROFITS THAT MAY RESULT FROM THE USE OF THE MATERIALS OR INFORMATION, WHETHER OR NOT THE RECIPIENT OF MATERIALS HAS BEEN ADVISED OF THE POSSIBILITY OF SUCH DAMAGE.

Skyworks products are not designed, intended, authorized, or warranted for use or inclusion in life support or life endangering applications, devices, or systems where failure or inaccuracy might cause death or personal injury. Skyworks customers agree not to use or sell the Skyworks products for such applications, and further agree to, without limitation, fully defend, indemnify, and hold harmless Skyworks and its agents from and against any and all actions, suits, proceedings, costs, expenses, damages, and liabilities including attorneys’ fees arising out of or in connection with such improper use or sale.

Skyworks assumes no liability for applications assistance, customer product design, or damage to any equipment resulting from the use of Skyworks products outside of Skyworks’ published specifications or parameters. Customers are solely responsible for their products and applications using the Skyworks products.

“Skyworks” and the Skyworks Starburst logo are registered trademarks of Skyworks Solutions, Inc., in the United States and other countries. Third-party brands and names are for identification purposes only and are the property of their respective owners. Additional information, including relevant terms and conditions, posted at www.skyworksinc.com, are incorporated by reference.