



USER GUIDE

SKY72302 Frequency Synthesizer Evaluation Board

Copyright © 2001, 2002, 2004, 2005 Skyworks Solutions, Inc. All Rights Reserved.

Information in this document is provided in connection with Skyworks Solutions, Inc. ("Skyworks") products. These materials are provided by Skyworks as a service to its customers and may be used for informational purposes only by the customer. Skyworks assumes no responsibility for errors or omissions in these materials. Skyworks may make changes to its documentation, products, specifications and product descriptions at any time, without notice. Skyworks makes no commitment to update the information and shall have no responsibility whatsoever for conflicts, incompatibilities, or other difficulties arising from future changes to its documentation, products, specifications and product descriptions.

No license, express or implied, by estoppel or otherwise, to any intellectual property rights is granted by or under this document. Except as may be provided in Skyworks Terms and Conditions of Sale for such products, Skyworks assumes no liability whatsoever in association with its documentation, products, specifications and product descriptions.

THESE MATERIALS ARE PROVIDED "AS IS" WITHOUT WARRANTY OF ANY KIND, EITHER EXPRESS OR IMPLIED OR OTHERWISE, RELATING TO SALE AND/OR USE OF SKYWORKS PRODUCTS INCLUDING WARRANTIES RELATING TO FITNESS FOR A PARTICULAR PURPOSE, MERCHANTABILITY, PERFORMANCE, QUALITY OR NON-INFRINGEMENT OF ANY PATENT, COPYRIGHT OR OTHER INTELLECTUAL PROPERTY RIGHT. SKYWORKS FURTHER DOES NOT WARRANT THE ACCURACY OR COMPLETENESS OF THE INFORMATION, TEXT, GRAPHICS OR OTHER ITEMS CONTAINED WITHIN THESE MATERIALS. SKYWORKS SHALL NOT BE LIABLE FOR ANY DAMAGES, INCLUDING SPECIAL, INDIRECT, INCIDENTAL, OR CONSEQUENTIAL DAMAGES, INCLUDING WITHOUT LIMITATION, LOST REVENUES OR LOST PROFITS THAT MAY RESULT FROM THE USE OF THESE MATERIALS WHETHER OR NOT THE RECIPIENT OF MATERIALS HAS BEEN ADVISED OF THE POSSIBILITY OF SUCH DAMAGE.

Skyworks products are not intended for use in medical, lifesaving or life-sustaining applications. Skyworks customers using or selling Skyworks products for use in such applications do so at their own risk and agree to fully indemnify Skyworks for any damages resulting from such improper use or sale.

The following are trademarks of Skyworks Solutions, Inc.: Skyworks®, the Skyworks logo, and Breakthrough Simplicity®. Product names or services listed in this publication are for identification purposes only, and may be trademarks of Skyworks or other third parties. Third-party brands and names are the property of their respective owners. Additional information, posted at www.skyworksinc.com, is incorporated by reference.

Table of Contents

1 Installation and Use 1

1.1 Equipment Requirements 1

1.2 Hardware Setup 1

1.3 SKY72302 Initialization 1

1.4 Crystal Calibration 2

1.5 Set Main and Auxiliary Synthesizer Frequency 3

1.6 Set Main and Auxiliary Synthesizer Sweep Operations 4

1.7 Set Main and Auxiliary Synthesizer Hop Operations 5

2 SKY72302 Custom Hardware Configuration 7

2.1 Power Supply Configurations 7

2.1.1 Power the Main and Auxiliary Charge Pump From a Separate Power Supply or Battery 7

2.1.2 Power the Crystal Oscillator From a Separate Power Supply or Battery 7

2.1.3 Power the Digital Circuitry Section From a Separate Power Supply or Battery 7

2.1.4 Power the Main Synthesizer VCCecl/cml From a Separate Power Supply or Battery 7

2.1.5 Power the Auxiliary Synthesizer VCCecl/cml From a Separate Power Supply or Battery 7

2.2 Reference Source Configurations 7

2.2.1 Change the Reference Oscillator Crystal Frequency 7

2.2.2 Use an On-Board TCVCXO as a Reference Source 8

2.2.3 Use an External Signal Generator or Other Stable 50 Ω Source As a Reference Source 8

2.3 Loop Filter Design 8

2.3.1 Loop Filter Modifications 9

Appendix A

Standard Default SKY72302 Hardware Configuration 11

Nominal VCO Ranges 11

Nominal Crystal Frequency 11

List of Uninstalled Components 11

Circuit Description 11

Main Synthesizer Charge Pump/VCO/Prescaler Loop 11

Auxiliary Synthesizer Charge Pump/VCO/Prescaler Loop 13

Digital Serial Interface 13

Power Supply Pin Connections 13

Reference Oscillator 13

Connector and Jack List 14

Bill of Materials 14

Detailed User Interface Guide 15

Reference Tab 15

Single Tab 17

Sweep Tab 18

Hop Tab 19

Direct M Tab 20

Debug Tab 20

Table of Contents

Figures

- 1. Software Interface Window: Reference Tab2
- 2. Software Interface Window: Single Tab3
- 3. Software Interface Window: Sweep Tab4
- 4. Software Interface Window: Hop Tab5
- 5. Loop Filter, Minimum Hardware9
- 6. Loop Filter, Reduction in Quantization Noise9
- 7. Loop Filter, More Reduction in Quantization Noise10
- 8. SKY72302 Evaluation Board Schematic Diagram12

Tables

- 1 Bill of Materials14

1 Installation and Use

The SKY72302 Evaluation Board enables the system designer to easily evaluate all the performance features of the SKY72302 fractional-N frequency synthesizer. This document provides installation and setup procedures for the Evaluation Board.

See Appendix A of this User Guide for a detailed review of the evaluation software. For details on the SKY72302 device, itself, refer to the Skyworks Data Sheet, *SKY72302 Spur-Free, 6.1 GHz Dual Fractional-N Frequency Synthesizer*, document number 101216.

1.1 Equipment Requirements

- Spectrum analyzer with an optional Phase Noise Analysis feature
- Batteries (preferred) or bench power supply
- One-foot length of insulated hook-up wire
- IBM compatible PC with Windows 98™, Windows 2000™, or Windows NT™
- Parallel printer cable
- Coaxial cable (50 Ω with SMA fittings)
- Female SMA to male BNC adaptor
- Female BNC to male banana adaptor

1.2 Hardware Setup

The SKY72302 Evaluation Board should be powered from battery sources for best noise performance. However, the platform may be operated with bench power supplies if desired.

1. Connect a coaxial cable from J3 to a 3 V source (use an SMA-BNC and BNC-banana adaptor). This powers the SKY72302 synthesizer's analog, digital, and on-board charge pump circuits. The SKY72302 supply voltage is specified to be +2.7 to +3.3 VDC.
2. Connect a +5 VDC supply to JP5 (two pin header with 0.1-inch spacing). Ensure proper polarity (the negative supply lead connected to the terminal nearest to the PCB edge). This powers the VCO for the main synthesizer.
3. Connect a +5 VDC supply to JP6 (two pin header with 0.1-inch spacing). Ensure proper polarity (the negative supply lead connected to the terminal nearest to the VCO module, OSC1). This powers the VCO for the auxiliary synthesizer.
4. Attach a 50 Ω coaxial cable from J1 to the spectrum analyzer.
5. Install a parallel printer cable between the PC's parallel port and the DB25 connector P1. The PC should not be turned on at this time.
6. Power up all supplies.

1.3 SKY72302 Initialization

1. Turn on the PC.
2. Install and run the Windows™-based evaluation software from the CD-ROM supplied by Skyworks.
NOTE: If problems are encountered with the oleaut32.dll file, refer to the readme.txt and fil_update.txt files on the CD-ROM.
3. Click the **Reference** tab of the software interface window (see Figure 1).
4. Click the SKY72302 option button in the upper left corner of the window.
5. Specify "24" MHz for the Xtal Freq.
6. Under Main Reference Settings, click the 18 Bit Fractional-N option button and enter "1" for the Ref Div Value.

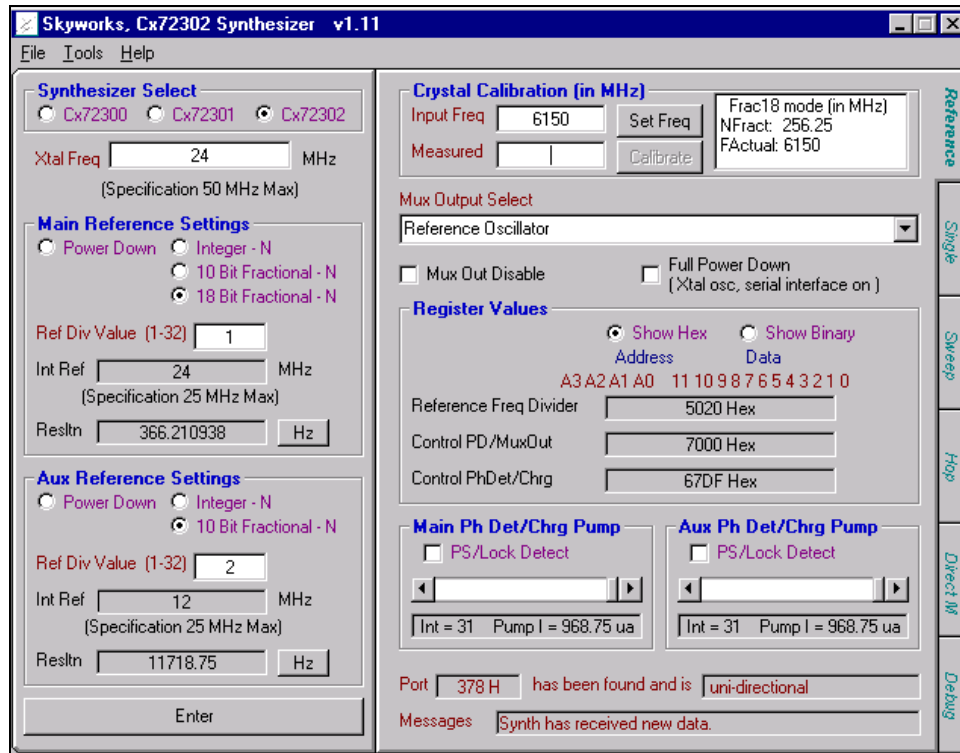

Figure 1. Software Interface Window:Reference Tab

7. Under Aux Reference Settings, click the 10 Bit Fractional-N option button and enter “2” for the Ref Div Value.
8. Click the Enter command button to apply these selections.
9. Ensure that the charge pump current gain is set to maximum by dragging the Main Ph Det/Chrg Pump and Aux Ph Det/Chrg Pump scroll bars all the way to the right.

1.4 Crystal Calibration

This calibration should be performed with the main synthesizer in the 18-bit fractional-N mode. Click on the **Reference** tab of the software interface window and continue below:

1. Under Crystal Calibration (in MHz), enter “6150” in the Input Freq text box and click on the Set Freq button.
2. Locate the locked signal on the spectrum analyzer and adjust the span and resolution bandwidth to read the frequency accurately with the marker. Note that the output frequency is somewhat different than 6150 MHz due to the inaccuracy of the crystal.
3. Enter the actual measured output frequency in the Measured text box and click on the Calibrate button.

The software determines the actual crystal frequency and adjusts the fractional-N divider to place the signal exactly at 6150 MHz. Locate the signal and check its frequency. It should be accurate to within ± 180 Hz.

This is a primary feature of the SKY72302: its ability to offer very small step sizes less than 400 Hz that enable the system to correct for crystal frequency inaccuracy. Such small step sizes cannot be achieved in 10-bit fractional-N or integer-N modes unless the reference frequency is very low.

The corrected crystal frequency is used for both the main and auxiliary synthesizers, and remains valid (assuming the crystal does not drift appreciably) until the Evaluation Board is powered down (a device power down executed by the software does not reset the calibration). It is best to close the application software and then re-open it after each hardware power-up sequence to ensure the board is in a known state before calibrating the crystal.

The calibration sequence is not necessary if the frequency error is acceptable.

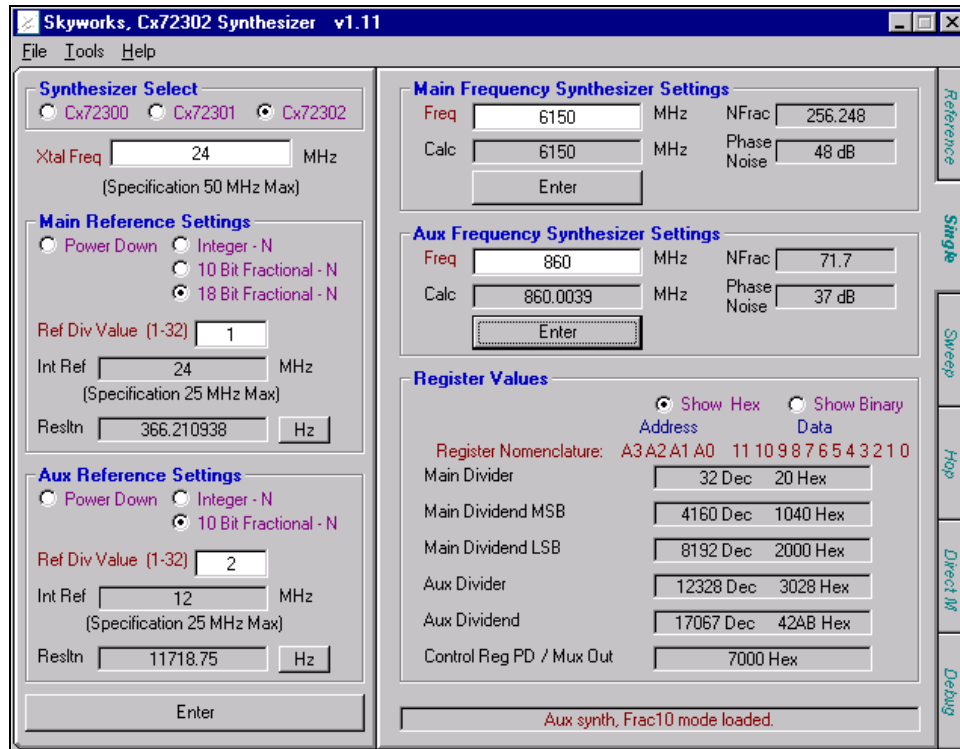

Figure 2. Software Interface Window: Single Tab

1.5 Set Main and Auxiliary Synthesizer Frequency

1. Click the **Single** tab of the software interface window (see Figure 2).
2. Under Main Frequency Synthesizer Settings, enter the desired frequency (in MHz) in the Freq text box.

The main synthesizer VCO frequency shown on the spectrum analyzer should immediately jump to the new frequency (the spectrum analyzer must be connected to the main synthesizer output on the Evaluation Board, the SMA connector J1).

3. Under Aux Frequency Synthesizer Settings, enter the desired frequency (in MHz) in the Freq text box.
4. Click the Enter command button.

The auxiliary synthesizer VCO frequency shown on the spectrum analyzer should immediately jump to the new frequency (the spectrum analyzer must be connected to the auxiliary synthesizer output on the Evaluation Board, the SMA connector J2).

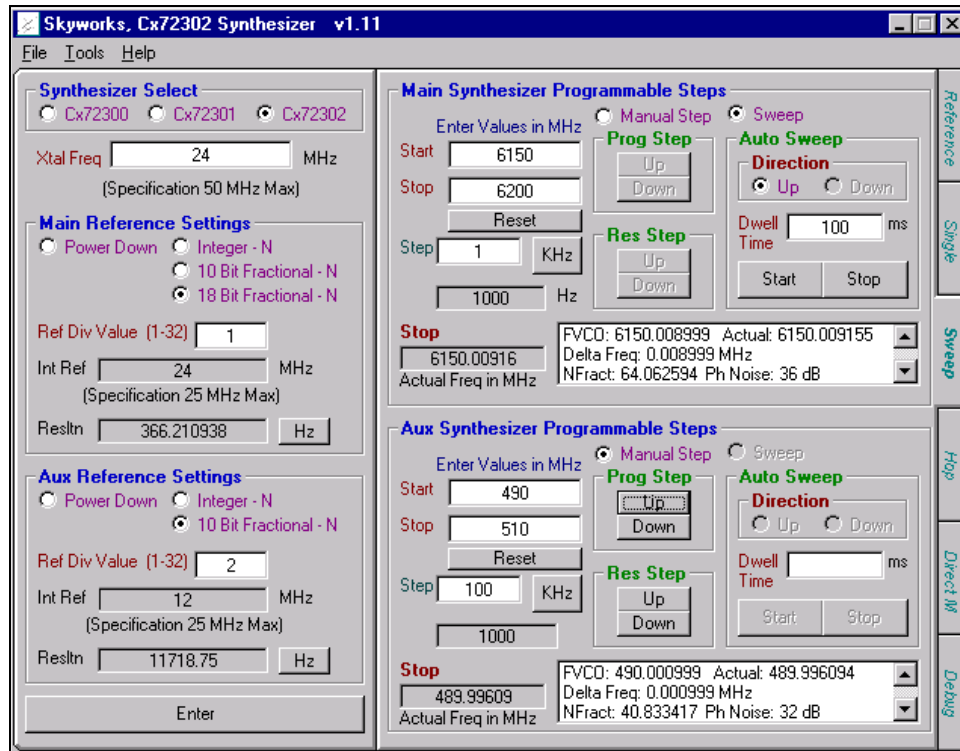

Figure 3. Software Interface Window: Sweep Tab

1.6 Set Main and Auxiliary Synthesizer Sweep Operations

1. Click the **Sweep** tab of the software interface window (see Figure 3).
2. Under Main Synthesizer Programmable Steps, enter the start and stop frequencies in the respective Start and Stop text boxes.
3. Enter the step size (in Hz) in the Step text box.
4. Click on the Start command button and observe the output signal on the spectrum analyzer. The signal steps across the spectrum in the specified step sizes.
5. Under Aux Synthesizer Programmable Steps, enter the start and stop frequencies in the respective Start and Stop text boxes.
6. Enter the step size (in Hz) in the Step text box.
7. Click on the Start command button and observe the output signal on the spectrum analyzer. The signal steps across the spectrum in the specified step sizes.

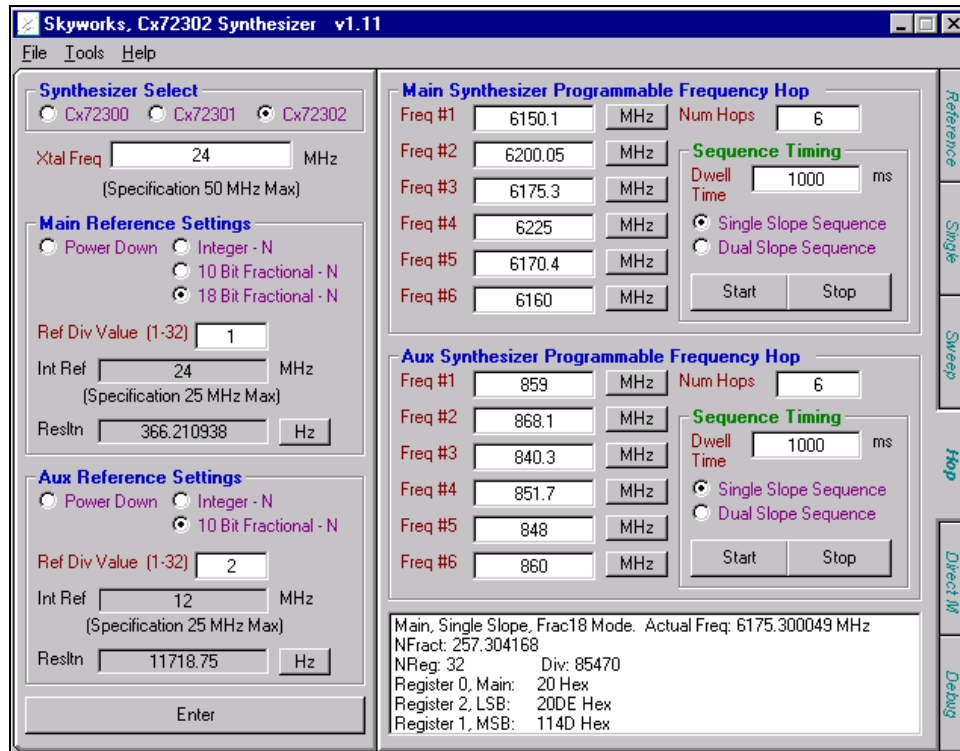

Figure 4. Software Interface Window: Hop Tab

1.7 Set Main and Auxiliary Synthesizer Hop Operations

1. Click the **Hop** tab of the software interface window (see Figure 4).
2. Under Main Synthesizer Programmable Frequency Hop, enter the number of desired hop frequencies in the Num Hops text box.
3. Enter the specific frequencies (in MHz) for each hop frequency desired (maximum of six) in the Freq# text boxes.
4. Under Sequence Timing, enter the the desired dwell time (in ms) in the Dwell Time text box.
5. Click on either the Single Slope Sequence option button or the Dual Slope Sequence option button.
6. Click on the Start command button and observe the output signal on the spectrum analyzer. The main synthesizer signal “frequency hops” in the specified sequence.
7. Under Aux Synthesizer Programmable Frequency Hop, enter the number of desired hop frequencies in the Num Hops text box.
8. Enter the specific frequencies (in MHz) for each hop frequency desired (maximum of six) in the Freq# text boxes.
9. Under Sequence Timing, enter the the desired dwell time (in ms) in the Dwell Time text box.
10. Click on either the Single Slope Sequence option button or the Dual Slope Sequence option button.
11. Click on the Start command button. Click on the Start command button and observe the output signal on the spectrum analyzer. The auxiliary synthesizer signal “frequency hops” in the specified sequence.

This page intentionally left blank

2 SKY72302 Custom Hardware Configuration

This section describes how to modify the Evaluation Board to meet individual requirements. Each procedure below assumes the SKY72302 Evaluation Board to be in the standard default configuration state specified in Appendix A.

2.1 Power Supply Configurations

2.1.1 Power the Main and Auxiliary Charge Pump from a Separate Power Supply or Battery

Dual pin headers with 0.1-inch spacing are installed on the PCB to allow the charge pump to be powered externally (connectors JP3 and JP4).

To power an external main charge pump, remove resistors R68 and R71 and connect the charge pump power supply to connector JP4. For proper polarity, the negative side is connected to the pin closest to the PCB edge.

To power an external auxiliary charge pump, remove resistors R64 and R67 and connect the charge pump power supply to connector JP3. For proper polarity, the negative side is connected to the pin nearest to the center of the PCB.

The maximum charge pump supply voltage is +5 VDC.

2.1.2 Power the Crystal Oscillator from a Separate Power Supply or Battery

1. Remove inductor L3 and attach the positive lead of the crystal oscillator power supply to the pad of L3, which is attached to capacitor C59.
2. Attach the negative lead to the other terminal of C59.

2.1.3 Power the Digital Circuitry Section from a Separate Power Supply or Battery

1. Remove inductor L6 and attach the positive lead of the digital circuitry power supply to the pad of L6, which is attached to capacitor C63.
2. Attach the negative lead to the other terminal of C63.

2.1.4 Power the Main Synthesizer VCCecl/cml from a Separate Power Supply or Battery

1. To apply external Emitter Coupled Logic (ECL) power, remove inductor L10 and attach the positive lead of the power supply or battery to the pad of L10, which is connected to capacitor C68.
2. Attach the negative lead to the other terminal of C68.

2.1.5 Power the Auxiliary Synthesizer VCCecl/cml from a Separate Power Supply or Battery

1. To apply external ECL power, remove inductor L9 and attach the positive lead of the power supply or battery to the pad of L9, which is connected to capacitor C67.
2. Attach the negative lead to the other terminal of C67.

2.2 Reference Source Configurations

2.2.1 Change the Reference Oscillator Crystal Frequency

1. Remove components Y1, C41, and C42.
2. Install a new crystal in place of Y1 (maximum frequency of 50 MHz).
3. Install new loading capacitors, C41 and C42, consistent with the new crystal specifications.

For fundamental suppression of third overtone crystals, two additional component pads (R83, R84 0 Ω links) have been installed in series with the crystal, Y1. Fundamental suppression circuit components should be substituted in place of the 0 Ω links when a third overtone crystal is used.

2.2.2 Use an On-Board TCVCXO as a Reference Source

1. Remove components Y1, C41, and C42.
2. Install a TCVCXO in location U6 (part number TTS05V-19.2 MHz from TEW or equivalent).
3. Install the following resistors:
 - R72 (10 Ω)
 - R62 (47 k Ω)
 - R63 (47 k Ω)
 - R60 (1.5 k Ω)
 - R61 (0 Ω)
 - R57 (0 Ω)
 - 3.9 k Ω resistor in place of capacitor C54
4. Install the following capacitors:
 - C55 (1 nF)
 - C56 (1 μ F)
 - C57 (100 pF)
 - C58 (1 μ F)
 - C52 (.01 μ F)
 - C51 (.01 μ F)
5. Resistors R62 and R63 provide a voltage divider to set the TCVCXO control voltage to half the +3 VDC supply voltage. Change the resistor values so that the divider ratio sets the TCVCXO frequency.
6. Bridge the A1 footprint using a short piece of wire, 26 AWG from pin 1 to pin 3. Alternatively, component A1 (Mini Circuits ERA-3SM) can be installed to provide gain between the TCVCXO and the XTalin/OSC input pin. This option requires the addition of components L2, C43, C44, R49, and modification of attenuator pad components R57, R59, R61.

2.2.3 Use an External Signal Generator or Other Stable 50 Ω Source As a Reference Source

1. Remove components Y1, C41, and C42.
2. Install capacitors C51 (10 nF) and C74 (10 nF).
3. Bridge the A1 footprint using a short piece of wire, 26 AWG from pin 1 to pin 3. Alternatively, component A1 (Mini Circuits ERA-3SM) can be installed to provide gain between the TCVCXO and the XTalin/OSC input pin. This option requires the addition of components L2, C43, C44, and R49.

2.3 Loop Filter Design

Skyworks SKY72302 synthesizer is designed to function with passive components for the loop filter. The synthesizer's integral charge pump eliminates the need for any external active component associated with external charge pump designs.

The Evaluation Board is provided with components to form an adequate loop filter for most evaluation purposes. The main synthesizer has a bandwidth of approximately 80 kHz that yields a good compromise between switching time and noise suppression. The auxiliary synthesizer also has a bandwidth of 80 kHz.

The filter on the Evaluation Board is a second order passive filter with two additional low-pass filter sections to reduce reference feed through and quantization noise. The corner frequency of each of these two sections is set so that the loop's bandwidth is not affected significantly.

2.3.1 Loop Filter Modifications

A convenient procedure has been developed to calculate new values for the loop filter. This method keeps the loop’s natural frequency lower than the Unity Gain Bandwidth (UGBW) by a factor of 1.8.

Figures 5, 6, and 7 illustrate different configurations used to implement loop filters. The standard configuration implemented on the SKY72302 Evaluation Board is shown in Figure 7.

The equations related to each of the three diagrams are used to calculate loop filter component values. The variables used in each of the equations are defined below:

- K_v VCO gain expressed in Hz/V. This parameter is available from the VCO manufacturer’s data sheet.
- f_{ref} Internal reference frequency expressed in Hz. This parameter is dependent on crystal frequency and the software programmable reference divider value.
- I_p Charge pump current expressed in Amperes/ 2π radians. This parameter is dependent on the software programmable charge pump gain register setting.
- $UGBW$ Desired unity gain bandwidth expressed in Hz.
- N_{int} VCO frequency divided by f_{ref} .

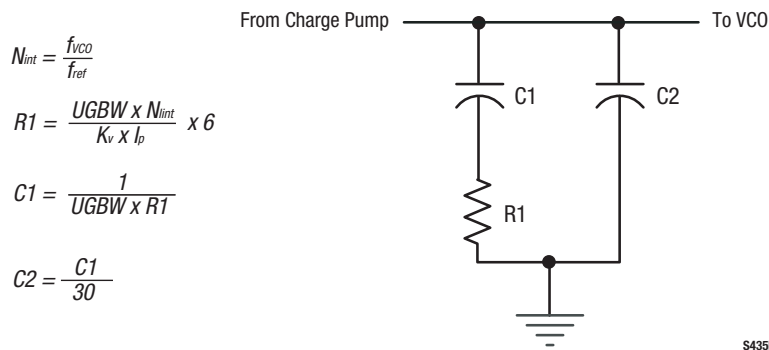

Figure 5. Loop Filter, Minimum Hardware

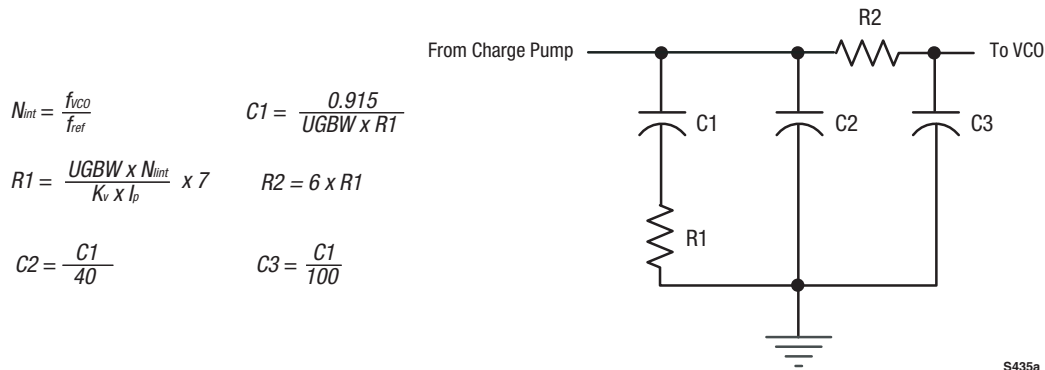

Figure 6. Loop Filter, Reduction in Quantization Noise

$$N_{int} = \frac{f_{VCO}}{f_{ref}}$$

$$R1 = \frac{UGBW \times N_{int}}{K_v \times I_b} \times 4.5$$

$$C2 = \frac{C1}{60}$$

$$R3 = 2.6 \times R1$$

$$C1 = \frac{1.22}{UGBW \times R1}$$

$$R2 = 2.6 \times R1$$

$$C3 = \frac{C1}{45}$$

$$C4 = \frac{C1}{175}$$

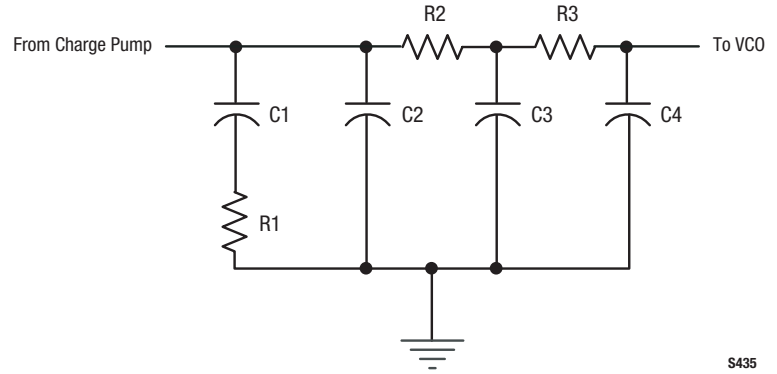

S435

Figure 7. Loop Filter, More Reduction in Quantization Noise

Appendix A

Standard Default SKY72302 Hardware Configuration

Nominal VCO Ranges

- Main VCO (OSC2): 6100 to 6325 MHz
- Auxiliary VCO (OSC1): 835 to 885 MHz

For detailed VCO information, see the manufacturer's Data Sheet (manufacturers are listed in the Bill of Materials section of this Appendix).

Nominal Crystal Frequency

All SKY72302 Evaluation Kits are equipped with a low-cost, 24 MHz crystal (Y1).

List of Uninstalled Components

Since the SKY72302 Evaluation Board can be customized to individual requirements, some components that may be referenced in schematics or bill of materials lists have not been installed as part of the default configuration. These parts are:

- Active devices: A1, U1, U2, U4, U5, U6
- Capacitors: C1, C2, C3, C4, C7, C8, C13, C14, C22, C43, C44, C51, C52, C54, C55, C56, C57, C58, C73, C74
- Inductors: L1, L2
- Resistors: R2, R4, R7, R13, R20, R22, R27, R29, R42, R49, R52, R53, R55, R56, R57, R59, R60, R61, R62, R63, R72
- Connectors: J6

Circuit Description

A schematic diagram of the SKY72302 Evaluation Board is provided in Figure 8.

The core of the Evaluation Board is the Skyworks SKY72302 Fractional-N Frequency Synthesizer, designated part U3. This 28-pin, Exposed Pad Thin Shrink Small Outline Package (EP-TSSOP) contains two independent, high frequency synthesizers. The component schematic symbol has been drawn with main synthesizer pins located on the left hand side of the symbol while the auxiliary synthesizer pins are on the right side.

Main Synthesizer Charge Pump/VCO/Prescaler Loop

The output of the main synthesizer charge pump (pin 11, CPout_main) drives the loop filter (R51, C53, C47, R58, R48, C46, R47, C45, and R46), which controls the main VCO (OSC2) frequency.

OSC2 is powered by a dual-pin header, JP5 (R56 is not installed), with 0.1-inch spacing. The VCO output is fed through a 6 dB attenuator (R39, R36, R26, and R32) to the input of amplifier U5 (uninstalled).

A small jumper wire is installed across pins 3 and 6 of the U5 amplifier's footprint. A Mini-Circuits VNA-25 amplifier can be used in place of the wire to provide further reverse isolation between the VCO and prescaler. When the VNA-25 is installed, the attenuator pad (R39, R36, R26, and R32) should be adjusted so that the drive level into the SKY72302 prescaler is preserved.

Resistors R33, R34, and R24 split the signal into separate paths. One path leading back to the SKY72302 using transformer T2 (M/ACOM 1:1) is the input to the main synthesizer high frequency prescaler (pin 7, Fvco_main, and pin 8, Fvco_main). If desired, the transformer can be removed and a jumper wire installed across pins 3 and 4 of the component T2 footprint to allow unbalanced operation of the prescaler input.

To facilitate this configuration, a bare ground pad has been placed on the PCB next to capacitor C20. During unbalanced operation, the prescaler return path (pin 8, Fvco_main) would be through C20 to the ground pad. Do do this, C20 must be unsoldered and rotated 90 degrees to contact the ground pad.

The other signal path from the splitter feeds another 6 dB attenuator pad (R76, R73, R75, and R74) to amplifier U1 (uninstalled). The default state of the PCB is to have a jumper wire installed across pins 3 and 6 of the U1 pad. If a greater output level is required from SMA jack J1 a Mini-Circuits VNA-25 amplifier can be installed.

With the board default configuration, the main VCO output from J1 is approximately -20 dBm.

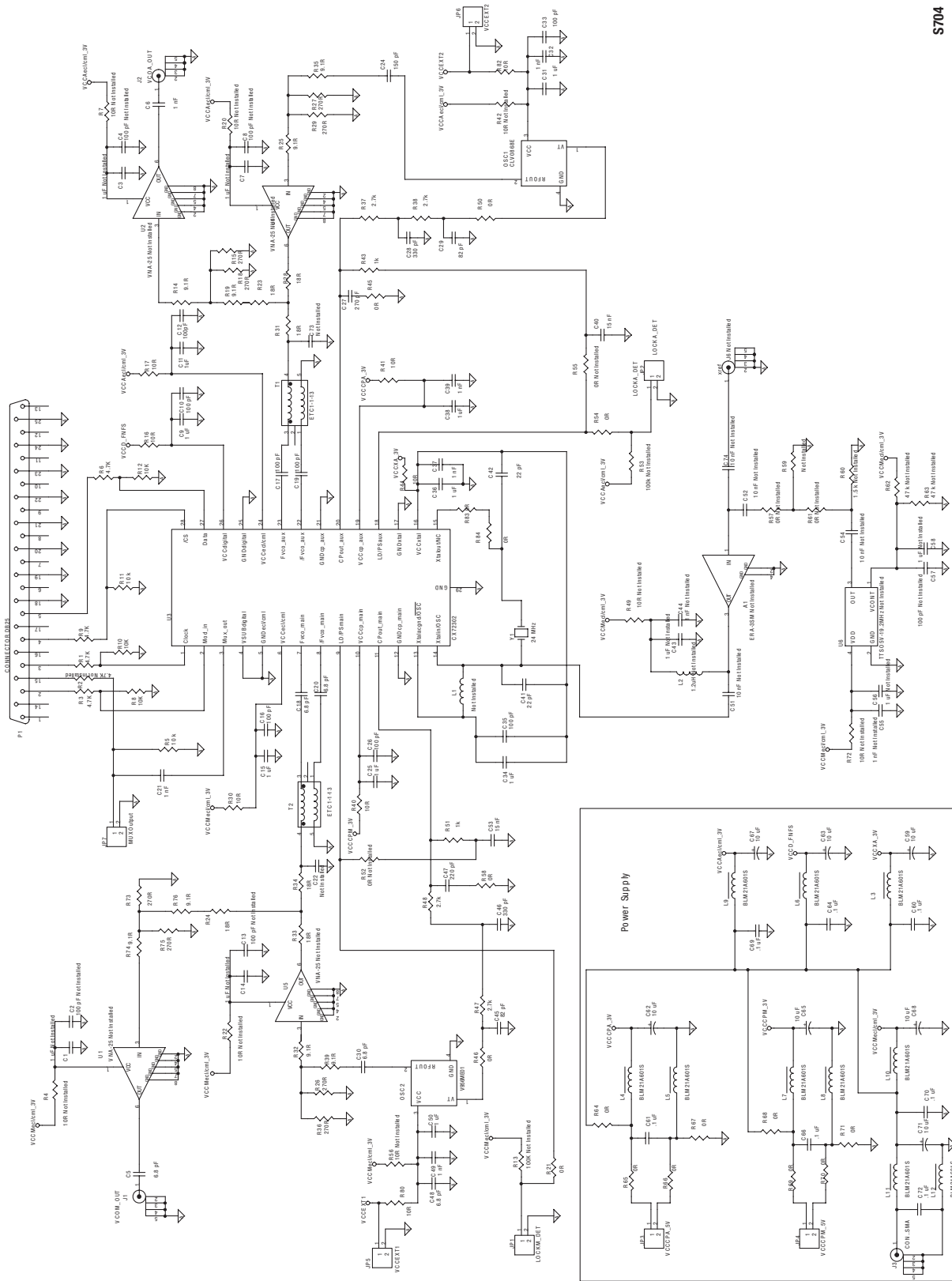

S704

Figure 8. SKY72302 Evaluation Board Schematic Diagram

Auxiliary Synthesizer Charge Pump/VCO/Prescaler Loop

The architecture of the auxiliary synthesizer charge pump/VCO loop is similar to that of the main synthesizer.

The output of the auxiliary synthesizer charge pump (pin 20, CPout_aux) drives the loop filter (C27, R45, R43, C40, R37, C28, R38, C29, and R50). The loop filter output controls the auxiliary VCO (OSC1) frequency.

OSC1 is powered through a dual-pin header, JP6 (R42 is not installed), with 0.1-inch spacing. The OSC1 output is fed through a resistive attenuator pad set for 0 dB attenuation (R35, R27, R29, and R25) to the input of amplifier U4 (uninstalled).

A small jumper is installed across pins 3 and 6 of the U4 amplifier's footprint. A Mini-Circuits VNA-25 amplifier can be used in place of the wire to provide further reverse isolation between the VCO and prescaler. When the VNA-25 is installed, the attenuator pad (R35, R27, R29, and R25) should be adjusted so that the drive level into the prescaler is preserved.

Resistors R28, R23, and R31 split the signal from the auxiliary VCO output into separate paths. One path, leading back to the SKY72302 through transformer T1 (M/ACOM 1:1) is the input to the auxiliary synthesizer high frequency prescaler (pin 22, Fvco_aux, and pin 23, Fvco_aux). If desired, the transformer can be removed and a jumper wire installed across pins 3 and 4 of the component T1 footprint to allow unbalanced operation of the prescaler input.

To facilitate this configuration, a bare ground pad has been placed on the PCB next to capacitor C19. During unbalanced operation, the prescaler return path (pin 22, Fvco_aux) would be through C19 to the ground pad. To do this, C19 must be unsoldered and rotated 90 degrees to contact the ground pad.

The other signal path from the auxiliary VCO output splitter feeds an attenuator pad (R19, R15, R18, and R14) to amplifier U2 (uninstalled). A jumper wire is installed across pins 3 and 6 of the U2 pad. If a greater output level is required from the auxiliary synthesizer output jack, J2, a Mini-Circuits VNA-25 amplifier can be installed.

With the board default configuration, the auxiliary VCO output from J2 is approximately -20 dBm.

Digital Serial Interface

The digital serial interface is comprised of five signals: chip select (pin 28, $\overline{\text{CS}}$), data (pin 27, Data), clock (pin 1, Clock), input (pin 2, Mod_in), and output (pin 3, Mux_out). The PC interface cable is a 25-conductor parallel port cable. Although the SKY72302 synthesizer has a serial microprocessor interface, it is actually operated through the PC's parallel port. Signal lines coming from the PC are passed through simple resistive dividers to lower the voltage from +5 VDC to +3 VDC (it is assumed that the PC controls the parallel port from a +5 VDC source).

Power Supply Pin Connections

The SKY72302 synthesizer has separate power and ground pins for its individual circuit blocks (charge pump, digital interface, crystal oscillator, and prescaler ECL divider logic). To help power these individual circuit blocks from separate power supplies, the SKY72302 Evaluation Board has separate supply lines that can easily be isolated from one another by removing a single supply line component.

An instance in which a different supply voltage might be desirable would be a need to provide a wider VCO tuning range. In this case, a +5 V charge pump supply voltage offers a greater control of voltage swing to the VCO compared to a +3 V supply.

Battery operation is recommended to achieve best spurious output and phase noise performance.

Reference Oscillator

The SKY72302 Evaluation Board has been fitted with several reference frequency signal source options. The default configuration uses a piezoelectric crystal with loading capacitors (Y1, C41, and C42). Other options include using an external signal generator to drive the Xtalin/OSC pin of the SKY72302 using SMA J6 (uninstalled), or using a TCVCXO module at location U6 (uninstalled).

Provision is also made for a balanced oscillator input drive (at pins 13 and 14). Components L1 (uninstalled), C34, C35, and C41 need to be modified to achieve balanced drive configuration.

Oscillator AC ground is assumed to be handled by the VCCxtal signal (pin 16). Therefore, Xtalacgnd/ $\overline{\text{OSC}}$ (pin 13) is coupled to the VCCxtal rail using capacitors C34 and C35.

If a third overtone crystal is installed at Y1, suppression of the fundamental may be necessary. To facilitate this, additional components have been installed in series with the crystal. These components (R83 and R84, both 0 Ω links) are intended to be replaced with suppression circuit components when a third overtone crystal is used.

Connector and Jack List

- J1 SMA: main synthesizer VCO output (through attenuation pad)
- J2 SMA: auxiliary synthesizer VCO output (through attenuation pad)
- J3 SMA: +2.7 to +3.3 VDC supply voltage for SKY72302 device powering
- J6 SMA: external reference signal source input (J6 not installed)
- JP1 dual-pin, 0.1-inch spacing header: main synthesizer lock detect output
- JP2 dual-pin, 0.1-inch spacing header: auxiliary synthesizer lock detect output
- JP3 dual-pin, 0.1-inch spacing header: auxiliary synthesizer charge pump external VCC supply
- JP4 dual-pin, 0.1-inch spacing header: main synthesizer charge pump external VCC supply
- JP5 dual-pin, 0.1-inch spacing header: main synthesizer VCO (OSC2) external VCC supply
- JP6 dual-pin, 0.1-inch spacing header: auxiliary synthesizer VCO (OSC1) external VCC supply
- JP7 dual-pin, 0.1-inch spacing header: Mux_out pin of SKY72302
- P1 DB-25 male: synthesizer serial programming interface for connection to IBM-compatible PCs

Bill of Materials

Table 1 provides a list of all the parts that comprise the SKY72302 Evaluation Board.

Table 1. Bill of Materials (1 of 2)

Item	Qty	Part Reference Designator	Part Number/Value	Mfr
1	1	A1 – Not Installed	ERA-3SM	Mini-Circuits
2	5	C5, C18, C20, C30, C48	6.8 pF	
3	2	C41, C42	22 pF	
4	2	C29, C45	82 pF	
5	8	C10, C12, C16, C17, C19, C26, C33, C35	100 pF	
6	5	C2, C4, C8, C13, C57 – Not Installed	100 pF DNI	
7	1	C24	150 pF	
8	1	C47	220 pF	
9	1	C27	270 pF	
10	2	C28, C46	330 pF	
11	6	C6, C21, C32, C37, C39, C49	1 nF	
12	2	C44, C55 – Not Installed	1 nF DNI	
13	4	C51, C52, C54, C74 – Not Installed	10 nF DNI	
14	2	C40, C53	15 nF	
15	7	C60, C61, C64, C66, C69, C70, C72	0.1 μF	
16	9	C9, C11, C15, C25, C31, C34, C36, C38, C50	1 μF	
17	7	C1, C3, C7, C14, C43, C56, C58 – Not Installed	1 μF DNI	
18	7	C59, C62, C63, C65, C67, C68, C71	10 μF	
19	2	C22, C73 – Not Installed	DNI	
20	1	J1	VCOM_OUT	
21	1	J2	VCOA_OUT	
22	1	J3	CON..SMA	
23	1	J6 – Not Installed	Ext Ref DNI	
24	1	L1 – Not Installed	Inductor DNI	

Table 1. Bill of Materials (2 of 2)

Item	Qty	Part Reference Designator	Part Number/Value	Mfr
25	1	L2 – Not Installed	1.2 μ H DNI	
26	10	L3, L4, L5, L6, L7, L8, L9, L10, L11, L12	BLM21A601S	Murata-Erie
27	1	OSC1	CLV0868E	Z-Comm
28	1	OSC2	V956ME01	Z-Comm
29	1	P1	Connector DB25	
30	16	R21, R45, R46, R50, R54, R58, R64, R65, R66, R67, R68, R69, R70, R71, R83, R84	0 Ω	
31	4	R52, R55, R57, R61 – Not Installed	0 Ω DNI	
32	8	R14, R19, R25, R32, R35, R39, R74, R76	9.1 Ω	
33	8	R16, R17, R30, R40, R41, R44, R80, R82	10 Ω	
34	8	R4, R7, R20, R22, R42, R49, R56, R72 – Not Installed	10 Ω DNI	
35	6	R23, R24, R28, R31, R33, R34	18 Ω	
36	8	R15, R18, R26, R27, R29, R36, R73, R75	270 Ω	
37	2	R43, R51	1 k Ω	
38	1	R60 – Not Installed	1.5 k Ω DNI	
39	2	R47, R48	2.7 k Ω	
40	2	R37, R38	2.7 k Ω	
41	4	R1, R3, R6, R9	4.7 k Ω	
42	1	R2 – Not Installed	4.7 k Ω DNI	
43	5	R5, R8, R10, R11, R12	10 k Ω	
44	2	R62, R63 – Not Installed	47 k Ω DNI	
45	2	R13, R53 – Not Installed	100 k Ω DNI	
46	1	R59 – Not Installed	DNI	
47	2	T2, T2	ETC1-1-13	M/A-COM
48	4	U1, U2, U4, U5 – Not Installed	VNA-25	Mini-Circuits
49	1	U3	SKY72302	Skyworks
50	1	U6 – Not Installed	TTS05V, 19.2 MHz	TEW
51	1	Y1	ECS-240-20-4-B, 24 MHz	ECS, Inc.

Detailed User Interface Guide

The Evaluation Board for the SKY7230x family of frequency synthesizers is configured through Skyworks evaluation software. The software interface is a single dialog window with several tabs that represent different sets of configuration functions. This section describes each of the main dialog areas of the software interface window.

Reference Tab

Synthesizer Select. The available devices that can be selected are:

- SKY72300 2.1 GHz dual fractional-N frequency synthesizer
- SKY72301 1.0 GHz dual fractional-N frequency synthesizer
- SKY72302 6.1 GHz dual fractional-N frequency synthesizer

Xtal Freq. A maximum frequency of 50 MHz is entered here.

Main and Aux Reference Settings. Operating mode options include:

- Power down
- Integer-N mode
- 10-bit Fractional-N mode
- 18-bit Fractional-N mode (available for the main synthesizer only)

Ref Div Value. The desired reference divider value in the range of 1 to 32. The main and auxiliary reference divider values are independent and do not have to be the same.

Int Ref. The maximum value for the internal references is 25 MHz.

Resltn. The synthesizer resolution value or step size. Click the Hz button to toggle value displayed from Hz to kHz to MHz.

When all of the necessary synthesizer information has been entered, click the Enter command button at the bottom of the screen. This initializes the synthesizer with the above settings and must be clicked after any changes are made to this area of the software.

The right side of the **Reference Tab** window is used to calibrate the synthesizer output with variations in the crystal oscillator frequency. This method ensures that any changes in the crystal reference frequency can be easily corrected at the output of the PLL.

Input Freq. When the input frequency is entered, and the Set Freq command button clicked, the 18-bit fractional mode, the fractional-N value, and the calculated output frequency are displayed in the status box on the right.

The main synthesizer should be in 18-bit fractional-N mode for this calibration to be effective. Measure the output of the main synthesizer with a spectrum analyzer or frequency counter.

Measured. The measured synthesizer output frequency value in MHz. When the Calibrate command button is clicked, the 18-bit fractional mode, the change in the crystal oscillator frequency in ppm, and the new fractional-N value are updated in the status box on the right.

The synthesizer calculates the N value used to tune the output frequency to the value entered in the Input Freq text box. The software uses the calculated N value to divide the frequency that was entered in the Measured text box. The result must be the actual internal reference frequency.

When this value is multiplied by the reference divider value, the result is the actual operating output frequency of the crystal oscillator. The software automatically enters the newly calculated crystal oscillator value into the Xtal Frequency input box and updates the Int Ref and Resltn values.

This calibration method can be used in final production to calibrate the radio output without any mechanical “tweaking.” This method compensates for the initial absolute frequency error of the crystal, and can be used in the field to compensate for temperature drift and aging in the crystal without needing to know the actual temperature.

Mux Output Select. The drop-down list provides the available choices for the desired output on pin 3 (Mux_out) of the synthesizer:

- Reference Oscillator
- Auxiliary Reference Oscillator
- Main Reference Oscillator
- Auxiliary Phase Detector Frequency
- Main Phase Detector Frequency
- Serial Data Out
- Serial Interface Test Output
- Modulator Test Output

Mux Out Disable. Select this check box to disable the Mux-out pin of the synthesizer, placing it in a high impedance state.

Full Power Down. Select this check box to leave only the crystal oscillator and serial interface powered up.

Register Values. Select the Show Hex or Show Binary option button to view register information in either hexadecimal or binary, respectively.

The registers shown are those that are affected by any changes on the viewable screen. They are:

- Reference Freq Divider
- Control PD/MuxOut
- Control PhDet/Chrg

Main and Aux Ph Det/Chrg Pump. The PS/Lock Detect check box is used to place the main and/or auxiliary synthesizer in power steering (sped up) mode. When checked, PS/Lock Detect changes to Power Steering/LD on the screen. When not checked, the respective synthesizer is in lock detect mode and the display reads PS/Lock Detect.

The two slide bars control the charge pump current outputs for both the main and auxiliary synthesizers, each independently controlled. The charge pump current values are displayed in the status boxes below each slide bar. The integer register values are also displayed. The values range from 4 to 31, which corresponds to charge pump currents of 125 to 968.75 μ A, respectively.

Single Tab

Synthesizer Select. The available devices that can be selected are:

- SKY72300 2.1 GHz dual fractional-N frequency synthesizer
- SKY72301 1.0 GHz dual fractional-N frequency synthesizer
- SKY72302 6.1 GHz dual fractional-N frequency synthesizer

Xtal Freq. A maximum frequency of 50 MHz is entered here.

Main and Aux Reference Settings. Operating mode options include:

- Power down
- Integer-N mode
- 10-bit Fractional-N mode
- 18-bit Fractional-N mode (available for the main synthesizer only)

Ref Div Value. The desired reference divider value in the range of 1 to 32. The main and auxiliary reference divider values are independent and do not have to be the same.

Int Ref. The maximum value for the internal references is 25 MHz.

Resltn. The synthesizer resolution value or step size. Click the Hz button to toggle the value displayed from Hz to kHz to MHz.

When all of the necessary synthesizer information has been entered, click the Enter command button at the bottom of the screen. This initializes the synthesizer with the above settings and must be clicked after any changes are made to this area of the software.

The right side of the **Single Tab** window is used to set the desired frequencies for the main and auxiliary synthesizers.

Main and Aux Frequency Synthesizer Settings. The desired synthesizer output frequency is entered in the Freq text box for either the main or auxiliary synthesizers. When the Enter command button is clicked, the synthesizer output is set to the desired frequency.

The Calc display box shows the actual output frequency (in MHz) of the synthesizer since it may not be able to tune exactly to the desired frequency. This value is based on the resolution of the synthesizer and is dependent on the mode of operation.

The NFrac display box indicates the multiplication N value between the current frequency output and the internal reference frequency.

The Phase Noise display box indicates the calculated additional contribution of the current multiplication N value. This value can be used to quickly determine the additional contribution to the total phase noise due to the multiplied value.

Register Values. Select the Show Hex or Show Binary option button to view register information in either hexadecimal or binary, respectively.

The registers shown are those that are affected by any changes on the viewable screen. They are:

- Main Divider
- Main Dividend MSB
- Main Dividend LSB
- Aux Divider
- Aux Dividend
- Control Reg PD/Mux Out

Sweep Tab

Synthesizer Select. The available devices that can be selected are:

- SKY72300 2.1 GHz dual fractional-N frequency synthesizer
- SKY72301 1.0 GHz dual fractional-N frequency synthesizer
- SKY72302 6.1 GHz dual fractional-N frequency synthesizer

Xtal Freq. A maximum frequency of 50 MHz is entered here.

Main and Aux Reference Settings. Operating mode options include:

- Power down
- Integer-N mode
- 10-bit Fractional-N mode
- 18-bit Fractional-N mode (available for the main synthesizer only)

Ref Div Value. The desired reference divider value in the range of 1 to 32. The main and auxiliary reference divider values are independent and do not have to be the same.

Int Ref. The maximum value for the internal references is 25 MHz.

Resltn. The synthesizer resolution value or step size. Click the Hz button to toggle value displayed from Hz to kHz to MHz.

When all of the necessary synthesizer information has been entered, click the Enter command button at the bottom of the screen. This initializes the synthesizer with the above settings and must be clicked after any changes are made to this area of the software.

The right side of the **Sweep Tab** window is used to set the desired sweep frequencies for the main and auxiliary synthesizers.

Main and Aux Synthesizer Programmable Steps. The desired upper and lower frequency limits are entered into the Start and Stop text boxes (in MHz) for either the main or auxiliary synthesizer.

During any operation, click the Reset button to return the current synthesizer status to its original setting.

Manual Step. The two Prog Step up/down command buttons and the two Res Step up/down command buttons are activated when the Manual Step option button has been selected.

Prog Step. Click the Up or Down command buttons to manually adjust the current synthesizer frequency by one value in the programmed Step box. These two command buttons are activated when the Manual Step option button has been selected.

Click the Reset button to return the start value to its original setting.

Res Step. Click the Up or Down command buttons to adjust the current synthesizer frequency by one value in the Resltn step size box.

Click the Reset button to return the start value to its original setting.

These functions can be performed in conjunction with the programmed step size to help troubleshoot a perceived frequency problem without having to reprogram the step size.

Sweep. The Auto Sweep option buttons, Dwell Time text box, and Start/Stop command buttons are activated when the Sweep option button has been selected.

Direction. The Up/Down option buttons “sweep” the current synthesizer frequency higher or lower by the value shown in the Step text box.

Dwell Time. This text box is used to enter the desired time between frequency increments. The dwell time value must be entered in milliseconds and ranges from 50 to 1000 ms.

Click the Start button to commence the sweep at its current frequency.

Click the Stop button to halt the sweep at its current frequency.

Click the Reset button to return the start value to its original setting.

Step. This text box is used to enter the desired step size (in kHz). Click the Hz button to toggle the value displayed from Hz to kHz to MHz.

The display box below the Step text box indicates the starting value to be output by the synthesizer in either sweep or manual modes. To display the Stop frequency of the main synthesizer, place the cursor in the Stop text box (similarly, place the cursor in the Start text box at the bottom of the window to display the auxiliary synthesizer start frequency).

The large display box with the scroll bar to the right of the Stop display box indicates the current settings for the following:

- FVCO. This is the desired output frequency of the synthesizer (in MHz) based on the programmed step size.
- Actual. This value is the calculated output frequency of the synthesizer (in MHz) based on the available step size.
- Delta Freq. This number represents the current frequency offset (in MHz) from the original starting frequency.
- NFract. This is the current multiplication N value between the current output frequency and the internal reference frequency.
- Ph Noise, which indicates the calculated additional contribution of current multiplication N value.
- Register information, which indicates the values in any of the registers that are affected in this mode.

Hop Tab

Synthesizer Select. The available devices that can be selected are:

- SKY72300 2.1 GHz dual fractional-N frequency synthesizer
- SKY72301 1.0 GHz dual fractional-N frequency synthesizer
- SKY72302 6.1 GHz dual fractional-N frequency synthesizer

Xtal Freq. A maximum frequency of 50 MHz is entered here.

Main and Aux Reference Settings. Operating mode options include:

- Power down
- Integer-N mode
- 10-bit Fractional-N mode
- 18-bit Fractional-N mode (available for the main synthesizer only)

Ref Div Value. The desired reference divider value in the range of 1 to 32. The main and auxiliary reference divider values are independent and do not have to be the same.

Int Ref. The maximum value for the internal references is 25 MHz.

Resltn. The synthesizer resolution value or step size. Click the Hz button to toggle value displayed from Hz to kHz to MHz.

When all of the necessary synthesizer information has been entered, click the Enter command button at the bottom of the screen. This initializes the synthesizer with the above settings and must be clicked after any changes are made to this area of the software.

The right side of the **Hop Tab** window is used to set the desired hop frequencies for the main and auxiliary synthesizers.

Main and Aux Synthesizer Programmable Frequency Hop. Up to six individual output frequencies (in MHz) can be entered into the Freq #1 through Freq #6 text boxes. The main and auxiliary synthesizers can both perform hopping at the same time. Click the MHz button for each frequency to toggle the value displayed from Hz to kHz to MHz.

Num Hops. This text box is used to enter the desired total number of discreet frequencies (1 to 6). Note that the number entered here directs how many of the Freq #1-6 text boxes are available.

Sequence Timing. This text box is used to enter the desired time between frequency hops. The dwell time value must be entered in milliseconds and ranges from 50 to 1000 ms.

Single Slope Sequence. This option button is selected for a hopping sequence from 1 through 6 that returns to 1 through 6, repetitively.

Dual Slope Sequence. This option button is selected for a sequence from 1 through 6 that reverses the direction from 6 through 1, repetitively.

Hopping frequencies are not limited to being sequential. Random frequencies can be selected if desired.

Click the Start button to begin the hop from its current frequency.

Click the Stop button to halt the hop at its current frequency.

The large text display box at the bottom of the window indicates the current settings for each of the following:

- Main or Auxiliary synthesizer currently operating
- Single or Dual Slope
- Fractional-N or Integer-N mode
- Actual Freq (the calculated output frequency of the synthesizer based on the available step size)
- NFract (the current multiplication N value between the current output frequency and the internal reference frequency)
- Register information. This includes the values in any of the registers that are affected in this mode

Direct M Tab

The Direct Modulation function is not available with this version of the evaluation software.

Debug Tab

The **Debug** tab is reserved for internal Skyworks engineering use.